

Safety Light Grid**AREAL**
LIGHT GRID**Fitting and
Operating
Instructions**

Edition: 11-96/1
Order No.: 600953

About the Fitting and Operation Manual

LUMIFLEX points out to its customers that the information and remarks given in this manual may be subject to change, particularly based on further development of LUMIFLEX products.

This manual does not contain any guarantee of LUMIFLEX concerning described technical procedures or particular product properties. LUMIFLEX does not take any liability for typographical errors or other inaccuracies, except of those evidently known and not corrected by LUMIFLEX or, based on grossly negligent, unknown to LUMIFLEX.

LUMIFLEX points out distinctly to its customers that the information given in this manual describes application related technical procedures. Not in each single event the realization of those procedures may be significant. In case of doubt, please contact LUMIFLEX.

Liability expulsion in case of inappropriate use

LUMIFLEX is not liable for damages, caused by improper use of the equipment. Knowledge of this instruction manual is fundamental for appropriate utilization. Therefore, it is advisable to follow the instructions of this manual as well as the technical documents of any of the connected switching devices, sensors or safety related PLC's accurately. In order to avoid personal injury, the safety instructions comprised in this manual must be followed. Liability is excluded for failures caused by nonobservance of the fitting and operating instructions.



Remark



Caution,
Safety instruction

Reprint and copying

LUMIFLEX as the copyright holder reserves all rights for duplicating this manual. Without written approval issued from LUMIFLEX neither duplicating this manual, respectively parts of it, nor translations into other languages are permitted.

© Reprint and copying, including excerpts of it, only with distinct approval by
LUMIFLEX Elektronik GmbH & Co. KG
Ehrenbreitsteiner Straße 44
D-80993 München

Table of contents

1	AREAL Safety Light Grid	1 - 1
1.1	Field of applications	1 - 2
1.2	Application requirements	1 - 3
1.3	Components of AREAL Safety Light Grids	1 - 3
1.3.1	Transmitter	1 - 3
1.3.2	Receiver	1 - 3
1.3.3	"Start/Restart" push-button	1 - 4
1.3.4	Indication elements	1 - 4
2	Scope of supply	2 - 1
2.1	AREAL Safety Light Grid	2 - 1
2.2	Accessories	2 - 2
2.2.1	Mounting sets	2 - 2
2.2.2	AC power supply unit A-PSU and relay unit A-RU	2 - 5
2.2.3	Column with deflecting mirror	2 - 5
2.2.4	Laser alignment aid	2 - 6
2.2.5	Akkalit protecting screen	2 - 6
2.3	Servicing	2 - 6
3	General safety instructions	3 - 1
3.1	Intended use	3 - 1
3.2	Application regulations	3 - 1
3.3	Considered standards	3 - 2
3.4	Shipping instructions	3 - 3
4	Function	4 - 1
4.1	Operating modes	4 - 1
4.1.1	Without internal restart interlock, without external relays monitoring	4 - 1
4.1.2	With internal restart interlock, with external relays monitoring	4 - 1
4.1.3	Setting the operating modes	4 - 2
4.2	External relays monitoring	4 - 2

5	Fitting	5 - 1
5.1	Fitting regulations	5 - 1
5.1.1	Minimum distances of perimeter guarding (vertical positioning)	5 - 1
5.1.2	Minimum distances of area guarding (horizontal positioning)	5 - 2
5.1.3	Distance towards reflective surfaces	5 - 3
5.1.4	Mounting position	5 - 4
5.1.5	Avoidance of mutual interference	5 - 4
5.2	Mounting set, wall without angle plate	5 - 5
5.3	Mounting set, wall with angle-plate	5 - 8
5.4	Mounting set, floor/column	5 - 9
5.5	Aligning transmitter and receiver	5 - 11
5.6	Laser alignment aid	5 - 11
6	Electrical connections	6 - 1
6.1	Transmitter	6 - 2
6.2	Receiver	6 - 2
7	Initial operation	7 - 1
7.1	Operating mode "Without restart interlock, without external relays monitoring"	7 - 1
7.2	Operating mode "With restart interlock, with external relays monitoring"	7 - 2
8	Technical Data for AREAL and AREAL-M	8 - 1
8.1	Common technical data for transmitter and receiver	8 - 1
8.2	Transmitter	8 - 1
8.3	Receiver	8 - 2
8.4	AC power supply unit A-PSU and relay unit A-RU	8 - 3
8.5	Control devices	8 - 4
8.6	Dimensional drawings	8 - 5

9	Diagnostics, troubleshooting - AREAL and AREAL-M	9 - 1
9.1	Transmitter	9 - 1
9.1.1	Replacing the transmitter fuse	9 - 2
9.1.2	Replacing a transmitter optic module	9 - 2
9.2	Receiver	9 - 3
9.2.1	Replacing the receiver fuse	9 - 7
9.2.2	Replacing a receiver optic module	9 - 7
9.3	Maintenance	9 - 7
10	AREAL-M Safety Light Grid with "Muting"	10 - 1
10.1	Muting	10 - 1
10.2	Muting sensors	10 - 2
10.3	Control and indication elements	10 - 2
10.4	Nomenclature	10 - 3
10.5	Operating modes	10 - 3
10.5.1	Sequential mode	10 - 4
10.5.2	Parallel mode	10 - 6
10.5.3	10-minutes muting time monitoring	10 - 8
10.6	Setting up muting with a transport system located in the muting area	10 - 10
10.7	Additional test facility for muting sensors by an external signal	10 - 10

1 AREAL Safety Light Grid

The AREAL Safety Light Grid is a self monitoring **Active Opto-electronic Protective Device** (Type 4 AOPD) according to the requirements of pr EN 50100 part 1 and part 2.

The AREAL Safety Light Grid consists of:

- Transmitter (AT = AREAL Transmitter)
 - Receiver (AR = AREAL Receiver)
 - Connecting sockets for sender and receiver
 - Mounting set
-
- Accessories, like wall mounting sets with or without angle-plate, columns, deflecting mirrors, alignment aid, AC power supply or relay unit.



Remark: The Light Grid is also available as type AREAL-M with an integrated muting function. Thus, AREAL-M is able to distinguish between persons and material entering the sensing field. To avoid hazardous situations, the safety instructions described in Chapter 10 must be followed.

Construction and function

The transmitter of the AREAL Safety Light Grid transmits several light beams to the receiver. In case of interrupting one or more of these light beams, a switching output signal is generated to stop the dangerous movement. The restart occurs via a manually operated control device.

Perimeter guarding and danger area guarding

For vertical perimeter guarding of danger areas, 2, 3, or 4 beam models are available. For use as horizontal area guarding there are models with up to 122 beams and different pitches to meet the requirements of pr EN 999.

1.1 Field of applications

Perimeter guarding

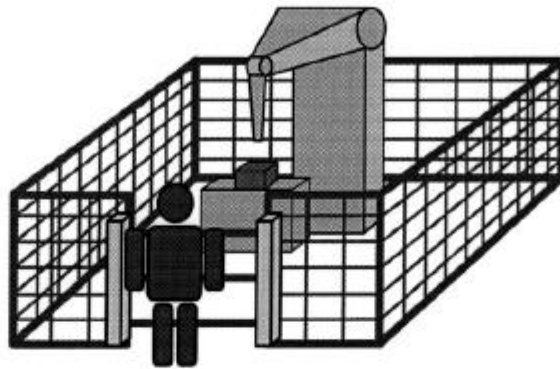

Danger area guarding

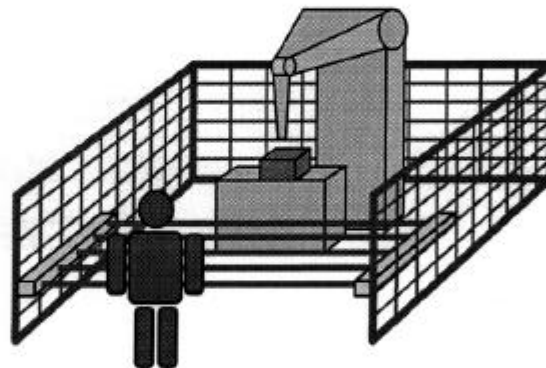

Perimeter guarding on all sides

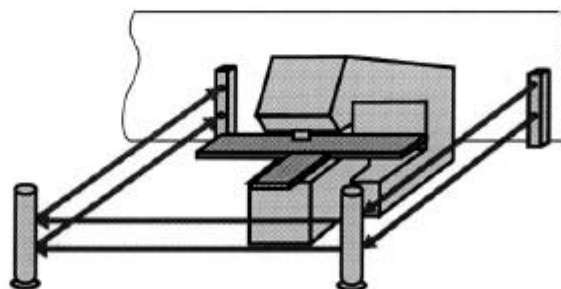

1.2 Application requirements

AREAL Safety Light Grids provide protection only if the following conditions are fulfilled:

- The machine control must allow for an immediate stop of the dangerous movement in each phase of the machine cycle.
- Electrical signals must have influence to the machine control.
- All requirements of the fitting and operating instructions must be fulfilled.



Warning: It serves for perimeter guarding or for area guarding, depending on the application. Its sensing capacity is laid out to detect persons. **It must not be used for hand or finger protection.**

1.3 Components of AREAL Safety Light Grids

1.3.1 Transmitter

The transmitter consists of a solid housing. Depending on the application, 2 up to 122 transmitter inserts are imbedded. The transmitter needs only power supply voltage (24 V DC) via the provided connector type HAN 15 D (Harting) according to DIN 43652.

1.3.2 Receiver

The receiver includes the complete evaluation unit and the switching outputs.

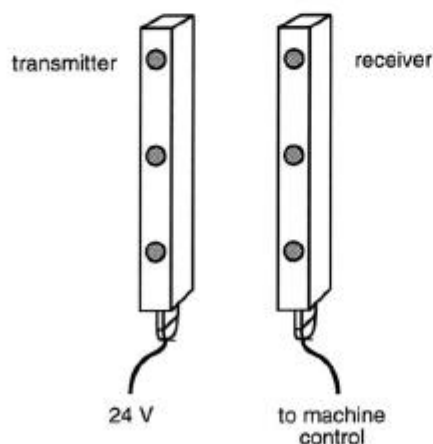

1.3.3 "Start/Restart" push-button

A push-button "Start/Restart" serves as a control device for resetting the "restart interlock." This button is not part of the scope of delivery.

The button must have one normally open and one normally closed contact. It is connected to the AREAL receiver, pin B4, C5 and A3 (for more details see Chapter 6, Electrical connections).



Warning: The control elements must be positioned in a way, which makes their controlling from inside the danger zone impossible. From the selected position, a person must be able to overlook the complete danger zone.

Pushing the "Start/Restart" button for more than 4 seconds leads to a blinking sequence of the yellow LEDs of the AREAL receiver inserts (for more details see Chapter 9, Diagnostics, troubleshooting).

1.3.4 Indication elements

Transmitter

Each transmitter insert contains a yellow LED.

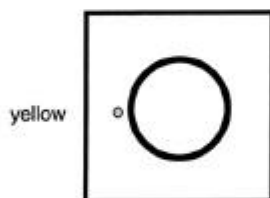

With its on-state it indicates that power is provided and sufficient pulsed current is flowing through the associated sender diode.

Receiver

Each receiver insert contains 3 different coloured LEDs.

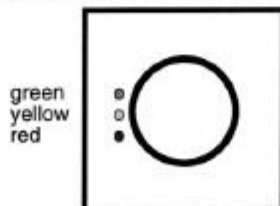

The red and green LEDs show the switching state of the fail-safe pnp semiconductor outputs (OSSDs). Green means the switching outputs are in ON-state (+ 24 V), red means the switching outputs are in OFF-state (0 V). The yellow LED serves as an indicator for the amount of light received and, additionally, shows system states and error messages (see Chapter 9, Diagnostics, troubleshooting).



Indication outputs

Warning: The indication outputs must not be used for any safety related signal processing.

The receiver interface offers two short-circuit resistant pnp semiconductor indication outputs. These outputs may be connected either to a PLC or to a visual display unit.

The indication output C3 serves for indication of the switching output status only. Interrupting the sensing field, respectively switching the OSSD to the OFF-state, leads to + 24 V at C3.

The meaning of the indication output B5 is selectable by an internal DIP-switch. It either serves as an indicator for the sensing field status (0 V = all light beams free, + 24 V = light beams not free) or as an error indicator (0 V = no error, + 24 V = error). The maximum current carrying capacity is 50 mA each.

The following table shows the setting of the DIP-switches. To adjust the DIP-switches, open the receiver bottom cover (with plug connector) and pull out the printed board about 20 mm.

Meaning	S1	S2	S3	Preadjusted
Indication output B5 "Error message"	OFF	---	---	yes
Indication output B5 "Sensing field interrupted"	ON	---	---	no

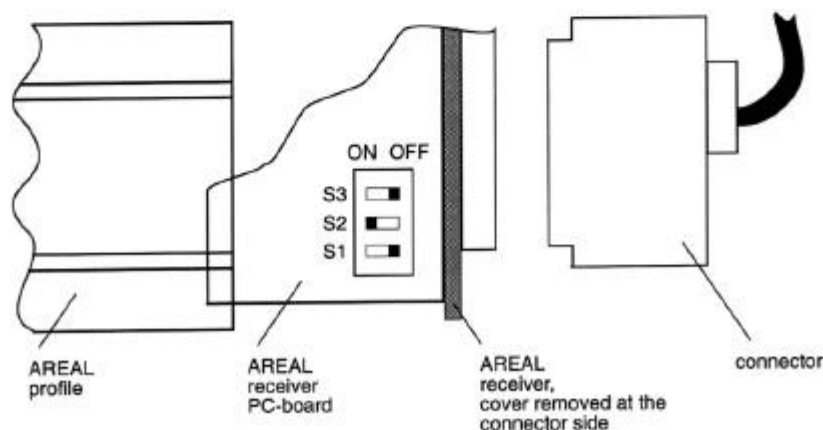

2 Scope of supply

2.1 AREAL Safety Light Grid

Nomenclature

A-400/3 stands for a 3-beam AREAL Safety Light Grid with a pitch (beam center distance) of 400 mm.

The CE sign at the label indicates, that an EEC model examination was made by a notified body according to the European Machine Directive, to the Low Voltage Directive (73/23/EEC) and to the EMC Directive (89/336/EEC) supplemented by 93/31/EEC.

The year of production and the serial number are printed onto the label, too.

Scope of supply

- 1 AT transmitter incl. connecting socket DIN 43652
- 1 AR receiver incl. connection socket DIN 43652
- 4 Angle-plates
- 1 Fitting and operating instructions

Mounting

Mounting of the AREAL is made by fixing screws (10 mm width of spanner), which are inserted into the long-slots alongside the housings. This easy fastening only allows for adjustment in vertical direction. For adjustments in more directions, additional mounting set accessories are available.

2.2 Accessories

2.2.1 Mounting sets

There are three different mounting sets available:

	Part number
Mounting set, wall without angle-plate	545001
Mounting set, wall with angle-plate	545000
Mounting set, floor/column	545012

Which one of those mounting sets is delivered together with the AREAL Safety Light Grid depends on your purchase order.

The individual mounting sets contain as follows:

Mounting set, wall without angle-plate

- 1 x Aluminium basic profile (c) with 4 slots for mounting the brackets and 4 slots for mounting onto the wall
- 2 x Mounting bracket (b)
- 2 x Metric hexagonal screws M6 x 80 (a)
- 4 x Metric hexagonal screws M6 x 12 (d) with nuts
- 2 x Washer M6, zinc coated
- 2 x Washer M6
- 10 x Spring washer

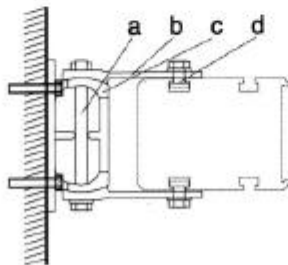

Mounting set, wall with angle-plate

1 x Angle-plate (a)

dimensions: height 600 mm, width 100 mm, depth 100 mm

4 x Metric hexagonal screw M6 x 16 (b)

4 x Spring washer M6

4 x Washer M6

all other parts according to the wall mounting set without angle-plate

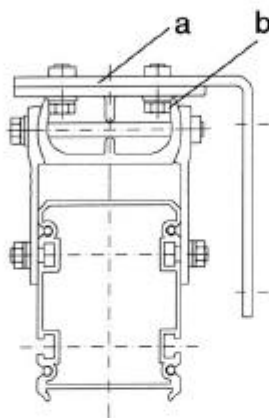

Mounting set, floor/column

- 1 x Drill-hole template
- 1 x Base plate (a) with welded-on column (b)
- 1 x Base plate
- 2 x Mounting bracket, right and left (c)
- 2 x Metric hexagonal screw M6 x 75 (d)
- 4 x Metric hexagonal screw M6 x 16 (e) with nuts
- 4 x Metric hexagonal screw M6 x 16 (e) with nuts
- 3 x Plug-through armature HST M10/50 (f) with nuts (k)
- 3 x Metric hexagonal screws for alignment M10 x 25 (g)
- 3 x Nuts M10 (k)
- 1 x Stopper
- Washers and spring washers

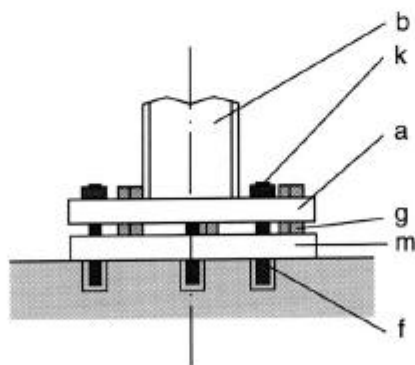
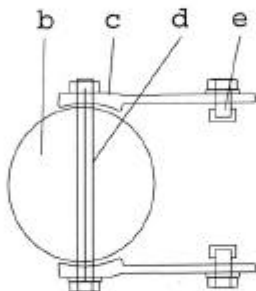

2.2.2 AC power supply unit A-PSU and relay unit A-RU

	Part number
Combination of A-PSU/A-RU	547770
A-PSU, 230 V	547771
A-PSU, 115 V	547773
A-RU	547772

2.2.3 Column with deflecting mirror

Using mirror columns, perimeter guarding can be extended to several sides. The necessary deflecting mirrors are provided by LUMIFLEX.

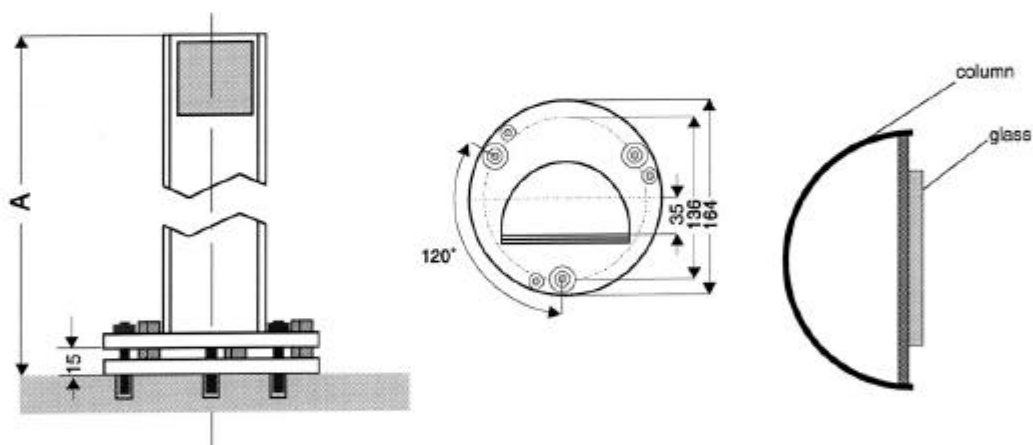

The heights of the mirror columns depend on the number of beams. The following dimensions are available:

	Part number
2-beam type - height A = 980 mm	545020
3-beam type - height A = 1180 mm	545030
4-beam type - height A = 1280 mm	545040

The individual mirrors are exactly adjusted to an optical plane. Therefore, after-treatment is not needed.

2.2.4 Laser alignment aid

For easy and precise alignment of the light grid and the deflecting mirrors, an alignment laser is offered.

This alignment laser is battery-powered and easy to mount onto the front of the AREAL. For more information see Section 5.6.

	Part number
Laserpointer	408800
Laserpointer with fixture	520001
Fixture only	408801

2.2.5 Akkalit protecting screen

For protection of the sender and receiver optics against welding splashes LUMIFLEX offers an Akkalit protection screen. An adhesive tape onto this screen allows for easy attachment.

	Part number
Akkalit protecting screen	346041

2.3 Servicing

Our technical after-sales service offers:

- Checking and inspection of the unit before initial operation
- Contract for annual maintenance
- After-sales service
- Training either at LUMIFLEX's or at the customers premises
- Fast supply of spare parts and immediate repairs

3 General safety instructions

3.1 Intended use

The AREAL Safety Light Grid serves as an electro-sensitive protecting equipment to detect a person's body. If one or more light beams are interrupted, it generates a switch-off command. It must not be used to detect fingers, hands or arms, due to the large distances between its light beams. The AREAL Safety Light Grid cannot protect against flying object hazards (e. g. parts, tools, fluids etc.)



Attention: Only those persons are detected who stay in the path of at least one light beam. Persons exterior to the sensing field are not recognized.

Consequently, the following items must be considered:

- Using AREAL as an area guarding device, it must be secured, so that nobody can stay between the sensing field of the light grid and the hazardous area.
- It must be secured, so that nobody can switch-on the machine while a person is still in the hazardous area.

3.2 Application regulations

The relevant statutory and official regulations apply concerning the use of AREAL Safety Light Grids. These regulations vary depending on the type of application. Information can be obtained from the authorities responsible for safety of machinery at your branch of industry (e. g. industrial compensation insurance companies).

- In general, positioning of the light grid must consider, that hazardous areas can only be reached through the sensing field. If this is not ensured, additional measures must be taken. If hardguarding is installed for this purpose, it must either be fixed (welded or mounted with special tools) or its position must be monitored automatically if it is required to open.

- The AREAL Safety Light Grid must be mounted in a way that overreaching, underreaching and bypassing is impossible (see Chapter 5, Fitting regulations).
- In case of area guarding, stepping-behind the light grid must be prevented.
- The control of the downstream machine must be so designed that the AREAL Safety Light Grid's switching command is processed appropriately and failsafe.
- The minimum distance must be chosen in a way which secures that a person intruding into the sensing field cannot reach the danger point(s) before the hazardous movement is brought to a complete stop (see Chapter 5, Fitting regulations).
- Starting of the first dangerous movement of the machine after power-on (releasing start interlock) and starting of the first dangerous movement after intrusion into the sensing field (releasing restart interlock) must only be possible via an external control device. This control device must be positioned in a way, which makes its controlling from inside of the danger zone impossible. From the selected position, a person must be able to overlook the complete danger zone.
- The electrical connections of the AREAL Safety Light Grid must only to be made by experts.



Attention: The fitting regulations (see Chapter 5) are to be observed.

3.3 Considered standards

Conception and development of the AREAL Safety Light Grid are based on general agreed technical rules. In particular, the following safety regulations and standards have been considered:

- pr EN 50100 part 1
Safety of machinery - Electro-sensitive protective equipment General requirements and tests
- pr EN 50100 part 2
Particular requirements for equipment using active opto-electronic protective devices
- pr EN 999
Safety of machinery, The positioning of protective equipment in respect of approach speeds of parts of the body

- pr EN 954-1
Safety related parts of the control system
- DIN VDE 0801
Fundamentals for computers in safety related systems
- VBG 4
Electrical equipment and devices
- VBG 5
Power-driven equipment
- VDE 100
Erection of high-voltage equipment up to 1000 V
- VDE 0113
Electrical equipment of machines, voltage up to 1000 V
- VDE 0160
Electronic devices for high-voltage equipment

The AREAL Safety Light Grid is self-monitoring. It is designed according to category 4, pr EN 50100 and pr EN 954-1. Failures, which can influence the safety function, will be recognized and lead to a switch-off command.

3.4 Shipping instructions

The AREAL should be shipped in the provided packaging only. Shipping has to be carried out carefully to prevent damage to optical parts and connectors.

4 Function

Two different operating modes for AREAL Safety Light Grids are available.

4.1 Operating modes

The following operating modes are possible:

- Without internal restart interlock, without external relays monitoring
- With internal restart interlock, with external relays monitoring

4.1.1 Without internal restart interlock, without external relays monitoring

After switching-on power and releasing of all light beams the output signal switching devices (OSSDs) are changing to the ON-state. The monitoring function for the external relays is not available in this operation mode.

4.1.2 With internal restart interlock, with external relays monitoring

The internal restart interlock leads to a locking state of the output signal switching devices (OSSDs) in the following situations:

- After sensing field interruptions if muting function is in OFF-state or not available
- After power-ON or power interruption

This locking situation can be released by actuating a control device. This device is effective only when the sensing field is free.



Attention: As a control device a push button, not holding its on-position, must be used. The push button must have one normally open and one normally closed contact (see Chapter 6, Electrical connections).

4.1.3 Setting the operating modes

The operating modes of the AREAL Safety Light Grid are selectable using bridges inside the receiver connector socket, pins A2, B1 and C1:

- Without restart interlock and without external relays monitoring

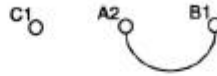

- With restart interlock and with external relays monitoring

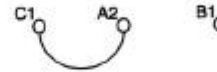

4.2 External relays monitoring

This function is only available at the operating mode "restart interlock."

The switching devices following the output signal switching devices (OSSDs) of the AREAL are being monitored. It is checked if these switching devices are back in their OFF-position before releasing the switching output again. If this condition is not fulfilled, the OSSDs do not switch to the ON-state.

With each release of the OSSDs it is checked if the feedback current at the "external relay monitoring" input is interrupted within 500 ms. This additional check prevents malfunctions caused by a short-circuit or by an external bridge. If the time-limit is exceeded, the OSSDs of the AREAL turn to an interlock condition. Only switching off power is clearing this condition.

5 Fitting



Attention: The general safety instructions (see Chapter 3) are to be observed.

5.1 Fitting regulations

5.1.1 Minimum distances of perimeter guarding (vertical position)

A minimum distance must be chosen in a way that ensures that a person intruding into the sensing field cannot reach the danger point(s) before the hazardous movement is brought to a complete stop.

The minimum distance depends on several circumstances:

- Response time of the safety light grid
- Stopping performance of the machine
- Grip and step speeds of the operator

The **minimum safety distance**, using multiple separate beams, is calculated according to pr EN 999

$$S = K \times T + 850 \text{ mm}$$

S = Minimum distance in mm, measured from the danger point to the sensing line

Using AREAL for perimeter guarding, pr EN 999 regulates the heights of the multiple beams depending on their number:

Number of beams	Height above reference plane (e. g. floor) mm
4	300, 600, 900, 1200
3	300, 700, 1100
2	400, 900

K = Approaching speed 1600 mm/s

T = Stopping time of the machine + response time of the AREAL
(3 ms + 0.32 ms per beam)

5.1.2 Minimum distances of area guarding (horizontal positioning)

A minimum distance must be chosen in a way that secures that a person intruding into the sensing field cannot reach the danger point(s) before the hazardous movement is brought to a complete stop.

The **minimum safety distance** at direction of approach parallel to the sensing field is calculated according to pr EN 999

$$S = K \times T + (1200 - 0,4 H)$$

S = Minimum distance in mm, measured from the danger point to the most distant sensing line

K = Approaching speed 1600 mm/s

T = Stopping time of the machine + response time of the AREAL
(3ms + 0.32 ms per beam)

H = Height of the sensing field above ground in mm (maximum 1000 mm)

Risk assessment must consider that at heights above 300 mm (for children younger than 14 years above 200 mm) an undetected approach underneath the sensing field is possible.

The demanded **height of the sensing field H** depends on the resolution d_{max} (mm) of the safety light grid:

$$H = 15 (d_{max} - 40) \quad \text{or} \quad d_{max} = H/15 + 40$$

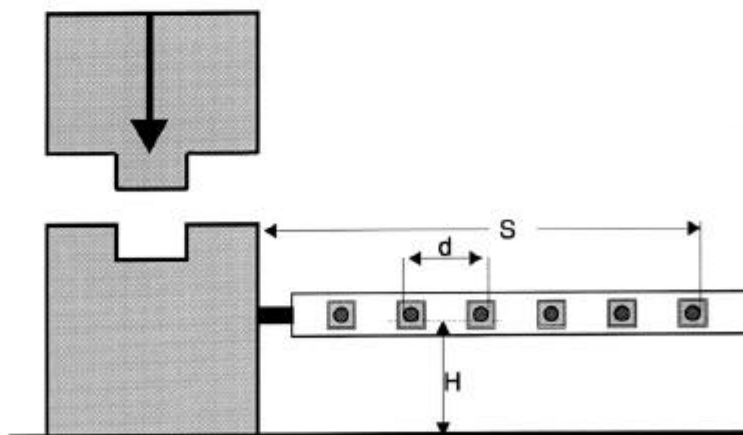

5.1.3 Distance towards reflective surfaces

The aperture angles of transmitter and receiver optics are limited to ± 2 degrees.



Attention: Reflective surfaces within a short distance of the beams can lead to the light being reflected by the reflective surface. As a result, parts of the body may not be detected. The safeguarding function of the light grid might be affected!

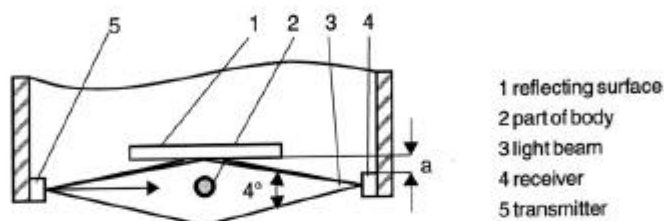

Depending on sensing field width, a certain minimum distance (a) towards reflective surfaces must be maintained. The following table shows the relationship between sensing field width and minimum distance (a):

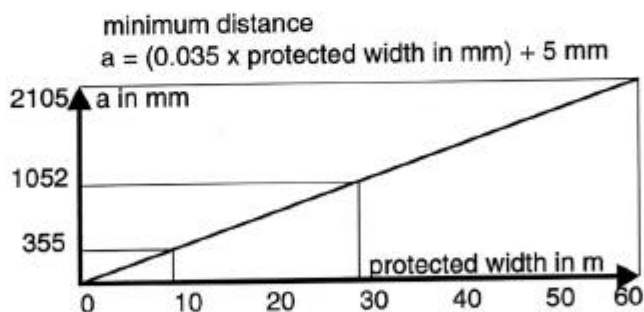

5.1.4 Mounting position

When mounting the AREAL Safety Light Grid it is essential that transmitter and receiver are mounted equally. This means the connector plugs of transmitter and receiver must aim into the same direction.

5.1.5 Avoidance of mutual interference

To avoid mutual interference it might be necessary to use a wall for optical separation.

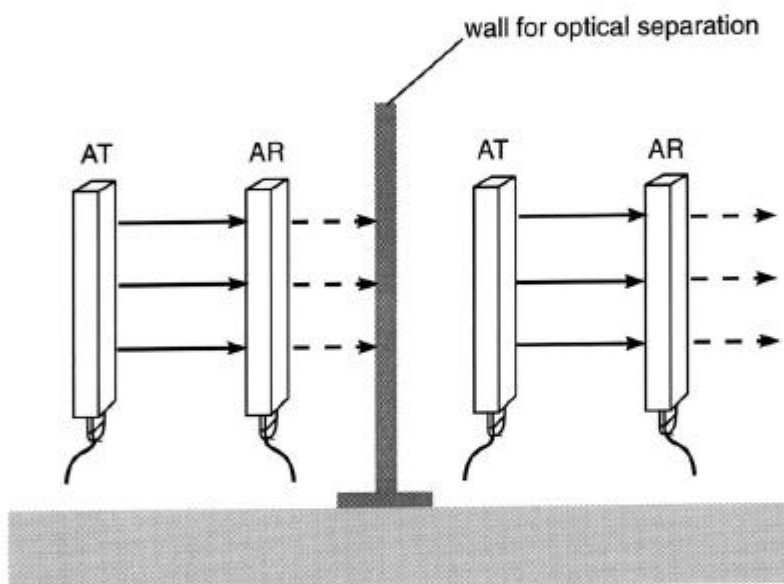

5.2 Mounting set, wall without angle-plate

1. Check if the parts of the mounting set are delivered completely.
2. Mark the position of the drill-holes onto the wall.
Mark the drill-holes at the middle of the slots.

Use the aluminium base profile as a template and a spirit-level to adjust it
The distance between the lower holes and ground must be set to 344 mm,
valid for 3-beam or 4-beam AREAL. For 2-beam AREAL the distance must
be set to 444 mm.

3. Drill the holes at the marked position.

Mount the U-shaped aluminium base profile with the 4 wall screws onto the wall.

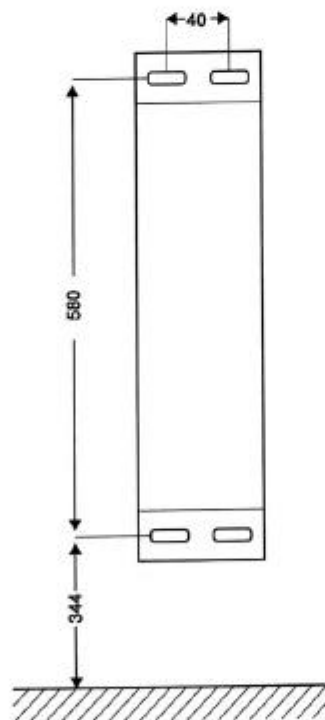

1. Use washers and spring washers.
2. Position the aluminium base profile in a way, which shows the screws in the middle of the slots.
3. Screw in slightly!

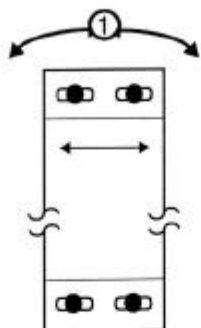
Setting possibility ①

1. Check vertical position of the aluminium base profile with spirit-level and, if needed, correct it by slight moves.
2. Tighten the screws after setting.
3. Assemble the mounting brackets to the aluminium base profile with the two metric hexagonal pin-screws.

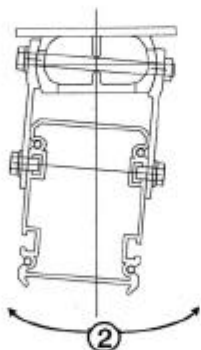
Setting possibility ②

One of the mounting brackets has a slot, the other an imbedded nut. This allows for adjustment by an angle of traverse of ± 10 degrees.

Mount the AREAL Safety Light Grid (a) to the mounting brackets.

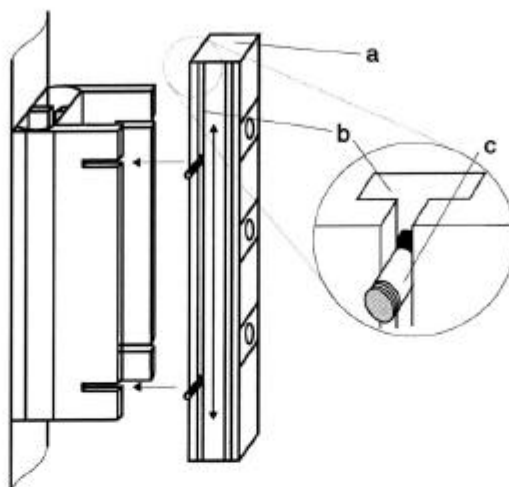

1. Guide the screw-heads of the metric hexagonal screws (c) into the long-slots (b) at the AREAL housing.
2. Hang the AREAL Safety Light Grid into the mounting brackets. The outwardly directed screws rest in the slots of the mounting brackets.
3. Set nuts with washers and spring washers onto the screws.
4. Fix the nuts slightly, but in a way, which holds the AREAL Safety Light Grid surely.

Setting possibility ③

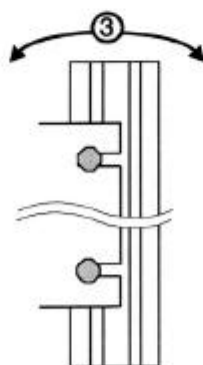

Shift the AREAL Safety Light Grid to a symmetrical position in relation to the mounting brackets. The slots at the mounting brackets allow for inclination in both directions.

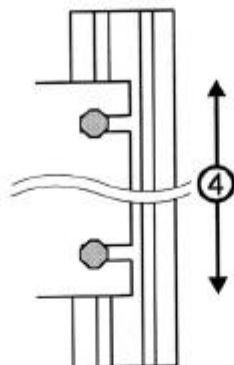
Setting possibility ④

The same screws allow for adjustment of the height of the AREAL Safety Light Grid. The screws are freely movable in the long-slots of the housing.

5.3 Mounting set, wall with angle-plate

This mounting set allows for fitting the AREAL Safety Light Grid in a way, which directs the multiple beams parallel to the wall.

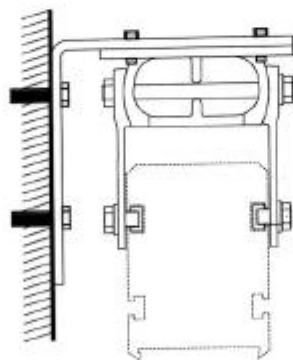

This mounting set is the same as the mounting set for walls, but includes the angle-plate. The same setting possibilities as described in 5.2 are provided. Again you have the adjustment possibilities by the long-slots.

5.4 Mounting set, floor/column

1. Check if the parts of the mounting set are delivered completely.
2. Mark the position of the drill-holes onto the floor.
Mark the position of the drill-holes.

Use the amended drill-hole template.
3. At the marked positions, put holes into the floor with a 10 mm drill (minimum depth 80 mm).
4. Screw in the 3 metric hexagonal screws (g) from the reverse side into the base plate (a).
5. Drive the plug-through armatures (f) through both of the base plates (a + m) into the drill-holes.

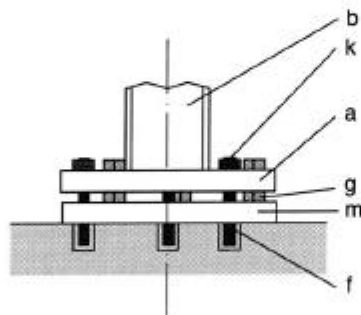

Setting possibility ⑤

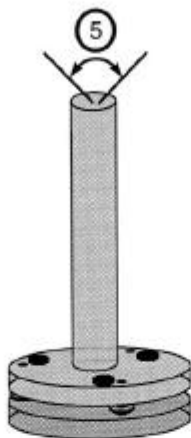

1. Before screwing on the column finally by turning in or out of the 3 metric hexagonal screws (g), make sure that the column is brought into upright position.
2. Tighten the hexagonal nuts of the plug-through armature (k).

Fix the mounting brackets (c) at the column.

This equals the mounting of the brackets to the aluminium base profile as described under wall mounting without angle-plate (see 5.2).

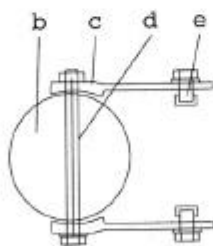
**Mount the AREAL Safety Light Grid onto the mounting brackets.**

Proceed accordingly to wall mounting (see 5.2).

Close the upper end of the column with the provided stopper.

The setting possibilities of the mounting brackets and the long-slots of the AREAL housing are the same as those of the wall mounting sets (see 5.2).

5.5 Aligning transmitter and receiver

Transmitter and receiver have to be mounted parallel and in equal height so that the transmitter light beams fall right into the receiver optics. The maximum deviation is ± 2 degrees.

Constantly shining yellow LEDs at the receiver optics indicate sufficient light energy is received.

5.6 Laser alignment aid



Warning: Make sure that nobody is looking directly into the laser beam. Warn your colleagues, before switching-on the laser!

To ease the alignment process, an alignment laser might be acquired (accessory). The alignment laser gets attached to the housing of AREAL with an easy rotating move. The sharply focused red laser beam helps to adjust transmitter and receiver.

1. Put the alignment laser (b) with its flat side parallel to the frame in front of the AREAL housing (a).
2. Turn the alignment laser until it clamps to the frame tightly
3. Switch on the laser by slowly turning the knurled screw (d). The laser stays active as long as the switch is pressed down by the screw.
4. At the opposite receiver appears a red point. Transmitter and receiver are adjusted when the red point at the receiver has the same position as the alignment laser at the transmitter.

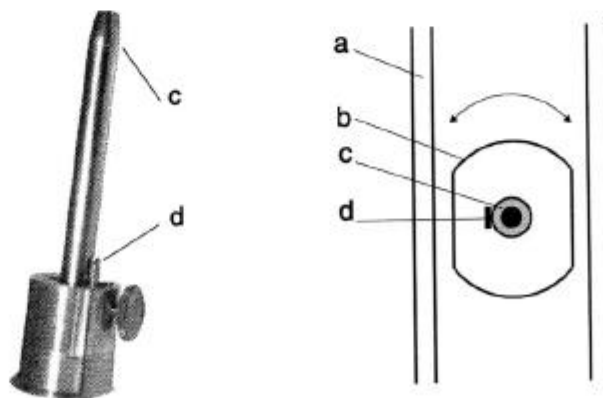

6 Electrical connections

Both, AREAL transmitter and AREAL receiver get power supplied via their plug connectors according to DIN 43652. The receiver plug connector, in addition, serves as the terminal to the machine interface. The matching connector sockets are part of the scope of delivery.

AREAL is built to the demands of interference immunity in industrial areas. However, at special applications it may happen that this level of interference is exceeded. To avoid any influence, power cables to motors or current rectifiers etc. should not run in parallel to the cables of AREAL.

Cables longer than 10 m to the AREAL must be shielded. The shield has to be connected both ends: at the protective ground of the AREAL socket and at the protective ground of the cabinet.

If the AREAL is mounted to an exposed column e. g. onto concrete, low-impedance connection of the AREAL housing to the machine ground is needed.

The robust industrial plug connectors (e. g. Harting HAN 15D) meet the demands of the standard DIN 43652.

Using a crimping tool, the individual crimp contacts are fixed to the cables as follows:

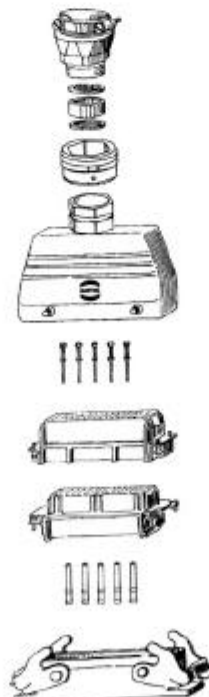

Requirements

Crimping tool, e. g. type HAN 09990000110
Cable (0.75 - 1 mm)
Isolation strip-off tool

Procedure

1. Place PG and socket housing over the cable.
2. Remove 8 mm of cable isolation.
3. Fix crimp contacts to the cables, using the crimping tool.
4. Insert the crimp contacts into the crimp terminals of the connector socket until they snap into positions audibly.
5. Join socket and socket housing.

6.1 Transmitter

Only the power supply has to be wired to the Harting connector socket of the transmitter. The annexed figure shows the connection diagram.

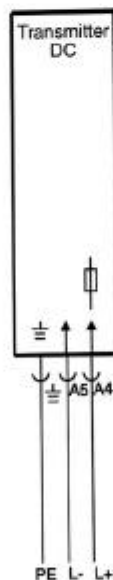
**6.2 Receiver**

Since the receiver contains the complete evaluation unit, the corresponding connection diagram is comprehensive. Diagrams, outlined onto the pages to follow, explain the machine interface.

Overview interface 24 V DC



Attention: Only the pins B2 and C2 serve for safety related outputs. Both of these outputs must be used to interrupt a dangerous movement.

The connection of the fail-safe semiconductor outputs (OSSDs) at pins B2 and C2 are explained in details onto the following pages.

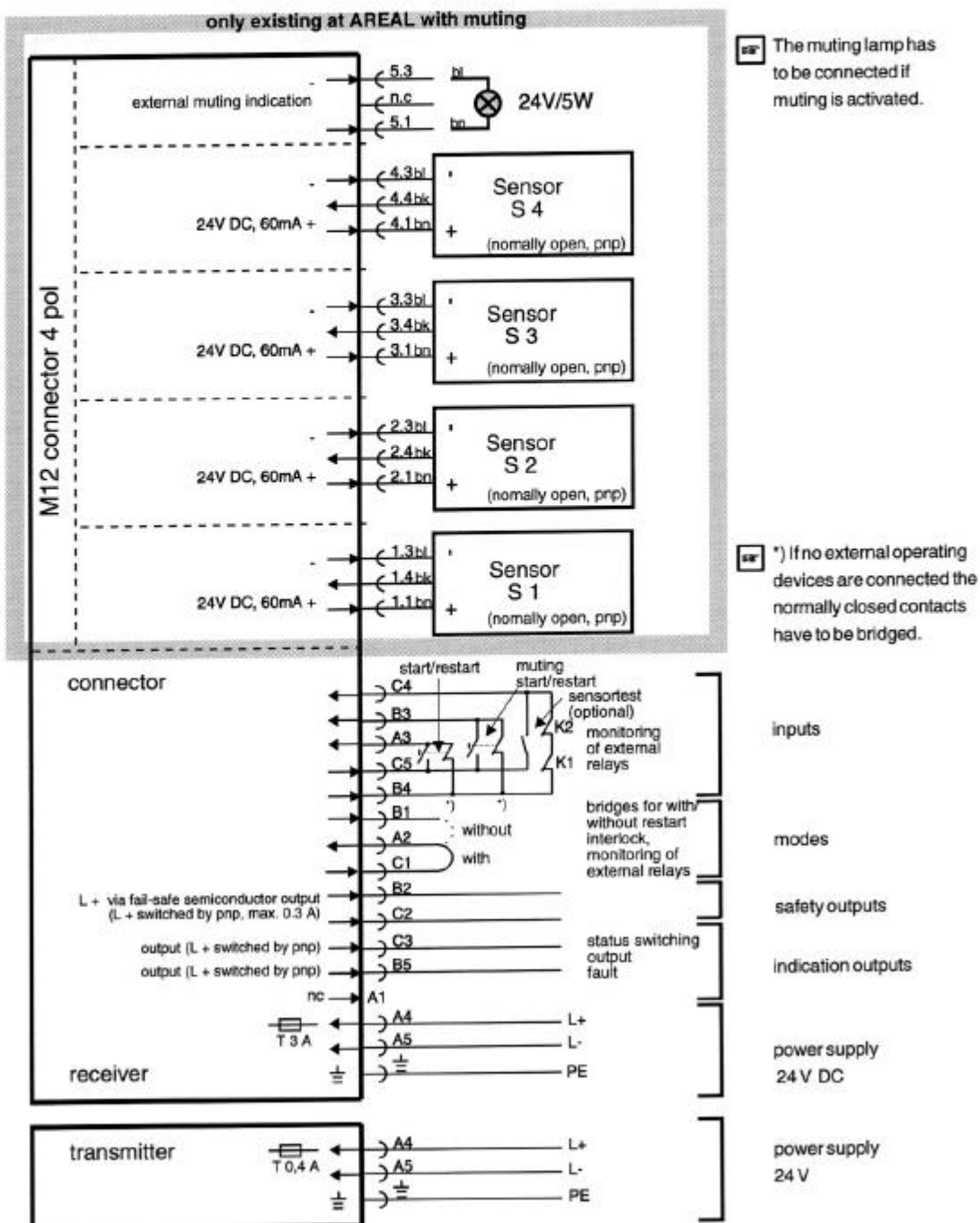

Connecting two separate external relays

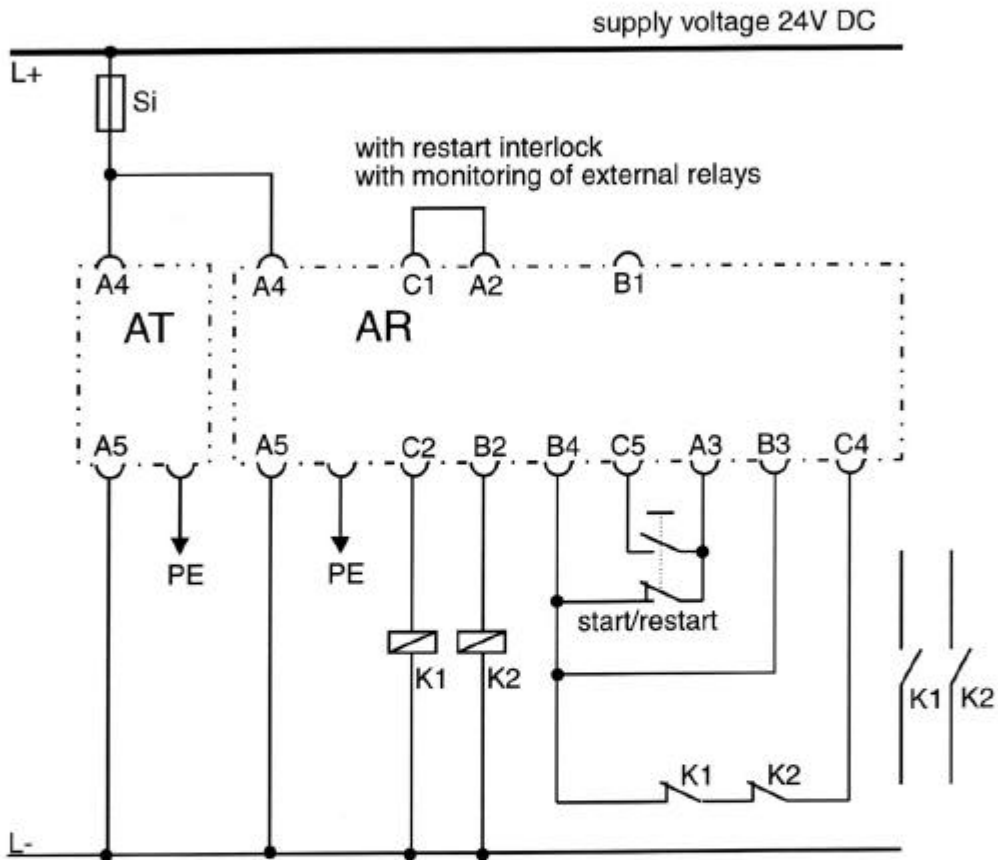

Connecting an EMERGENCY-STOP unit

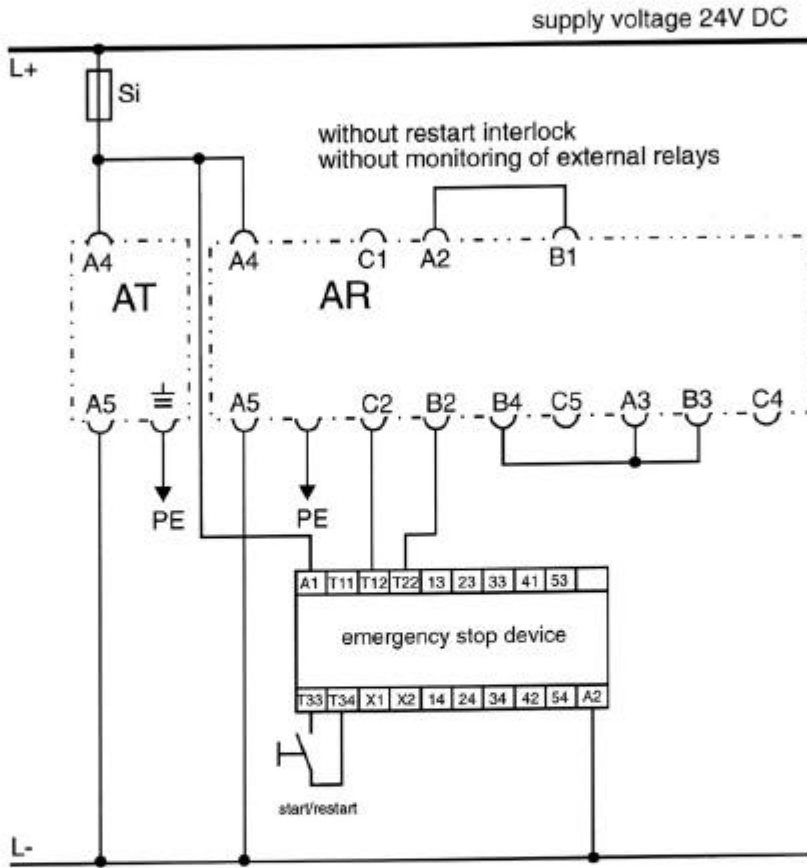

Connecting a safety related PLC

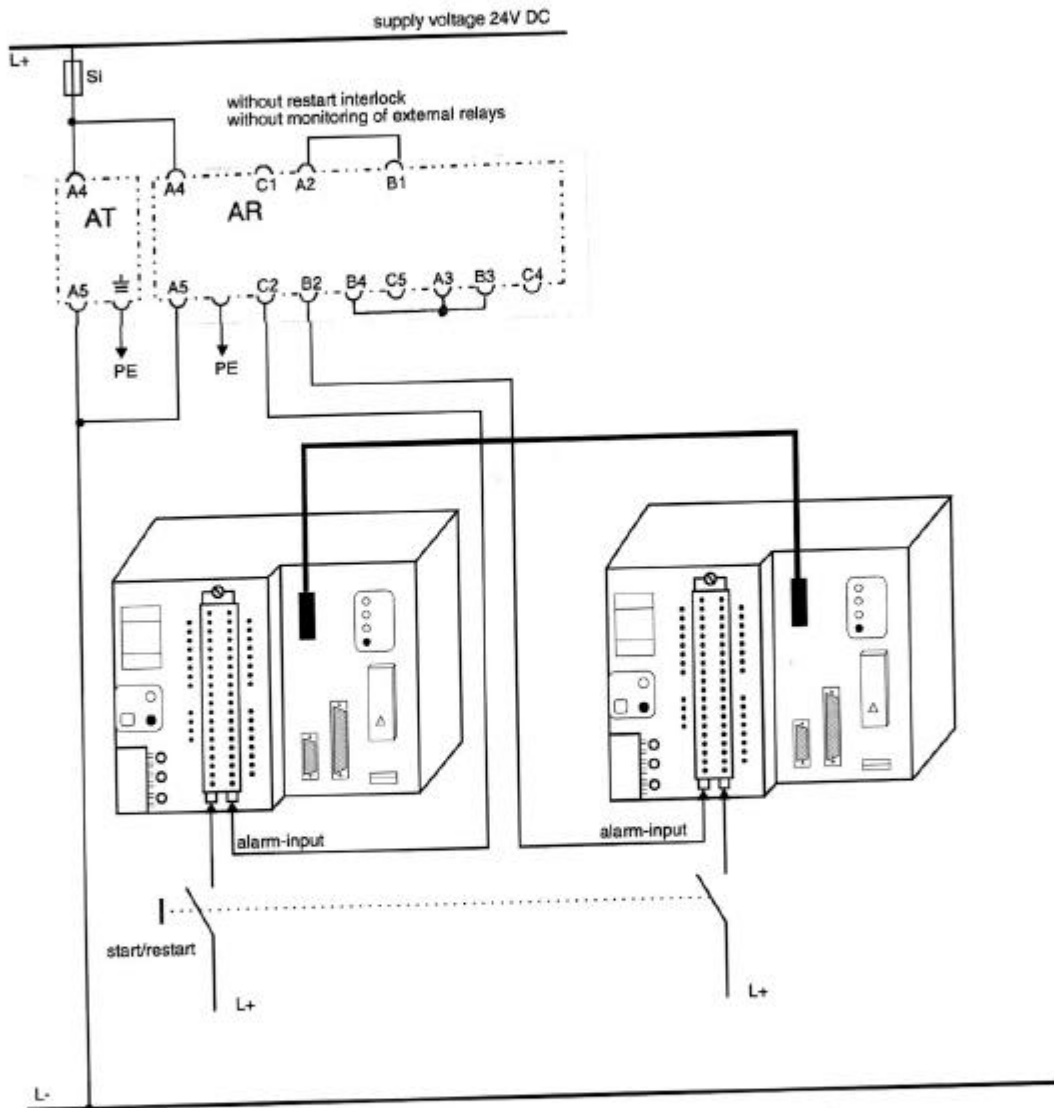

Connection using AC power supply unit A-PSU and relays unit A-RU

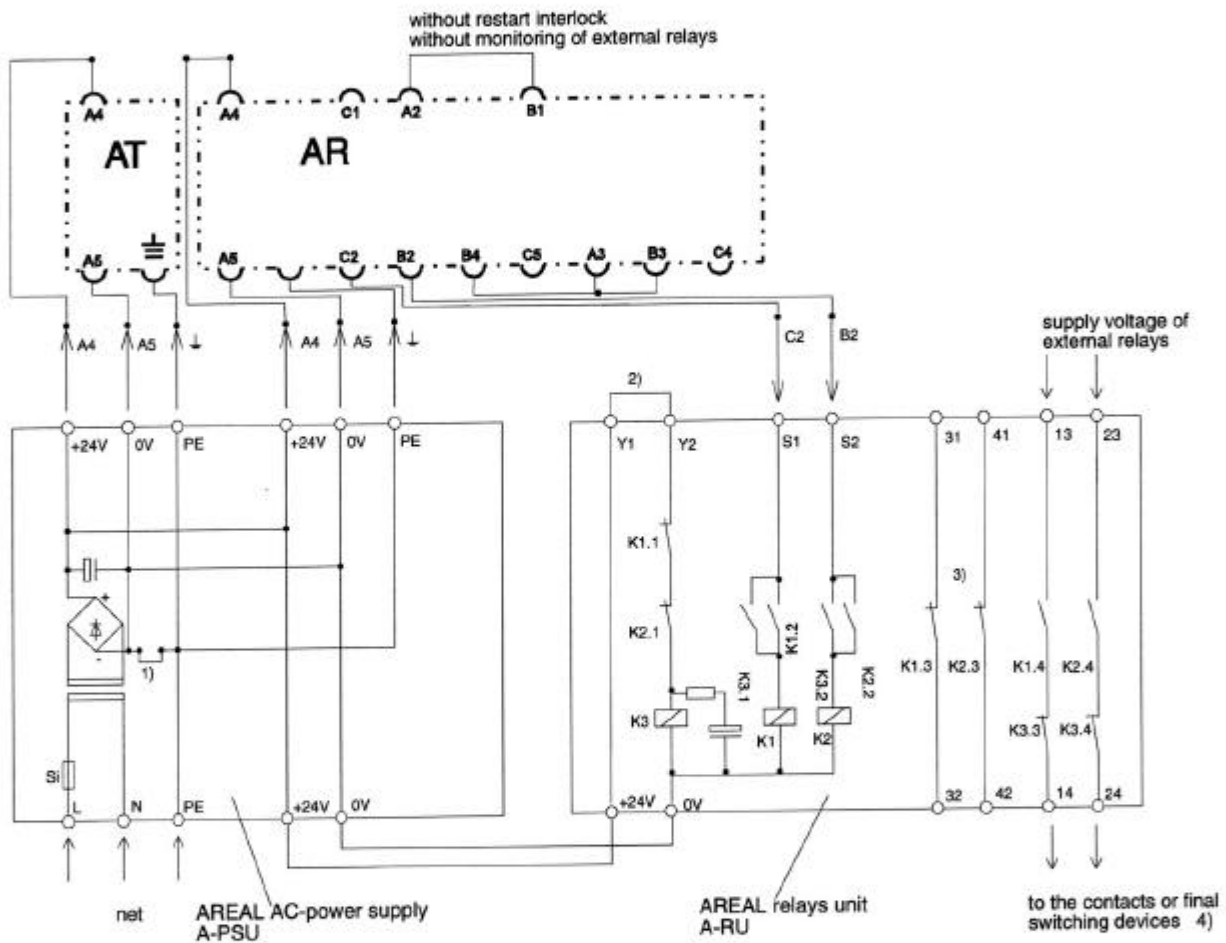

- 1) jumper according to VDE 57100 § 60 f
- 2) monitoring of external relays
- 3) auxiliary, normally closed contacts for use as safety output.
Both contacts have to be connected parallel.
- 4) Are the final switching devices and the A-RU in different housings a short circuit between the output cables has to be avoided by not using one cable.

7 Initial operation

The initial start up will depend on the selected operating mode.

Selecting the operating mode

By using the pins A2, B1 and C1 of the receiver socket, the operating mode can be selected:

- Without restart interlock and without external relays monitoring (bridge A2 -B1)
- With restart interlock and with external relays monitoring (bridge C1 - A2)

7.1 Operating mode "Without restart interlock, without external relays monitoring"

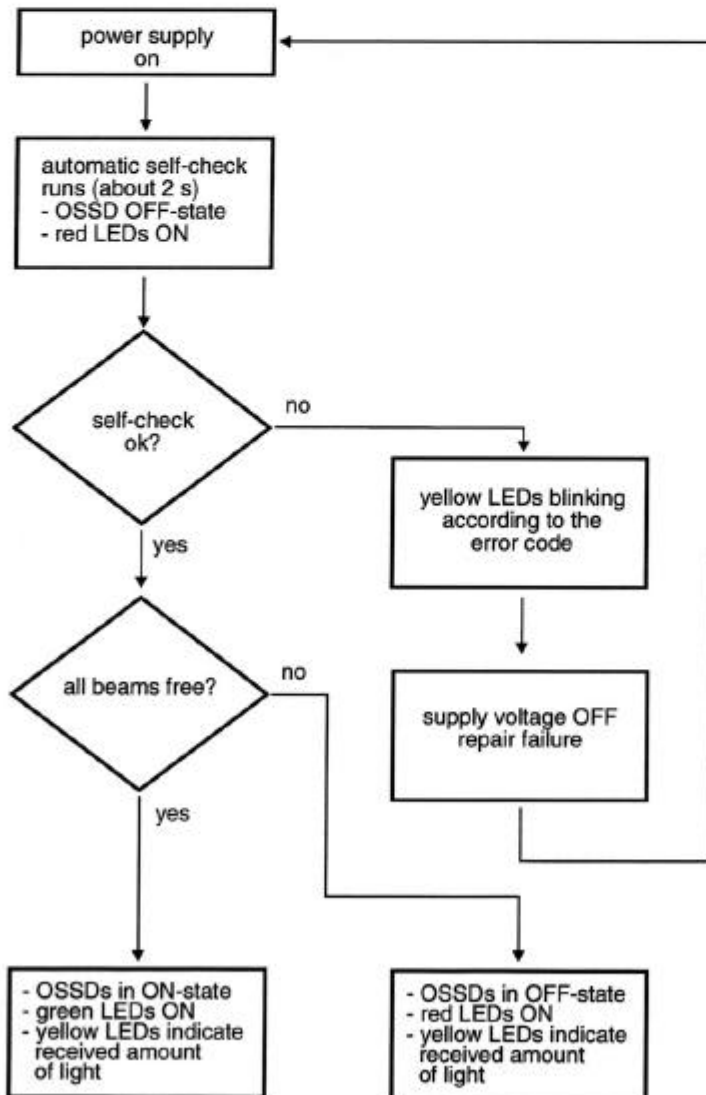

7.2 Operating mode "With restart interlock, with external relays monitoring"

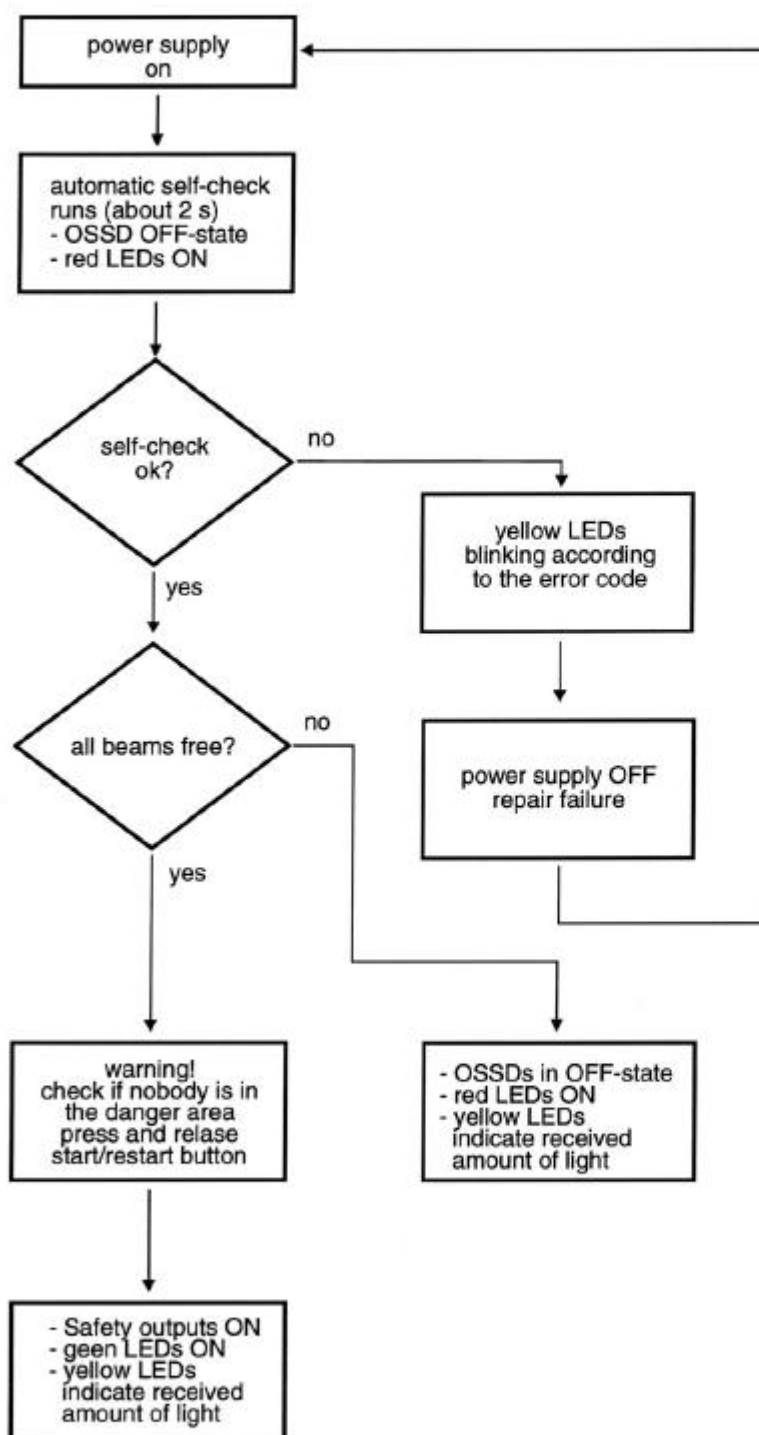

At this operation mode the AREAL monitors by a self-check routine, if the "start/restart" button is actuated during the power-on procedure. It is also checked, whether the external relays are in their normal position.

If the "start/restart" button is found actuated or the external relays are not back in their normal position during the power-on procedure, resetting the switch-off state is not possible.

8 Technical data - AREAL and AREAL-M

8.1 Common technical data for transmitter and receiver

General requirements for design	Category 4, acc. to EN 50100
Number of beams	1 - 122 due to the application
Minimum sensing field width	0.5 m
Maximum sensing field width	60 m
Response time	3 ms + 0.32 ms/beam
Range of beam distances	75 - 500 mm
Electrical protection rating	I
Enclosure rating	IP 65
Weight	approx. 2.5 kg/m
Colour	Aluminium and RAL 1021
Ambient operating temperature	- 10 °C to + 50 °C
Storage temperature	- 20 °C to + 70 °C
Aperture angle of optics	± 2 degrees
Interference immunity	acc. to IEC 801, Intensity IV
Mains buffering at rpm	10 ms

8.2 Transmitter

Supply voltage	24 V DC ± 20 %
Maximum ripple within the voltage limits	3 V peak-to-peak
Power consumption	approx. 5 VA
Type of fuse	Pico fuse M 0.4 A
Plug connector	15 pin + PE acc. to DIN 43652 e. g. Type Harting HAN 15D
PG gland fitting for cable	PG 21 with reducing rubber gasket down to a cable diameter of 7 mm

Type of connection	Crimp connection 0.75 to 1 mm AWG 18
Type of light	Infrared, pulsed
Transmitter diodes	GaAlAs diodes
Average lifetime of transmitter diodes	100.000 h
Wavelength of diodes	approx. 880 nm
Half width	approx. 80 nm
Display elements	Yellow LED

8.3 Receiver

Modes of operation	<ol style="list-style-type: none"> 1. Without restart-interlock and without external relay monitoring 2. With restart-interlock and with external relay monitoring
Available functions	<ol style="list-style-type: none"> 1. Sensor test (muting) 2. Restart interlock 3. External relays monitoring 4. Muting function
Supply voltage	24 V DC \pm 20 %
Power consumption	approx. 18 VA
Type of fuse	Pico fuse T 3 A
Plug connector	15 pin + PE acc. to DIN 43652 e. g. Type Harting HAN 15D
PG gland fitting for cable	PG 21 with rubber gasket for cable diameter of 17 mm to 19 mm
Type of connection	Crimp connection 0.75 - 1 mm AWG 18
Output signal switching devices	2 failsafe pnp semiconductor outputs $U_A = U_V - 2.7 V$, $I_{max} = 0.3 A$
Inputs	<ol style="list-style-type: none"> 1. sensor test 2. control device "Start/Restart" 3. keyed control device "Muting Start/Restart" 4. input external relays monitoring

Minimum duration of sensor test request	50 ms
Alternatively usable sensors for AREAL-M (muting) 1. Mechanical switches 2. Sensors 3. Light switches, supersonic switches	Supply voltage: 10 - 30 V DC Open-circuit current: 60 mA Output: normally open pnp
Plug connectors for sensors and muting lamp	Round 4-pin plug connector M12, screw connection
Receiver diodes	Silicon photodiodes
Spectral response bandwidth	800 nm - 1100 nm
Number of diodes	1 - 122 according to the application
Display elements	Yellow, green and red LEDs

8.4 AC power supply unit A-PSU and relays unit A-RU

General requirements for design	Category 4, acc. to EN 50100
Supply voltage	230 V respectively 115 V \pm 15 %
Frequency	50 .. 60 Hz
Power consumption	39 VA
Type of fuse	1 AT
Response time (switch-off delay)	< 6 ms
Switch-on delay	< 260 ms
Operating mode	"Guard" with automatic start
Electrical connection	with/without external relays monitoring
Switching outputs	2 potential-free make contacts 1 potential-free break contact
Indication outputs	2 potential-free break contacts (only available if the break contact is not used for switching of the safety related circuit)

Maximum power switched	250 V AC, 6 A max
Electrical durability	250 V AC, 6 A: 120 000 switching cycles 230 V, 2 A: 250 000 switching cycles
Mechanical durability	1 x 10 exp. 7 switching cycles
Electrical protection rating	I
Enclosure rating	IP 29
Ambient operating temperature	- 10 .. + 50 °C
Storage temperature	- 20 .. + 70 °C
Interference immunity	acc. to IEC 801, Intensity IV

8.5 Control devices

Control device "Start/Restart"	Push button with one normally open and one normally closed contact (e. g. Rafi)
Control device "Muting Start/Restart"	Keyed button with one normally open and one normally closed contact
Switching voltage	24 V
Switching current	10 mA

9 Diagnostics, troubleshooting - AREAL and AREAL-M

Both, transmitter and receiver are self-monitoring. Built-in tests are executed automatically. The yellow LEDs at the transmitter and receiver inserts show the test result.

9.1 Transmitter

At the transmitter, both, sufficient power supply and pulsed currents through the infrared transmitter diodes are monitored.

Yellow LEDs	Message	Action
Diode ON	pulsed current and power supply sufficient	no action
One diode OFF	pulsed current not sufficient	replace defect transmitter optic module
All diodes OFF	no power supply	check supply voltage and fuse at transmitter

9.1.1 Replacing the transmitter fuse

To replace the transmitter fuse, proceed as follows:

Requirements

Screwdriver cross-shaped (size: 2)

Screwdriver flat (size: 0.8 x 5)

Procedure

1. Remove the 4 cross-shaped screws from the bottom cover (with plug connector).
2. Open the cover carefully. The cables are holding the cover now!



Attention: To exchange the receiver fuse, pull out the electronic unit about 60 mm. The pulled electronic unit must be supported by underlying in order to avoid mechanical tensions to the printed board.

3. Open the fuse holder with the flat screwdriver.
4. Replace the fuse (M 0.5 A).
5. Shut fuse holder and bottom cover. When screwing on the bottom cover ensure that the rubber gasket fits properly to the small gaps.

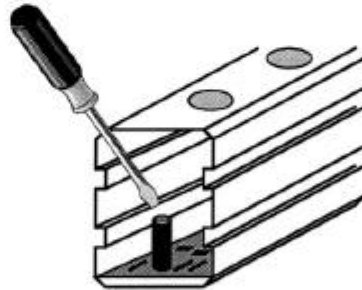
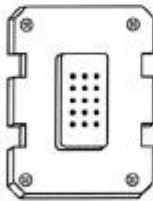

9.1.2 Replacing a transmitter optic module

The transmitter optics are held by plastic dents. To remove them from the aluminium housing, proceed as follows:

Requirements

Screwdriver flat (0.8 x 5)

Procedure

1. Put the screwdriver into the 4 openings (A), one after the other, and lift the optic module carefully.
2. Unplug the cable.
3. Replace the transmitter optic module.
4. Fit the transmitter optic module. Take care that the cable is facing to the transmitter plug connector with the LED to the left.
5. Fix the transmitter optic module by firm pressure onto the plastic frame until it snaps in.

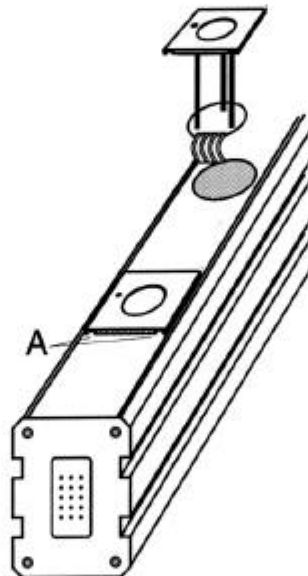
**9.2 Receiver**

If there is none of the LEDs in the ON-state:

1. Check power supply 24 V DC (+ pin A4, - pin A5)
2. Check the fuse:
remove button cover (with plug connector);
pull the electronic unit about 60 mm out of the housing and support it mechanically by underlying; open the fuse holder with the screw driver and check fuse.

The yellow LED diodes at the receiver optic modules indicate the following states:

- Contamination (permanently blinking)
- Device status (blinking sequence)
- Error (blinking sequence)

Contamination

Contamination of the optics (**M**) is indicated by a permanent blinking of the respective LED diode.

Device status

The device status indications (**M**) do not lead to an OFF-state of the switching outputs. The blinking sequence disappears as soon as the reason for it is rectified.

Per example:

4 x blinking sequence if control device "Start/Restart" is activated for more than 4 seconds.

Error

Error messages may appear either for internal system failures of AREAL (**N**) or failures caused by external connections (**R**).

Internal system failures (**N**) of AREAL lead to an OFF-state of the switching outputs. If the error message appears again after switching OFF and ON the power supply, a device failure exists.

Per example:

2 x blinking sequence indicates an internal hardware failure. System failures are indicated by the blinking sequences 2 x, 10 x, 16 x, and 17 x (see failure table).

Failures caused by external connections (**R**) lead to an OFF-state of the switching outputs, too. After debugging, the AREAL receiver turns back to normal conditions. At operation mode "with restart interlock" the control device "Start/Restart" has to be activated. At operation mode "without restart interlock" the switching outputs turn back to the ON-state automatically.

After it was shown at least twice, the blinking sequence can be reset by one of the following actions:

- By activating the "Start/Restart" button
- By activating the keyed "Muting Start/Restart" button
- By closing the sensor test contact (C4, C5)
- If there are none of the external control devices connected to the AREAL (e. g. at the mode "without restart interlock") the reset of the blinking sequence is possible by changing the switching outputs from the ON-state to the OFF-state. This might be done by interrupting the sensing field. After resetting the error message, the machine must be started again.

Blinking sequences of the yellow LED diodes of the receiver inserts

Failure types

M = device status indications, do not lead to an OFF-state of the switching-outputs.**R** = failures caused by external connections, do lead to an OFF-state of the switching-outputs.**N** = internal system failures, do lead to an OFF-state of the switching-outputs.

Blinking sequence	Message	Failure Type	Action
Permanent ON	Sufficient light energy received	-	No action.
Symmetrical blinking with 2 Hz	Weak light energy received	-	Clean the optics, check alignment.
1 x	1. Beam interrupted	M	Clean the optics, check alignment.
2 x	Internal hardware failure or wrong muting sensor control signals	N	Call LUMIFLEX Service Department. Failure can be further specified by internal LEDs.
3 x	Test input more than 4 s open, or incorrectly connected	M	Check if test button clamps or if it was activated more than 4 s. Check connections.
4 x	Control device "Start/Restart" activated for more than 4 s	M	Check if push button clamps or if it was activated more than 4 s. Check connections.
5 x	Keyed button "Muting Start/Restart" activated for more than 4 s	M	Check if keyed button is jammed or if it was activated for more than 4 s. Check connections.
6 x	Short-circuit at the switching output B2 to L- or cross-circuit	R	Check connections.
7 x	Short-circuit at the switching output B2 to L+ or cross-circuit	R	Check connections.
8 x	Short-circuit at the switching output C2 to L- or cross-circuit	R	Check connections.
9 x	Short-circuit at the switching output C2 to L+ or cross-circuit	R	Check connections.

Blinking sequence	Message	Failure Type	Action
10 x	Operating mode (restart interlock) was switched during operation or missing bridge	N	Check the bridge B1/A1 or A2/C1. Make sure that the operating mode is not changed during operation.
11 x	Muting lamp defective or differing power consumption	R	Check connection and function of the muting lamp.
12 x	C4 to B4 bridged or external relays do not switch to the ON-state (external relays monitoring)	R	Check external relays and the feedback circuit.
13 x	C4 to B4 open or external relays do not switch to the OFF-state (external relays monitoring)	R	Check external relays and the feedback circuit.
14 x	Muting sensors activated during sensor test	R	Check the muting sensors.
15 x	Muting sensor in parallel mode longer than 1 s deactivated	R	Check positioning and function of the muting sensors.
16 x	High-frequency interference (ambient light) sender defect	N	Check if another light source is shining into the receiver.
17 x	DIP-switch for muting time monitoring wrongly selected or defective	N	Check the switch positions at the receiver board.
18 x	Wrong sequence of muting sensors using sequential mode	R	Check muting sensors. Start with the control device "Muting Start/Restart."
19 x	Muting time 10-minutes exceeded	R	Check muting sensors. Start with the control device "Muting Start/Restart."

9.2.1 Replacing the receiver fuse

Replacing the receiver fuse is similar to the procedure of replacing the transmitter fuse. See item 9.1.1.

9.2.2 Replacing a receiver optic module

The replacing of a receiver optic module follows the same instructions as given for the exchange of a transmitter optic module. See item 9.1.2.

In difference to the transmitter optic module, the receiver one has 3 LEDs and is plugged to an 8-core flat strip cable. Put in the receiver insert as shown in figure (cable connection in direction of bottom plug connector, LEDs to the left).

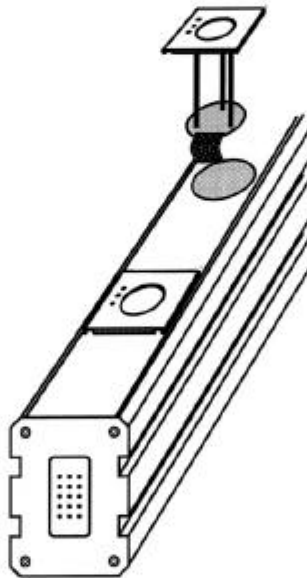

9.3 Maintenance

The light grid itself is basically maintenance-free. Occasionally the optic needs to be cleaned. Do not use aggressive solvents!

10 AREAL-M Safety Light Grid with "Muting"

The AREAL-M Safety Light Grid is a special version of AREAL. The features are described in this chapter:

10.1 Muting

The purpose of muting is to allow the uninterrupted material flow through the sensing field of AREAL without producing a stop command. To ensure this feature, the light grid's control unit must distinguish whether the sensing field is interrupted by a material transport system or by a person. The necessary information is provided by the muting sensors S1, S2, S3 and S4.



Muting suppresses the safety function of the AREAL. The entrance to and from the danger area must be designed carefully to prevent access of persons during the muting process.

All sensors must be arranged in a way that manipulation with simple methods is impossible. They might be put in place high above ground or with a large distance to each other, not reachable simultaneously by any operator and no possibility to cover to the sensors.

The AREAL-M safety light grid does not protect persons during the muting function. Operators must be instructed comprehensively about immediate hazards for persons or goods caused by manipulation or by prohibited entering the danger area. Additionally, a prominent signboard close to the entrance should point out clearly that the safety function of the AREAL-M is suppressed during the time the muting indication light is on.

Perimeter guarding with muting

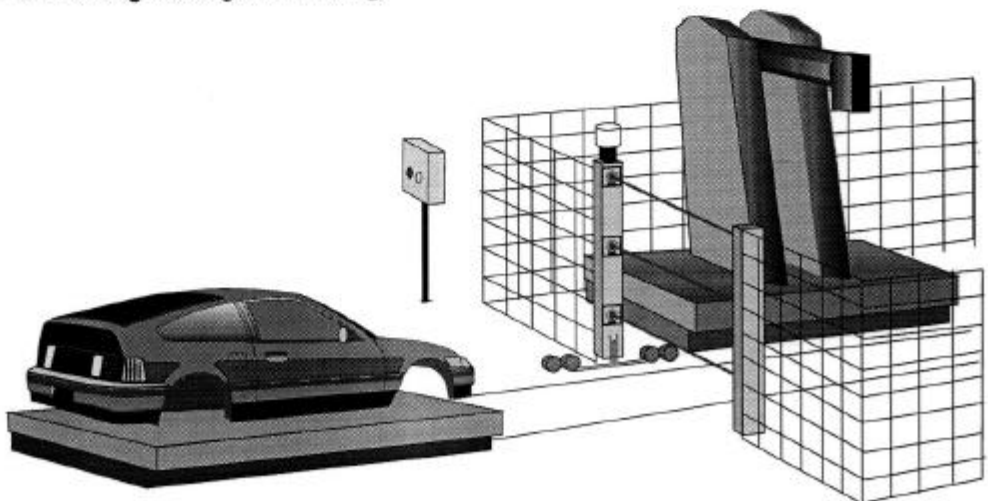

10.2 Muting sensors

There are four 4-pin plug connectors (M12) between the plug connector and the lowest receiver insert. For safety reasons, the internal power supply of AREAL provides power to the muting sensors. Their operating voltage range must be 24 V DC \pm 20%. Current consumption is limited to 60 mA each. The sensors' pnp output should be at high state (+ 24 V) if a conveyor is detected. If the sensor is not activated, high-impedance output is required.

The following muting sensors may be used:

- Proximity switches
- Mechanical switches
- Photo electric sensors (e. g. Leuze)
- Ultrasonic switches
- Induction loops

For the muting sensors, suitable cables at 2 m, 5 m and 10 m lengths are available. One end of these cables is equipped with a special plug suited for appropriate sockets of AREAL-M. The special plug carries an LED, showing the status of the sensor. The other end of these cables freely usable.

10.3 Control and indication elements

Keyed button "Muting Start/Restart"

If the option muting is used, the keyed button "Muting Start/Restart" must be connected to the AREAL receiver pin B4, C5 and B3, according to Chapter 6, Electrical connections. This keyed button must be actuated shortly to release a transport system, which is present in the muting area during switch-on power.

External indication elements

According to the standard EN 50100, a lamp showing the muting status must be connected to the output pin 5.1 and pin 5.3. Without this lamp, muting cannot start. The output is provided by a 4-pin connector plug (A1) at the top cover of the housing.

It is laid out for a bulb (5 Watts at 24 Volts). When the muting function is active, this lamp lights constantly. A blinking sequence of about 2 s is a request for reset by the keyed button "Muting Start/Restart."

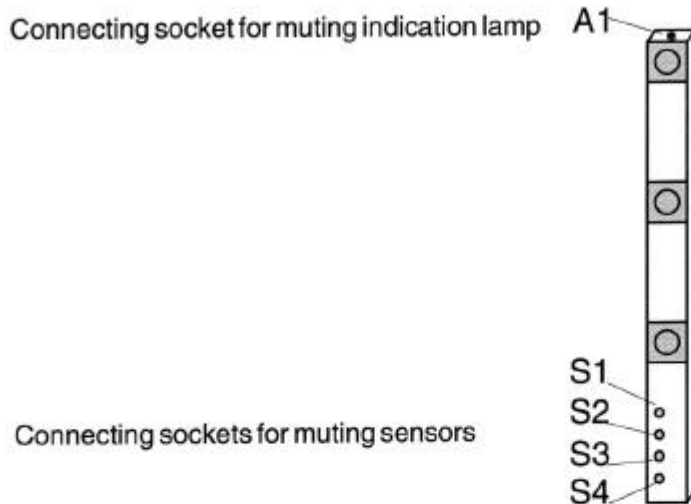

Part number

Muting indication lamp
Cable for muting indication lamp 2 m

548000

548002

10.4 Nomenclature

AM-400/3 stands for a 3-beam AREAL-M Safety Light Grid with muting function and a pitch (beam center distance) of 400 mm. The AREAL-M consists of an AT transmitter and an AMR receiver.

10.5 Operating modes

AREAL-M offers two muting modes:

- Sequential mode
- Parallel mode

Depending on the used sensor connecting sockets and sensor signals, the equipment decides automatically which of the modes has to be executed.

Sensor positioning



Attention: Using the muting function, it must be assured by proper gateway design that no person can enter the dangerous area together with the transport system. The transport system must block the entrance in a way that no person can enter. Emergency doors may prevent persons from hazards if trapped inside the danger area.

10.5.1 Sequential mode

Sequential mode is active, if the sensors S1, S2, S3 and S4 are activated successively. Required time delay of sensor activation is 60 ms minimum. The sequential mode can also operate in the reverse direction.

The following table shows the succession of the sequential mode by a transport system passing the AREAL-M Safety Light Grid:

Step	S1	S2	S3	S4	Status AREAL-M	
1	0	0	0	0	safeguarding	sequence forward
2	1	0	0	0	safeguarding	
3	1	1	0	0	muting	
4	1	1	1	0	muting	
5	1	1	1	1	muting	
6	0	1	1	1	muting	
7	0	0	1	1	muting	
8	0	0	0	1	safeguarding	
9	0	0	0	0	safeguarding	
1	0	0	0	0	safeguarding	sequence reverse
2	0	0	0	1	safeguarding	
3	0	0	1	1	muting	
4	0	1	1	1	muting	
5	1	1	1	1	muting	
6	1	1	1	0	muting	
7	1	1	0	0	muting	
8	1	0	0	0	safeguarding	
9	0	0	0	0	safeguarding	

The muting status ends when S3, respectively S2 in reverse direction, gets deactivated or the appropriate sequence is not observed.

Principle

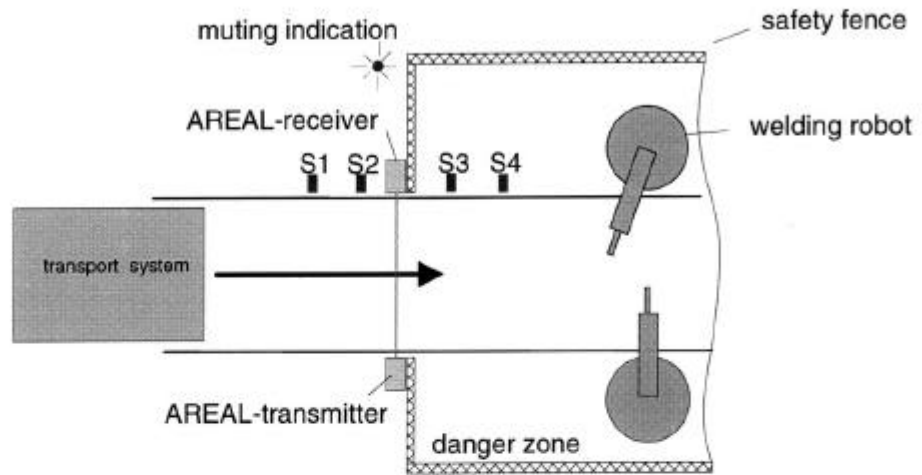

Sequential mode requires the smallest distance possible between S2, respectively S3, and the AREAL. This ensures triggering and releasing of the muting function closest to the AREAL sensing field.

Succession diagram

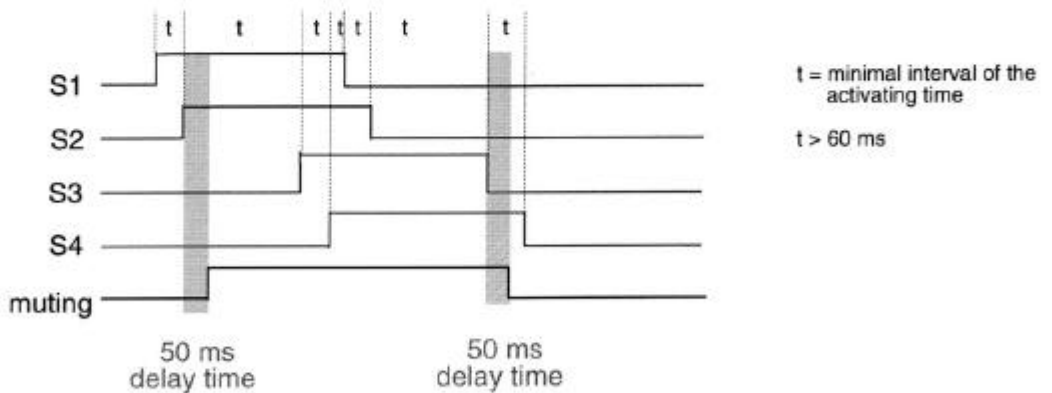

Sensor positioning

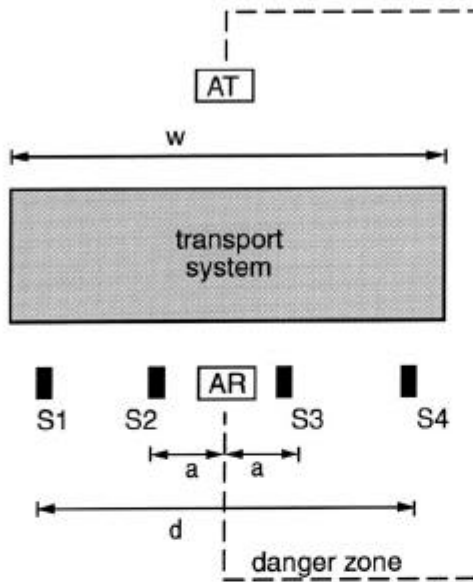

AR = AREAL-Receiver
 AT = AREAL-Transmitter
 S1, S2, S3, S4 = muting sensors
 w = length of transported material, $w > d$
 a = distance between S2, respectively S3, and the AREAL as small as possible

10.5.2 Parallel mode

Parallel mode is active, if the sensors S2 and S3 are activated within an interval of 0.7 s. After triggering the muting function, deactivation of the sensors for a short period (up to 1 s) is tolerated, if this does not effect both sensors at the same time.

Simultaneous deactivation of sensors S2 and S3 ends the muting function.

Principle/application 1

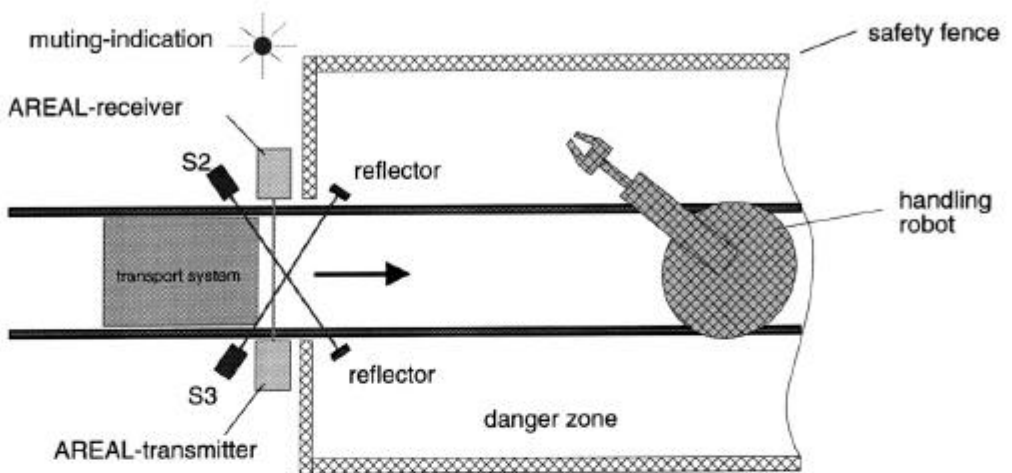

Using e.g. reflex light switches as sensors S2 and S3, it is requested that their light beams are crossing within the danger area behind the AREAL sensing field. It must be secured that a simultaneous interruption of both of the sensors' light beams by a person is not possible without interrupting the safety sensing field first.

Principle/application 2

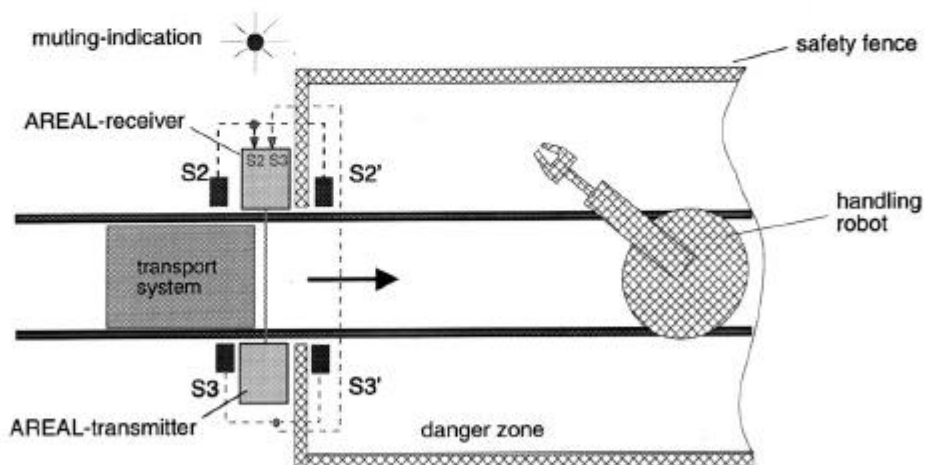

It is possible to connect two sensors each in parallel mode to the sockets of S2 and S3. The sensors S2 and S3, respectively S2' and S3', must be placed in pairs before and behind the sensing field.

Succession diagram

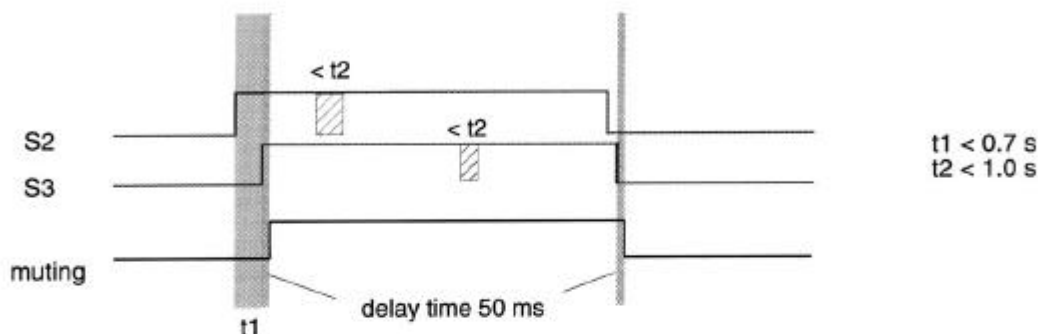

Sensor positioning

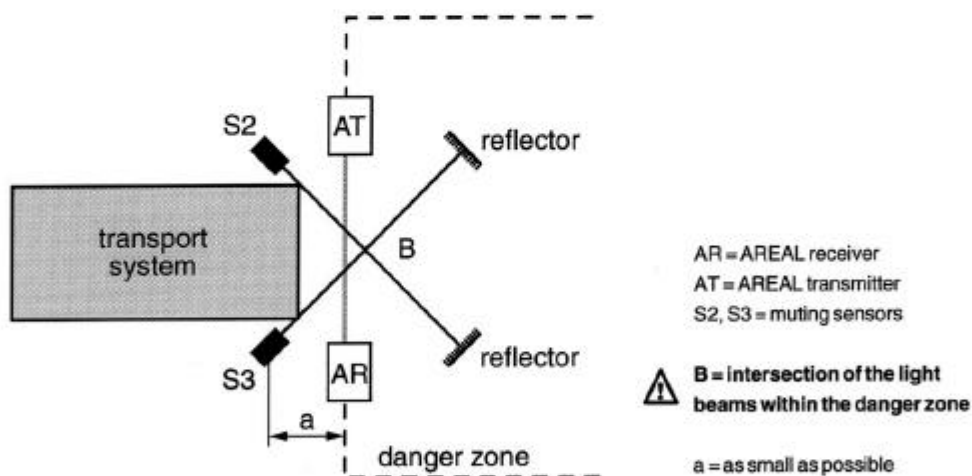

10.5.3 10-minutes muting time monitoring

In both of these modes there are time monitoring functions available. Together with the muting function an internal clock starts. If the duration of muting exceeds the 10-minutes time limit, the muting function ends automatically. Actuation of the keyed button "Muting Start/Restart" resets the internal clock. This procedure might also be used to extend the time limit automatically in case of longer muting periods.

Using the DIP-switches S2 and S3, at the receiver printed circuit board, the 10-minutes muting time monitoring can be switched on or off. For this procedure, open the plug-sided cover of the AREAL-M receiver and get out the printed circuit board about 20 mm.

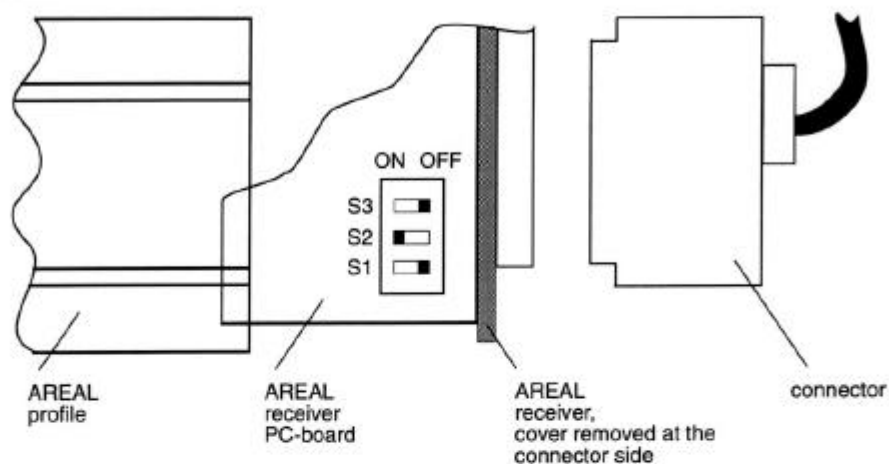

Preadjusted is the ON-state. The DIP-switch S1 permits selection to either use the output B5 to indicate "error messages" or "status of the protecting field" (all beams free yes/no).

The following table shows the DIP-switches adjustment:

Meaning	S1	S2	S3	Pread-justment
Indication output B5 "error"	OFF			yes
Indication output B5 "status protection field"	ON			no
With muting time monitoring		ON	OFF	yes
without muting time monitoring		OFF	ON	no

10.6 Setting up muting while a transport system is located in the muting area

If there is a transport system in the muting area when the system is switched on (e. g. after mains failures or emergency stops), the muting function can be set up using the keyed button "Muting Start/Restart." The same procedure is needed after interruption of the muting function caused by a wrong sequence or by reaching of any of the time limits. As a condition, at least one muting sensor must be activated. The keyed button must also be used if the operating mode "Without Restart Interlock" is chosen. Once the muting function is set up as described above, it lasts until all of the sensors are deactivated again.

10.7 Additional test facility for muting sensors by an external signal

A muting sensor test can be started optionally by closing a potential-free contact between the input pins C4 and C5.

If any of the muting sensors is active during the test, the output signal switching devices (OSSDs) of the AREAL are switching to the OFF-state and an error message appears. This interlock state is kept during failure condition. A signal from the machine control should be used to trigger the test. It must be ensured that this signal is generated only in an operating cycle where the muting sensors are usually not activated.



Diagnostics, troubleshooting AREAL-M see Chapter 9.

EC Declaration of Conformity

according to EC Machine Directive 89/392/EEC, Annex II C

We herewith declare,

LUMIFLEX ELEKTRONIK GmbH & Co KG
Ehrenbreitsteiner Straße 44
80993 München

that the following described safety components in our delivered version complies with the appropriate basic safety and health requirements of the EC Machinery Directive 89/392/EEC based on its design and type, as brought into circulation by us. In case of alteration of the safety components, not agreed upon by us, this declaration will lose its validity.

Description of the Safety Component: Safety Light Grid

Safety Component Type: **AREAL, AREAL-M**

Serial Number: see type plate

Safety Function: Electro Sensitive Protective Device

Applicable

EC Directives: EC Machinery Directive (89/392/EEC)
EC Low Voltage Directive (73/23/EEC)
EC Directive of Electromagnetic Compability (89/336/EEC)

Applicable

Harmonized Standards

especially:

EN 292-1, EN 292-2, EN 60204-1

Applicable National Standards
and other Technical Specifications,
especially:

prEN 50100-1, prEN 50100-2, prEN 999
DIN V VDE 0801

Notified Body according to
annex VII

TÜV Product Service GmbH
Ridlerstraße 31
80339 München

Responsible for:

- keeping documents according to annex VI, or
- checking for correct application of the appropriate harmonized standards and confirming the proper documents according to annex VI, or
- **EC type-examination (EC type-examination certificate no. M 6 95 0722795 001)**

Munich, 28.11.1995

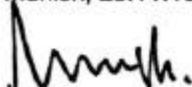

G. Greißl
Managing Director

Archives

.....
Safety Component-No..