

## Technical data sheet

### Mounting bracket

Part no.: 53800138

BTF815-30M

#### Contents

- Technical data
- Dimensioned drawings



For illustration purposes only

## Technical data

### Basic data

Application	Bracket for floor mounting
Suitable for	RSL 400 safety laser scanner

### Mechanical data

Dimension (W x H x L)	217 mm x 512 mm x 295 mm
Net weight	18,000 g
Housing color	Yellow, RAL 1021
Type of fastening, at system	Through-hole mounting
Type of fastening, at device	Screw type
Mounting device material	Metal

### Classification

Customs tariff number	73089059
ECLASS 5.1.4	27279202
ECLASS 8.0	27279202
ECLASS 9.0	27273701
ECLASS 10.0	27273701
ECLASS 11.0	27273701
ECLASS 12.0	27273701
ECLASS 13.0	27273701
ECLASS 14.0	27273701
ECLASS 15.0	27273701
ECLASS 16.0	27273701
ETIM 5.0	EC002498
ETIM 6.0	EC003015
ETIM 7.0	EC003015
ETIM 8.0	EC003015
ETIM 9.0	EC003015
ETIM 10.0	EC003015
UNSPSC 26.08	31242100

## Dimensioned drawings

All dimensions in millimeters

Scanning height 300 mm

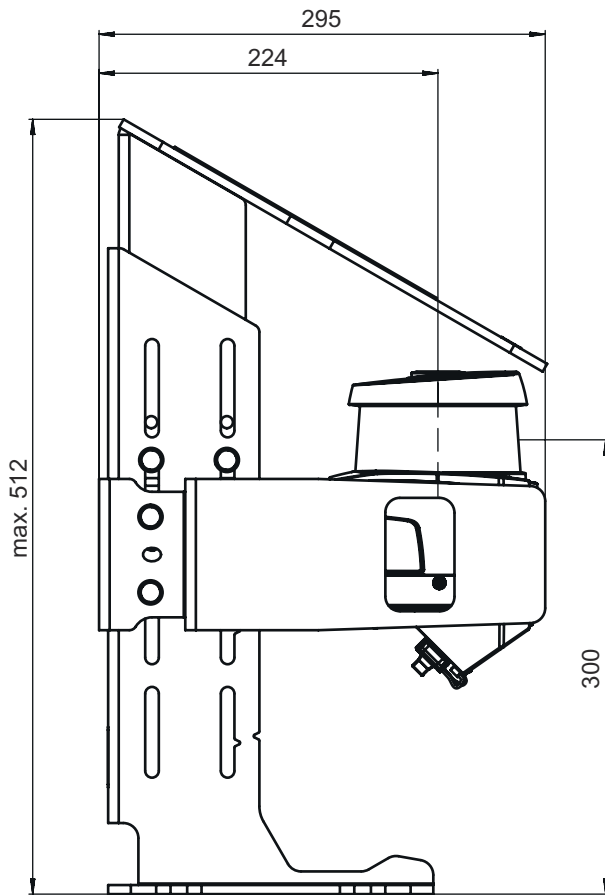

## Dimensioned drawings

Scanning height 150 mm

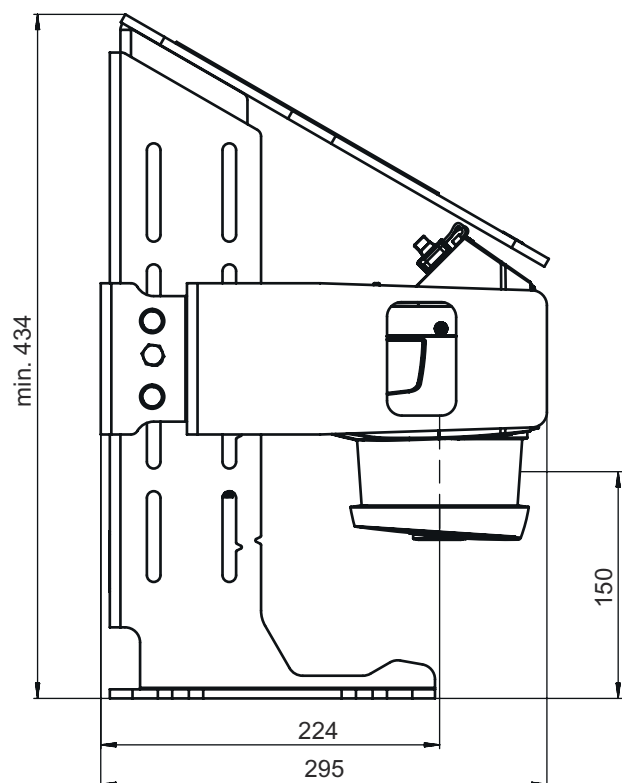

## Dimensioned drawings

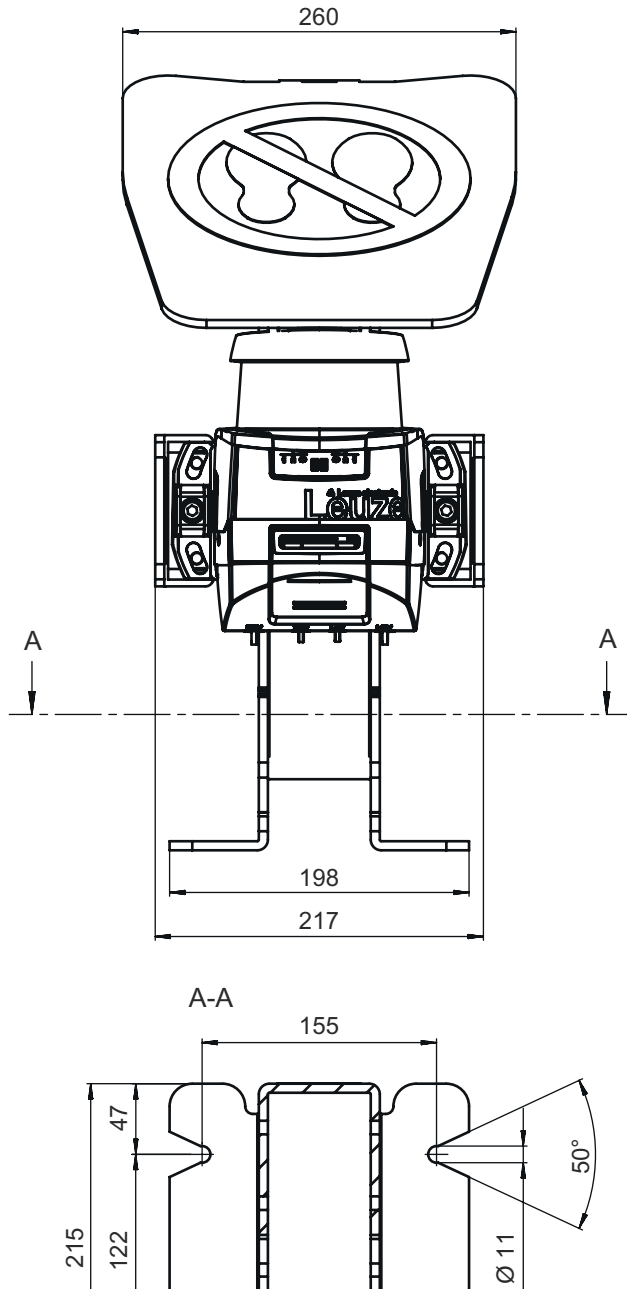

## Dimensioned drawings

