

Translation of original operating instructions

BCL 900i

Bar code scanner



© 2026

Leuze electronic GmbH + Co. KG

In der Braike 1

D-73277 Owen/Germany

Phone: +49 7021 573-0

<http://www.leuze.com>

info@leuze.com

Contents

REFERENCES VI

Reference manuals vi

Support through the website..... vi

Patents vi

CONVENTIONSVII

CONFORMITYVII

Electrical safetyvii

Laser safetyvii

Warning labels and name platesviii

Power supply ix

CSA listing ix

CE conformity ix

FCC compliance x

GENERAL VIEW.....XI

1 INTRODUCTION 1

1.1 Product description 1

1.2 Applications..... 1

1.3 Device description..... 2

1.4 BCL 900i versions..... 2

1.5 Human-machine interface..... 3

1.6 Accessories..... 4

1.7 Photoelectric sensor 5

1.8 Encoder (rotation encoder) 6

1.9 MA industrial connection unit..... 7

1.10 MSC 900 system controller..... 8

2 MECHANICAL INSTALLATION 9

2.1 Preparing for mechanical installation 9

2.2 Unpacking instructions..... 10

2.3 Installation sequence 11

2.4 What you need to know about your application 12

2.5 Installation..... 13

2.5.1 Dimensions and clearances 13

2.5.2 Requirements regarding load-bearing capacity 13

2.5.3 Operational restrictions in the case of vibration 13

2.5.4 General mounting guidelines 14

2.5.5 Considerations regarding mounting structure 15

2.5.6 Mounting the scanner..... 16

2.5.7 Positioning the scanner..... 19

3 ELECTRICAL INSTALLATION..... 20

3.1 Preparing for electrical installation 20

3.2 Connecting a BCL 900i scanner 21

3.3 Typical connection block diagrams 22

3.3.1 Connection of a single BCL 900i bar code scanner to MA 900..... 22

3.3.2 Master/slave array with MA 900..... 23

3.3.3 BCL 900i bar code scanners in an array with MSC 900 master 24

3.4 General guidelines and precautions for electrical installation 26

3.5 BCL 900i, connection fields 27

3.6	Connecting a PC to the BCL 900i	28
3.7	Table showing pin assignment of power supply connector.....	28
3.8	Power supply connections	29
3.9	MA 900 connection unit	30
3.9.1	Supply lines to MA 900 connection unit.....	30
3.10	Photoelectric sensor connections to MA 900	32
3.10.1	Photoelectric sensor (NPN).....	33
3.10.2	Photoelectric sensor (PNP).....	34
3.11	Connecting rotation encoder to MA 900	35
3.11.1	Encoder/rotation encoder wiring for NPN output (two models).....	35
3.11.2	Encoder/rotation encoder wiring for PNP output (two models).....	37
3.12	Digital output configuration to MA 900	39
3.12.1	Unpowered outputs	40
3.12.2	Powered outputs	41
3.13	Connecting to MSC 900 system controller (optional).....	42
3.14	Checking scanner installation	43
4	USER INTERFACE	44
4.1	Getting started	44
4.1.1	Requirements.....	44
4.1.2	Starting the user interface	45
4.2	User interface basics	47
4.2.1	Menu tree of BCL 900i user interface	47
4.2.2	Entering text using the Text entry tool.....	47
4.2.3	Getting help.....	48
4.3	Modify Settings	49
4.4	Modify settings System info	50
4.5	Modify settings Global settings	53
4.5.1	Modify settings Global settings Operating mode.....	54
4.5.2	Modify settings Global settings Barcode settings table	68
4.5.3	Modify settings Global settings Barcode configuration	73
4.5.4	Modify settings Global settings Serial ports	94
4.5.5	Modify settings Global settings Ethernet.....	98
4.5.6	Modify settings Global settings Messaging	105
4.5.7	Modify settings Global settings Digital I/O.....	125
4.5.8	Modify settings Global settings Diagnostics	128
4.5.9	Modify settings Global settings Energy saving.....	129
4.5.10	Modify settings Global settings HMI settings (Human-machine interface).....	133
4.6	Device settings.....	134
4.6.1	Device settings Device name Device info	135
4.6.2	Device settings Device name Mounting	137
4.6.3	Device settings Device name Options	139
4.7	Diagnosis	141
4.7.1	Diagnostics Monitor.....	142
4.7.2	Diagnostics Read test	144
4.7.3	Diagnostics Status viewer	145
4.8	Utilities	148
4.8.1	Utilities Backup or Restore.....	148
4.8.2	Utilities Reboot.....	150
4.8.3	Utilities Update firmware	151
5	BAR CODE SCANNING FUNCTIONS.....	153
5.1	Initial commissioning	153
5.1.1	Default parameters.....	153
5.1.2	Checking functions in test mode	153
5.2	Basic installation procedures with the MA 900	154
5.3	Basic installation procedures with MSC 900 controller	157
5.4	LED indicators.....	161

5.5	Control panel buttons.....	162
5.5.1	Human-machine interface.....	162
5.5.2	Restore button and other functions.....	165
5.6	PackTrack™.....	166
5.6.1	Using the PackTrack wizard.....	168
5.6.2	Calibration of top-mounted bar code scanners using PackTrack.....	171
5.6.3	Calibration of side-mounted bar code scanners using PackTrack.....	178
5.6.4	Calibration of bottom-mounted bar code scanners using PackTrack.....	185
5.6.5	Checking PackTrack calibration.....	186
5.7	Replacing an installed BCL 900i.....	188
5.7.1	Replacing a stand-alone scanner using RESTORE.....	188
5.7.2	Replacing a slave scanner in an array/tunnel automatically.....	189
5.7.3	Replacing a slave scanner in an array/tunnel using RESTORE.....	189
5.7.4	Replacing a master scanner in an array/tunnel using RESTORE.....	190
5.7.5	Checking operation of the replacement.....	191
5.8	Typical layouts.....	192
5.8.1	Large synchronized network layout.....	192
5.9	Code reconstruction technology (CRT).....	195
5.9.1	Tilt angle for code reconstruction technology.....	196
5.9.2	Minimum code height for code reconstruction technology.....	197
5.10	Reading diagram.....	199
6	MAINTENANCE.....	209
6.1	Overview.....	209
6.2	Maintenance tasks.....	210
6.2.1	Cleaning the exit window.....	211
6.2.2	Cleaning the photoelectric sensor.....	212
6.2.3	Cleaning the rotation encoder.....	213
6.2.4	Tightening mounting hardware.....	214
6.2.5	Checking bar code scanning system connections.....	214
6.2.6	Checking bar code scanner operation.....	214
6.2.7	Checking photoelectric sensor operation.....	214
6.2.8	Checking rotation encoder operation.....	215
7	TROUBLESHOOTING.....	216
7.1	Error codes and resolutions.....	217
8	TECHNICAL FEATURES.....	222
8.1	Technical specifications.....	222
INDEX	225

REFERENCES

REFERENCE MANUALS

Manuals relating to the BCL 900i are listed below:

- Installation manuals for MA 900 connection unit
- Installation manuals for MSC 900 controller

SUPPORT THROUGH THE WEBSITE

On its website, Leuze electronic provides various services as well as technical support. For further information, log on at www.leuze.com and click **PRODUCTS**:

- **PRODUCTS – STATIONARY BAR CODE READERS**

Select your product under the links on the **Stationary bar code readers** page. The product page provides specific info, features, applications, models, accessories and downloads including documentation, software, drivers and utility programs.

PATENTS

This product is covered by one or more of the following patents:

Utility patents: EP0789315B1, EP0851376B1, EP0926615B1, EP0959426B9, EP1217571B1, EP1363228B1, JP4033958B2, JP4376353B2, US5992740, US6177979, US6347740, US6394352, US6443360, US6527184, US6629639, US6742710

CONVENTIONS



WARNING OR CAUTION: this symbol identifies a hazard or procedure that, if incorrectly performed, could cause personal injury or result in equipment damage. It is also used to bring the user's attention to details that are considered IMPORTANT.



CAUTION HIGH VOLTAGE: this symbol alerts the user that they are about to perform an action involving a dangerous level of voltage, or warns against an action that could result in damage to devices or electrical shock.



CAUTION LASER: this symbol alerts the user that they are about to perform an action involving possible exposure to laser light radiation.



CAUTION ESD: this symbol identifies a procedure that requires you take measures to prevent electrostatic discharge (ESD), e.g. use of an ESD wrist strap. Circuit boards are most at risk. Please follow the ESD procedures.



PLEASE NOTE: this symbol draws attention to details or procedures that may be useful in improving, maintaining or enhancing the performance of the hardware or software being discussed.

CONFORMITY

ELECTRICAL SAFETY

At the date of manufacture, this product conforms to the applicable requirements contained in the European standard for electrical safety EN 60950.

LASER SAFETY

The following information is provided to ensure compliance with the rules imposed by international authorities and refers to the correct use of the BCL 900i bar code scanners.

Laser warning notices



ATTENTION, LASER RADIATION – CLASS 2 LASER PRODUCT



Do not stare into beam!

The device satisfies the requirements of IEC 60825-1:2014 / EN 60825-1:2014+A11:2021 safety regulations for a product of **laser class 2** and complies with 21 CFR 1040.10 except for conformance with IEC 60825-1 Ed. 3., as described in Laser Notice No. 56, dated May 8, 2019.

- Never look directly into the laser beam or in the direction of reflected laser beams! If you look into the beam path over a longer time period, there is a risk of injury to the retina.
 - Do not point the laser beam of the device at persons!
 - Interrupt the laser beam using a non-transparent, non-reflective object if the laser beam is accidentally directed towards a person.
 - When mounting and aligning the device, avoid reflections of the laser beam off reflective surfaces!
 - **CAUTION!** Use of controls or adjustments or performance of procedures other than specified herein may result in hazardous light exposure.
 - Observe the applicable statutory and local laser protection regulations.
 - The device must not be tampered with and must not be changed in any way. There are no user-serviceable parts inside the device.
- CAUTION!** Opening the device may result in hazardous radiation exposure!
Repairs must only be performed by Leuze electronic GmbH + Co. KG.

⚠ ATTENTION, LASER RADIATION – CLASS 2 LASER PRODUCT

- The bar code reader emits a moving laser beam that scans the reading field. Here, the laser is operated in CW mode. A scanning laser beam in CW mode creates the perception of repeating laser impulses if you inadvertently look into the beam. In this case, the average laser power entering the eye is <math>< 1 \text{ mW}</math>.

WARNING LABELS AND NAME PLATES

The warning label on the front of the bar code scanner indicates exposure to laser light and the device classification.

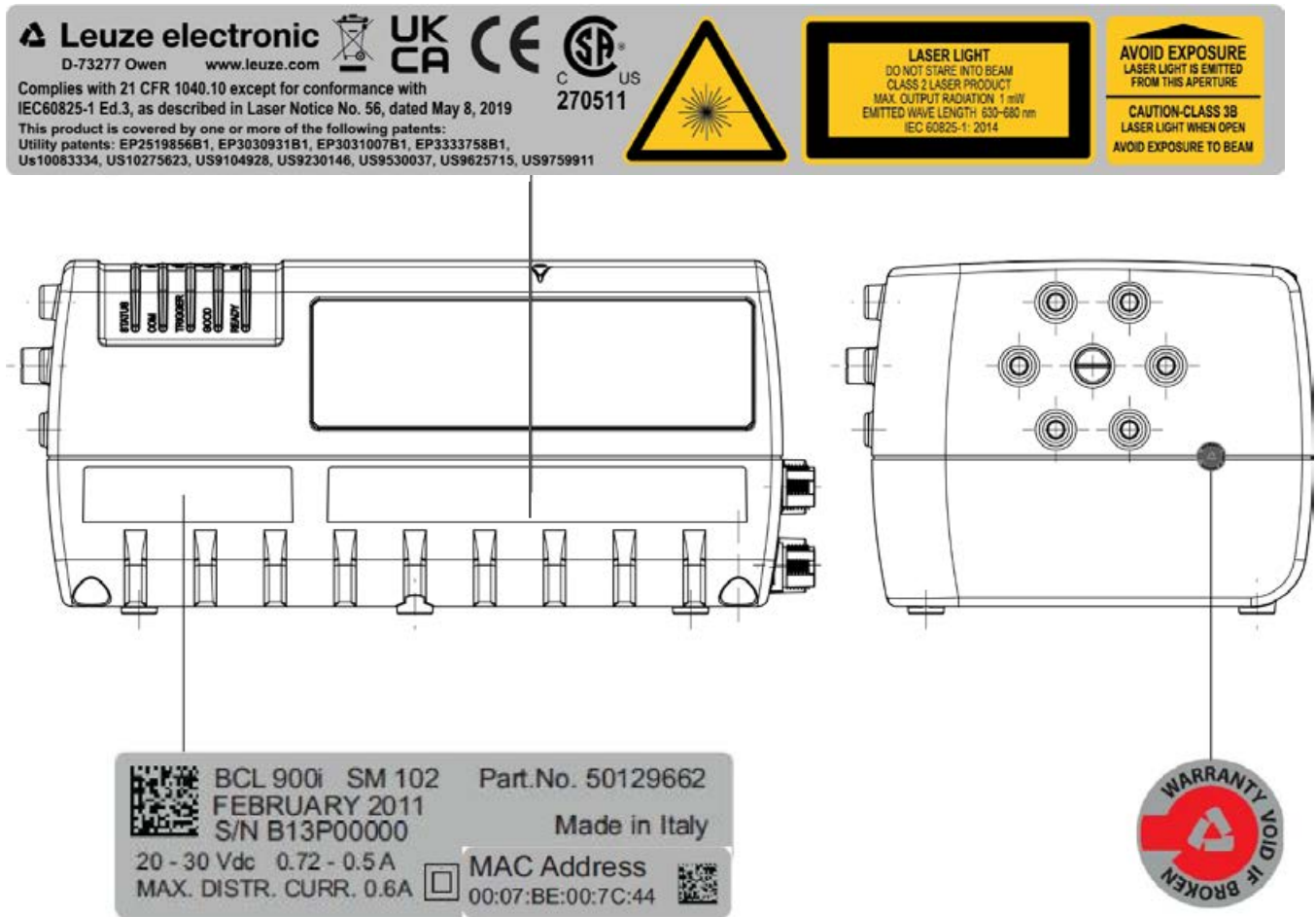

Figure 1: Labels with warning notice and device class

Produit(s) conforme selon 21CFR 1040.10 sauf des dérogations relatives à la Laser Notice N° 56, date 8 mai 2019.

Dans le paquet il y a l'étiquette(s) pour les pays où le texte d'avertissement en français sont obligatoires. Le(s) mettre sur le produit à la place de la version anglaise.



Figure 2: Exemple d'étiquettes d'avertissement laser



WARNING: disconnect the power supply when installing the device or during maintenance to avoid unintentional exposure to laser light.



WARNING: there are no user-serviceable parts inside the bar code scanner. Maintenance should only be performed by technicians trained and certified by Leuze electronic.

Any damage, particularly to the optical parts, can result in exposure to Class 3B laser light.

POWER SUPPLY

This product is intended to be installed by qualified personnel only. This product is intended to be supplied by a UL-listed or CSA-certified "Class 2" power supply unit or an LPS power supply unit.

CSA LISTING



Certificate: 70142117

3862 13 INFORMATION TECHNOLOGY EQUIPMENT-(CSA 60950-1-07, Second Edition) 3862 93 INFORMATION TECHNOLOGY EQUIPMENT-(UL 60950-1, Second Edition - Certified to U.S. Stds)

Unattended scanning system, models BCL 900i-XYWZ, rated 20-30 VDC 0.72-0.5 A and 20-30 VDC 1-0.7 A

CE CONFORMITY



WARNING: this is a Class A product. In a domestic environment, this product may cause radio interference, in which case the user may be required to take adequate measures.

FCC COMPLIANCE



Modifications or changes to this equipment without the express written approval of Leuze electronic will void the operating authorization.

This device complies with PART 15 of the FCC rules. Operation is subject to the following two conditions: (1) This device may not cause harmful interference, and (2) this device must accept any interference received, including interference which may cause undesired operation.

This equipment has been tested and found to comply with the limits for a Class A digital device, pursuant to part 15 of the FCC rules. Devices of this class provide reasonable protection against harmful interference when operated in a commercial environment. This equipment generates, uses and can radiate radio frequency energy and, if not installed and used in accordance with the instruction manual, may cause harmful interference to radio communications. Operation of this equipment in a residential area can cause harmful interference in which case the user will be required to eliminate the interference at his own expense.

GENERAL VIEW

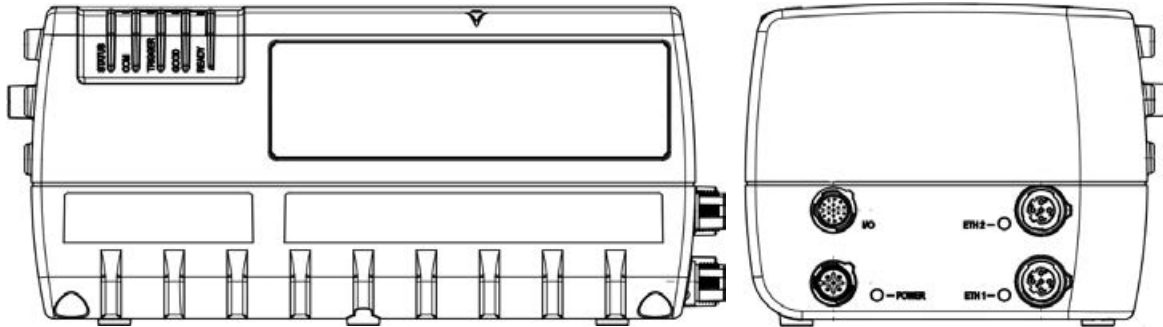

Figure 3: Front and side view (left side) of BCL 900i bar code scanner

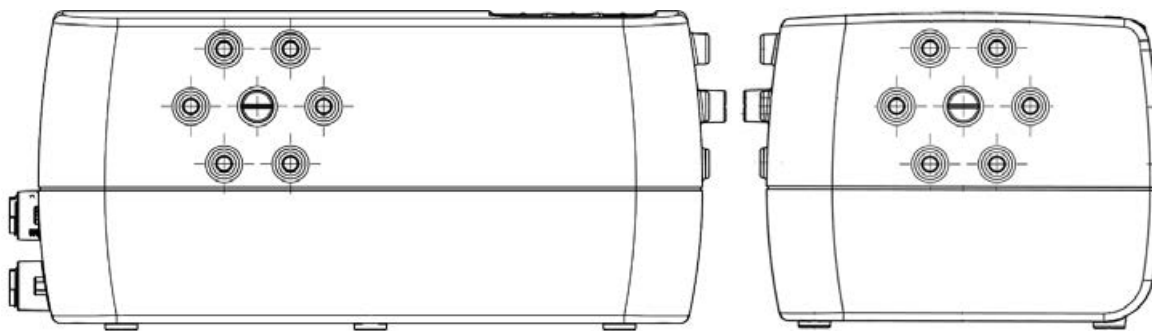

Figure 4: Rear and side view (right side) of BCL 900i bar code scanner

1 INTRODUCTION

1.1 PRODUCT DESCRIPTION

The BCL 900i bar code scanner complete with decoder is designed to provide an innovative and high-performance solution in omnidirectional reading applications by combining the following advanced technologies with Leuze electronic's solid experience in the material handling sector.

Some of the key features of the BCL 900i are listed below:

- Scanning speed 1000 scans/sec
- Reads all commonly used codes
- Supply voltage from 20 to 30 VDC
- Test mode for checking the reading features and for exact positioning of the scanner without the need for external tools
- Programmable in several different operating modes to ensure adaptability to the many different system requirements of bar code reading
- Light source: solid-state laser diodes; the light emitted has a wavelength between 630 and 680 nm. For laser safety precautions, refer to the "Compliance" section at the beginning of this manual

1.2 APPLICATIONS

The BCL 900i bar code scanners are specifically designed for industrial applications and for all cases requiring high reading performance such as:

- Code reconstruction technology (CRT)
- Reading of codes covered by plastic film
- Reading of codes with a wide depth of field
- Reading of codes within a wide field of view
- Reading of high-resolution codes positioned at long distances from the reader
- Code reading on fast moving objects

These bar code scanners are designed for both single-reader layouts and multi-reader layouts. For typical layouts, see *section 5.8*.

1.3 DEVICE DESCRIPTION

The BCL 900i bar code scanner is available in versions that differ with respect to the interface connection, the optical resolution and the optics version:

1.4 BCL 900i VERSIONS

Model	Description	Part no.
BCL 900i SN 102	High-density resolution	50129661
BCL 900i SM 102	Medium-density resolution	50129662

1.5 HUMAN-MACHINE INTERFACE

The BCL 900i bar code scanner has two external buttons that serve as the HMI interface and perform specific functions without needing to set up a connection to the **BCL 900i user interface**. See 5.5 for the functional description.

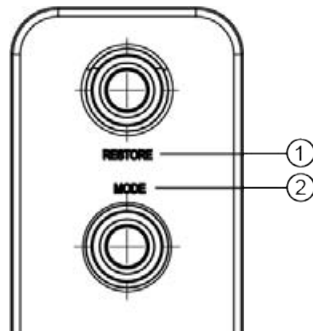

- ① RESTORE
- ② MODE

Figure 5: BCL 900i interface buttons



NOTE: some of these functions can be performed via the user interface.
See *chapter 4*.

1.6 ACCESSORIES

The following accessories are available on request for the BCL 900i bar code scanner.

Designation	Description	Part no.
Cables and terminating resistors		
KB 900 - 1000 MSC	Interface cable, 1 m, between MA 900 and MSC 900	50131533
KB 900 - 1000	Cable, 1 m	50131531
KB 900 - 3000	Cable, 3 m	50131529
KB 900 - 5000	Cable, 5 m	50131532
Connection units		
MA 900	Connection unit for BCL 900i	50129663
Controller		
MSC 900 - 1000	Controller (standard)	50129664
MSC 900 - 1100	Controller (PROFIBUS)	50129665
MSC 900 - 1200	Controller (PROFINET)	50129666
Mounting brackets		
BT 900	BCL 900i mounting bracket	50131534

1.7 PHOTOELECTRIC SENSOR

The optional photoelectric sensor is used in bar code scanner systems to detect the presence of an item in the scanning area.

The photoelectric sensor is used in singulating systems where the packages are separated by a gap between the trailing edge of one package and the leading edge of the next. The photoelectric sensor, along with the encoder, enables a programmable transmit point at a defined distance from the sensor. Without the photoelectric sensor, the bar code scanner can be run in continuous mode. See **4.5.1 Modify settings | Global settings | Operating mode**.

These devices must be configured differently depending on the application. While the photoelectric sensor and rotation encoder work well with belt conveyors, a special configuration is needed for tilt-tray and cross-belt sorter applications. See *section 3.10 for wiring options*.

1.8 ENCODER (ROTATION ENCODER)

The tachometer provides a continuous pulse to the system, which provides feedback on conveyor speed and transmit point, and can be used to help track the package position along the length of the conveyor. See section 3.11 for wiring options.

1.9 MA INDUSTRIAL CONNECTION UNIT

The MA series consists of industrial connection units that can be used to connect the bar code scanners to an encoder/tachometer, photoelectric sensor, serial devices, relays or other peripherals. The MA 900 includes a backup module, which allows easy restore and backup of parameters. The backup module also provides an easy way to upload existing parameters to a replacement bar code scanner when necessary. See section 3.9.1 for wiring options.

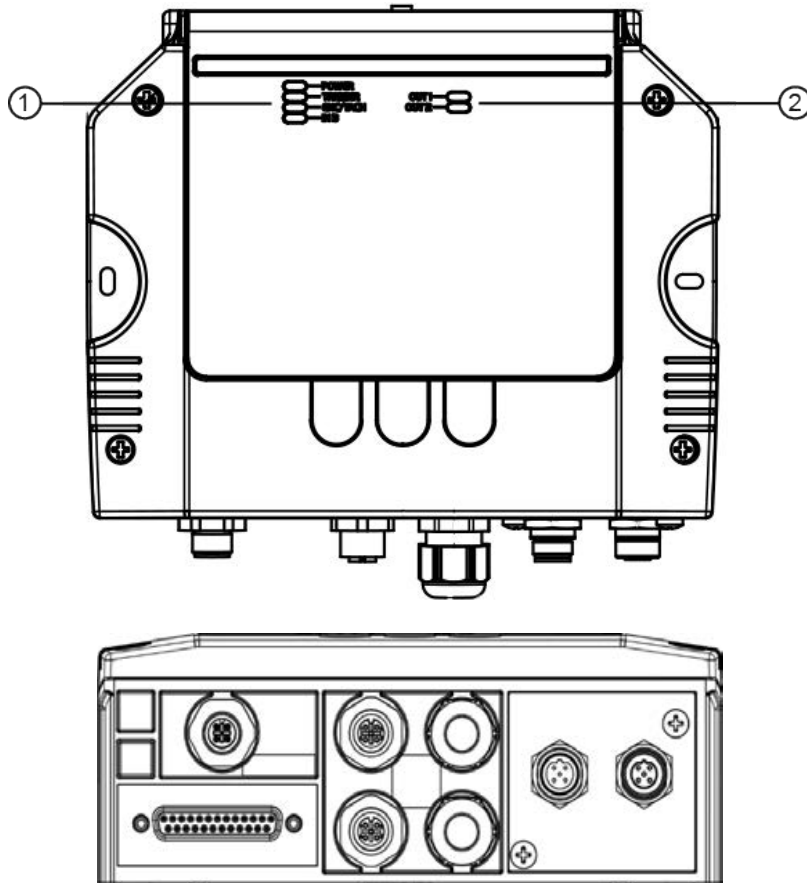

- ① POWER
TRIGGER
ENC/TACH
IN3
- ② OUT1
OUT2

Figure 6: MA 900 connection unit



NOTE: scanner operation requires an MA 900 connection unit or MSC 900 controller.

Industrial connection unit

MA 900 connection unit	MA 900 for BCL 900i	50129663
------------------------	---------------------	----------

1.10 MSC 900 SYSTEM CONTROLLER

The MSC 900 controller offers all the necessary functions to simplify the installation, setup, testing and maintenance of reading devices or tunnels for omnidirectional bar codes.

The MSC 900 controller is fully compatible with the BCL 900i scanner and its sturdy mechanical structure makes the MSC 900 controller the ideal solution for industrial environments. The controller enables connection to the trigger and encoder/rotation encoder. PNP inputs are available via M12 connectors on the lower front panel (see section 3.11).

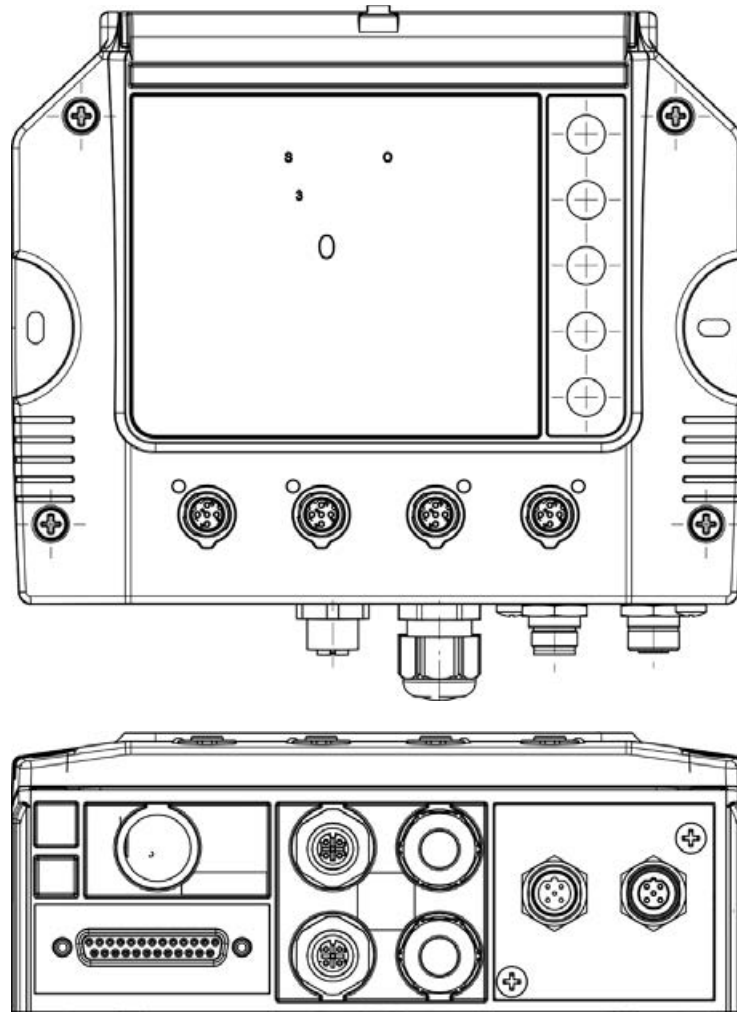

Figure 7: MSC 900 system controller

System controller

MSC 900 - 1000 system controller	Standard	50129664
MSC 900 - 1100 system controller	PROFIBUS	50129665
MSC 900 - 1200 system controller	PROFINET	50129666

2 MECHANICAL INSTALLATION



WARNING: Electrical installation must be performed by qualified service technicians only! Procedures can involve exposure to high voltage. They must therefore only be performed by trained and authorized technicians. Do not attempt to perform any electrical installation procedures unless you are a trained technician.



IMPORTANT: BCL 900i bar code scanners contain electronics that can be damaged by electrostatic discharge (ESD). To prevent personal injury or damage to the device, please follow the safety precautions and warnings found in the "References" section at the beginning of this manual. Failure to follow these precautions can void your warranty.

2.1 PREPARING FOR MECHANICAL INSTALLATION



IMPORTANT: application-specific drawings and documents provided by Leuze electronic supersede any contradictory content in this manual.

Before installing any components, please do the following:

- Read all instructions before starting installation.
- Define and confirm the correctness of the requirements for your application and for the position of the system, especially the height of the conveyor above the floor.
- Review all installation-specific drawings provided with your equipment.
- Review and plan the mechanical installation of all devices used in your application. Be sure to allow adequate clearance for maintenance.
- Review and plan the power requirements for your application.
- Check the contents of the shipping cartons against the delivery note.
- Note down all product serial numbers.



NOTE: refer to **Chapter 3, *Electrical installation*** and the reference documentation for details on connecting your bar code scanners to other devices in the system.



WARNING: when installing several scanners, take care to position them so that no laser beam enters the reading window of other scanners. This can occur more frequently in applications with side-mounted devices. Failure to follow these precautions can have a negative effect on the read rate. To resolve this problem, it is sufficient to slightly change the pitch and position of one of the two scanners involved if possible.

2.2 UNPACKING INSTRUCTIONS

Make sure that the BCL 900i bar code scanners and all the parts supplied with the device are present and intact when opening the packaging. The list of parts includes:

- BCL 900i reader
- BT 900 mounting bracket
- Mounting screws (two types) and washers
- BCL 900i info sheet with bar code sample inside

2.3 INSTALLATION SEQUENCE



NOTE: all components should be MECHANICALLY INSTALLED before ELECTRICAL INSTALLATION is started.
See Chapter 3, Electrical installation, for details on electrical installation.

To carry out mechanical installation and setup, you must perform the following:

- Check the details concerning the requirements of your application
- Erect the mounting structure or other supporting structures
- Determine and mark the mounting bracket location(s)
- Mount the mounting bracket to the mounting structure
- Mount the BCL 900i to its mounting bracket
- Mount the photoelectric sensor to the mounting structure (optional)
- Mount the rotation encoder to the mounting structure (optional).
- Mount the MA connection unit to the mounting structure
- Mount the MSC 900 to the mounting structure, if necessary
- Carry out electrical installation (*see Chapter 3*).
- Align the BCL 900i so that it functions properly
- Configure the BCL 900i (*see Chapter 4*).
- Check the functions of the BCL 900i (*see Chapter 5*).

2.4 WHAT YOU NEED TO KNOW ABOUT YOUR APPLICATION

To ensure that your BCL 900i delivers optimum performance, the device must be installed such that all the requirements of your application are met. Therefore, take some time to familiarize yourself with the details of your application. The better you know your application, the easier it is to utilize the capabilities of the BCL 900i to meet the requirements of your application.

Below is what you will need to know before you can begin installation:

- Conveyor specifications
 - Conveyor type: Belt, tilt-tray, cross belt, other?
 - How wide is the conveyor?
 - How fast is the conveyor?
 - Does the conveyor speed vary or is it constant?
- Product specifications
 - Are the packages being transported always singulated (not touching) or non-singulated (possibly touching)?
 - How many different product sizes may be involved?
 - Are products justified: toward/away from reader, centered, or variable?
- Application specifications
 - How is the bar code information processed in your application?
 - What are your communication requirements?

While it is nearly impossible to cover all application configurations, the following pages provide basic information to help you decide how to mechanically install your BCL 900i. If you need additional assistance, please contact your sales representative or customer service (www.leuze.com).

2.5 INSTALLATION

2.5.1 Dimensions and clearances

The overall dimensions of the BCL 900i are 216 x 96 x 127 mm [8.5 x 3.8 x 5 in].

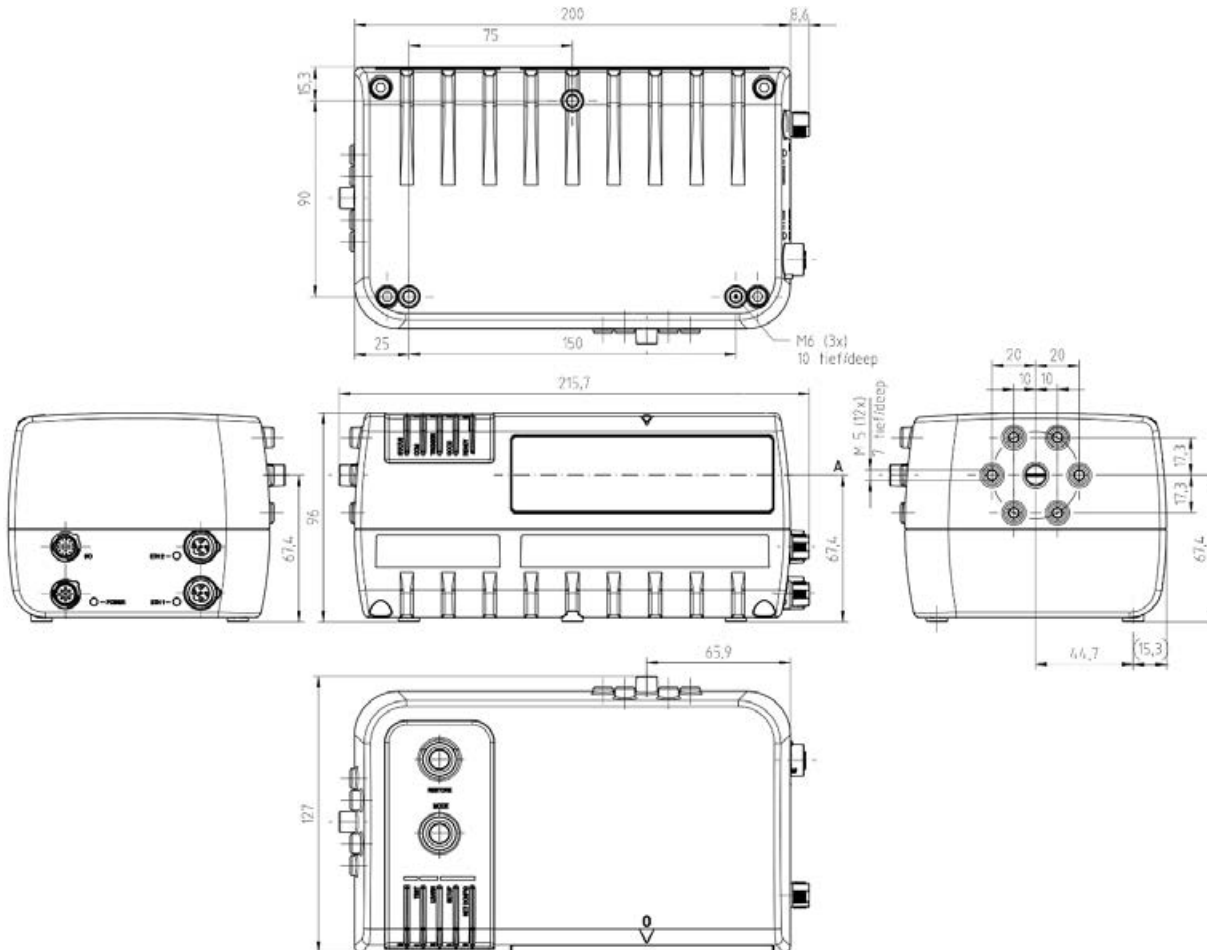

IMPORTANT: the BCL 900i is a sealed, unventilated device. Mounting the device with 300 mm [12"] of clearance (front, top and sides) is recommended for cooling and ease of maintenance.

2.5.2 Requirements regarding load-bearing capacity

For details on the weight of the bar code scanner, see *Chapter 8, Technical features*. For multiple-head systems, further details on load-bearing requirements may apply, for which application-specific documentation is provided.

2.5.3 Operational restrictions in the case of vibration

See *Chapter 8, Technical features*.

2.5.4 General mounting guidelines

It is important that you follow these general precautions when installing, setting up, operating, maintaining, troubleshooting or replacing any Leuze electronic products, parts or related equipment.

As you plan and install your BCL 900i bar code scanning system application, be sure to observe the following guidelines:

- Installation of the mounting structure and the device can be performed by one installer.
- Determine the correct orientation and position of the bar code scanner.
- Leave adequate clearance (approx. 300 mm [12 inches]) for wiring.
- Route cables carefully to reduce or minimize electrical interference. In cases where it is not possible to avoid power and communication cables from crossing, make sure that they cross each other perpendicularly.
- Proper grounding limits the effects of noise due to electromagnetic interference (EMI).

2.5.5 Considerations regarding mounting structure

Your first task is to mount your BCL 900i bar code scanner.

Your mounting structure must provide the following capabilities:

- It is adjustable enough for you to move your device to the optimum position for proper scanning.
- It allows a technician access to the bar code scanner while it is mounted.
- It must be as vibration free as possible so as not to affect scanning accuracy.
- It is constructed of steel or aluminum.
- It provides clearance of 300 mm [12 inches] on all sides. This clearance is necessary to ensure proper ventilation, allow access to all housing panels of the bar code scanner and provide adequate space for maintenance.

2.5.6 Mounting the scanner

The BCL 900i can be installed to operate in any position. There are 12 screw holes (M6 X 8) on the sides of the scanner for mounting. The figure below can be used for installation; refer to the reading diagrams (see 5.10) and any application drawings for correct positioning of the scanner with respect to the reading zone and for the scanner orientation.

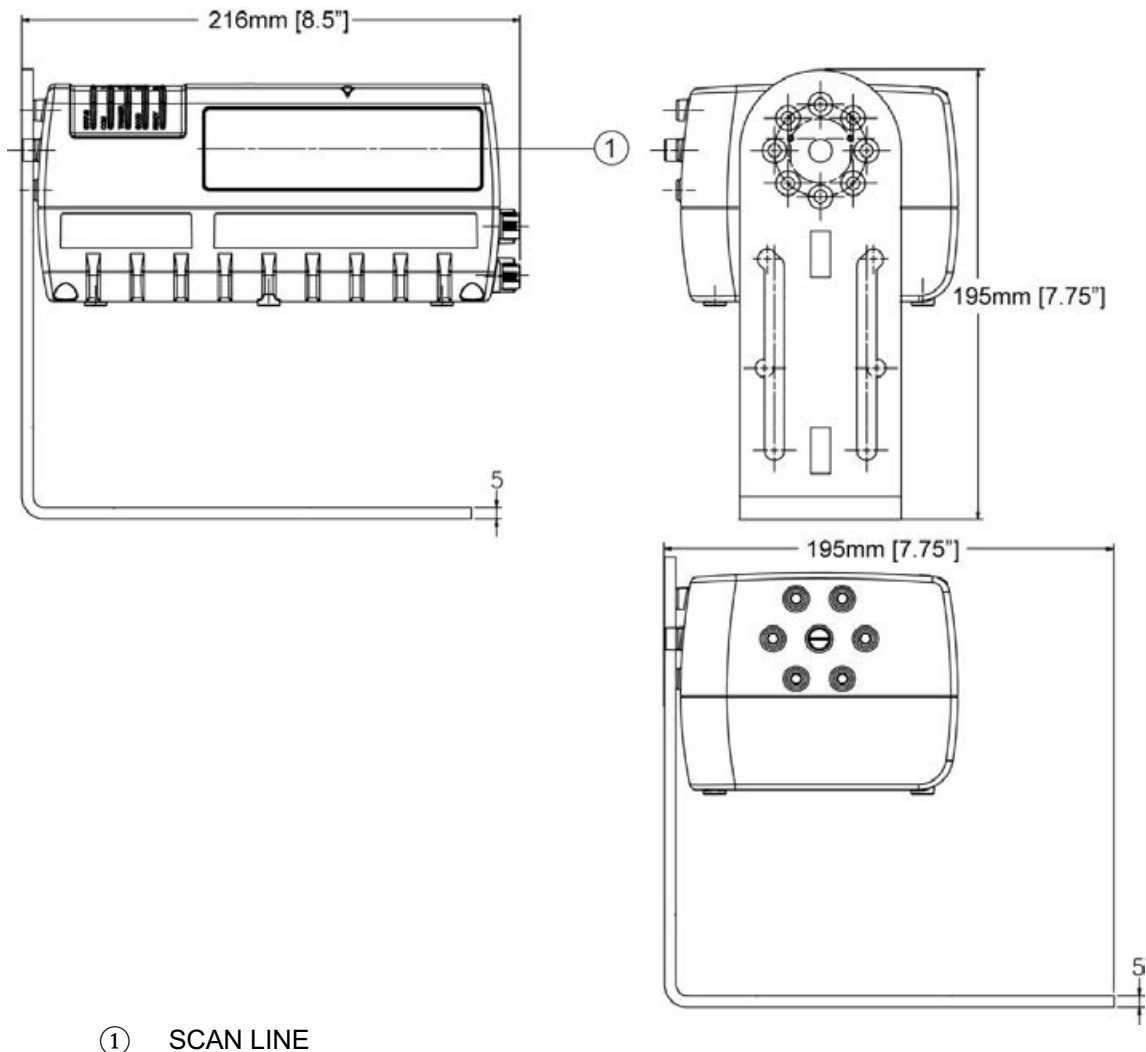
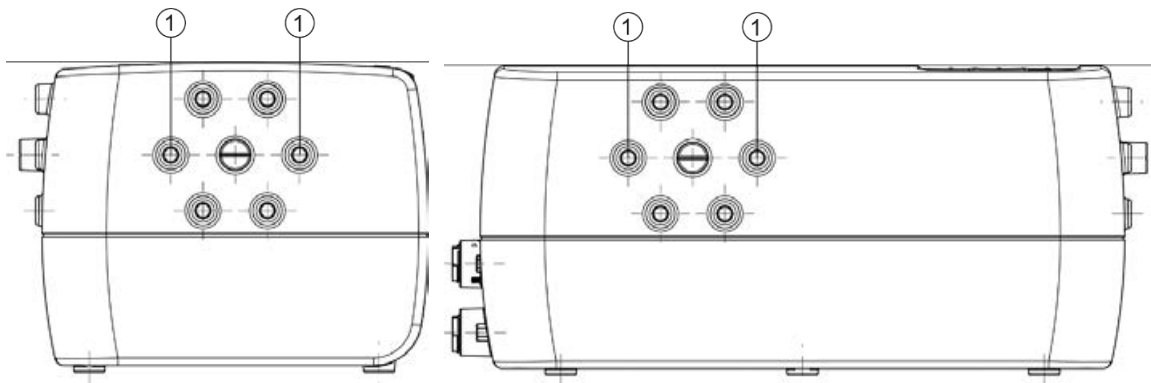

Figure 8: Mounting dimensions of BCL 900i with BT 900

The BT 900 included with the BCL 900i scanner allows the device to be installed in the most suitable position for your application. The BT 900 is mounted to the scanner as shown below:



① Mounting position

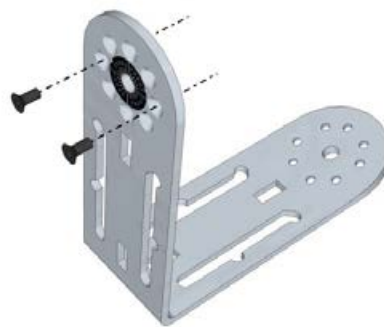

Figure 9: Assembly of BCL 900i and BT 900 using countersunk screws

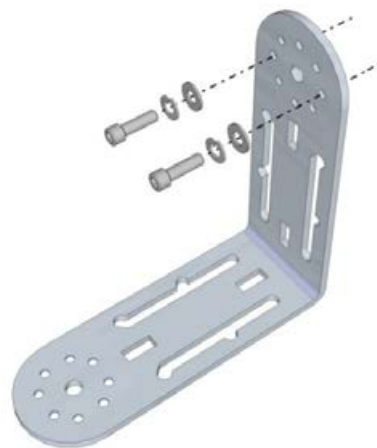

Figure10: Assembly of BCL 900i and BT 900 using head screws, lock washers and flat washers

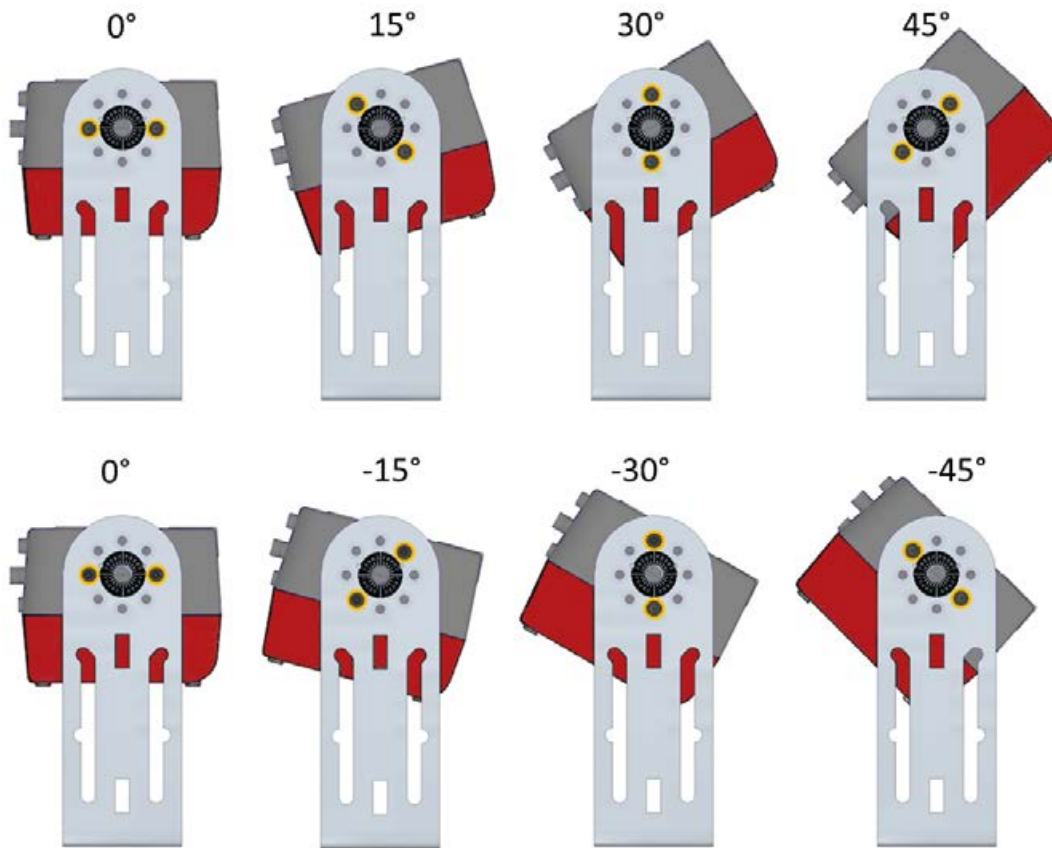

Figure 11: Mounting brackets of BCL 900i

If the BCL 900i needs to be mounted at a 5-degree angle or within 5-degrees of the angles shown in **Figure 11: Mounting brackets of BCL 900i** (+/- 5, +/- 25 or +/- 35 degrees), mount it to the opposite end of the BT 900 as shown below:

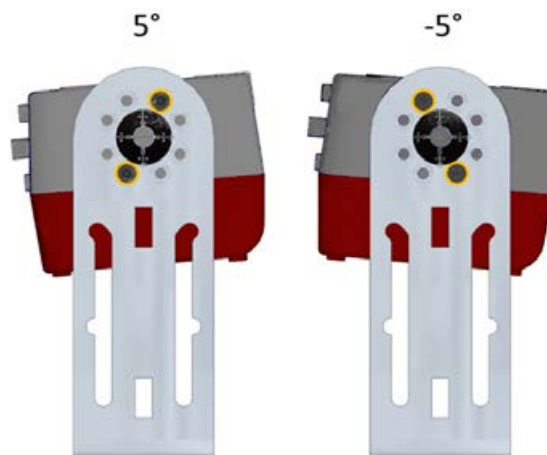

Figure 12: 5-degree mounting option for BCL 900i

2.5.7 Positioning the scanner

The BCL 900i bar code scanners are able to decode bar code labels at a variety of angles; however significant angular distortion may degrade reading performance.

When mounting the scanner, take into consideration these three ideal label position angles: pitch 0°, skew 0° and tilt 0°.

Follow the suggestions to determine the best orientation:



- α Azimuth angle (tilt)
- β Pitch
- γ Angle of rotation (skew)

Figure 13: Azimuth angle, pitch and skew

3 ELECTRICAL INSTALLATION



WARNING: electrical installation must be performed by qualified service technicians only! Procedures can involve exposure to high voltage. They must therefore only be performed by trained and authorized technicians. Do not attempt to perform any electrical installation procedures unless you are a trained technician.



IMPORTANT: BCL 900i bar code scanners contain electronics that can be damaged by electrostatic discharge (ESD). To prevent personal injury or damage to the device, please follow the safety precautions and warnings found in the "References" section at the beginning of this manual. Failure to follow these precautions can void your warranty.

3.1 PREPARING FOR ELECTRICAL INSTALLATION

Before installing any components, please do the following:

- Read all instructions before starting installation.
- Observe all electrical safety requirements discussed in the introduction of this manual.
- Define and confirm the correctness of the requirements for your application.
- Review all installation-specific drawings.
- Review and plan the power requirements for your application.
- Review and plan the communication requirements for your application.



IMPORTANT: the content of this manual may be superseded by any customer-specific documentation provided by Leuze electronic. Before proceeding with any installation procedures, be sure to review ALL documentation, especially content that contains details specific to your installation.



NOTE: all components should be **MECHANICALLY INSTALLED** before performing any **ELECTRICAL INSTALLATION**. See Chapter 2 for details on mechanical installation.

Most BCL 900i applications are shipped with the MA connection unit and all the necessary wiring required to electrically install the system. If your system requires custom-length cables or other special wiring, documentation specific to these requirements has been provided in your shipment. This special documentation supersedes any contradictory content in this manual.



NOTE: to reduce the possibility of damage to the device, check that all wiring between the scanner and other devices is correct.

3.2 CONNECTING A BCL 900i SCANNER

To install a BCL 900i bar code scanner, follow this sequence:

- Carry out mechanical installation (*see Chapter 2*).
- Carry out electrical installation (*see the wiring illustrations provided in this chapter*).
- Observe all electrical safety requirements outlined in this chapter.
- Ground the mounting structure by connecting it to protective conductor (PE).
- If used, connect the photoelectric sensor (or other trigger) to the MA 900 connection unit or MSC 900.
- Connect the rotation encoder to the MA 900 connection unit or MSC 900 (if used).
- Connect serial ports to the MA 900 connection unit or MSC 900 if needed.
- Connect the M12 end of the Ethernet cable to the scanner's HOST port and the network switch as required by your application.
- Connect the scanner to its power supply unit.
- Connect the power supply unit to the power source.
- Set up/check scanner operation (*see Chapter 5*).

3.3 TYPICAL CONNECTION BLOCK DIAGRAMS

3.3.1 Connection of a single BCL 900i bar code scanner to MA 900

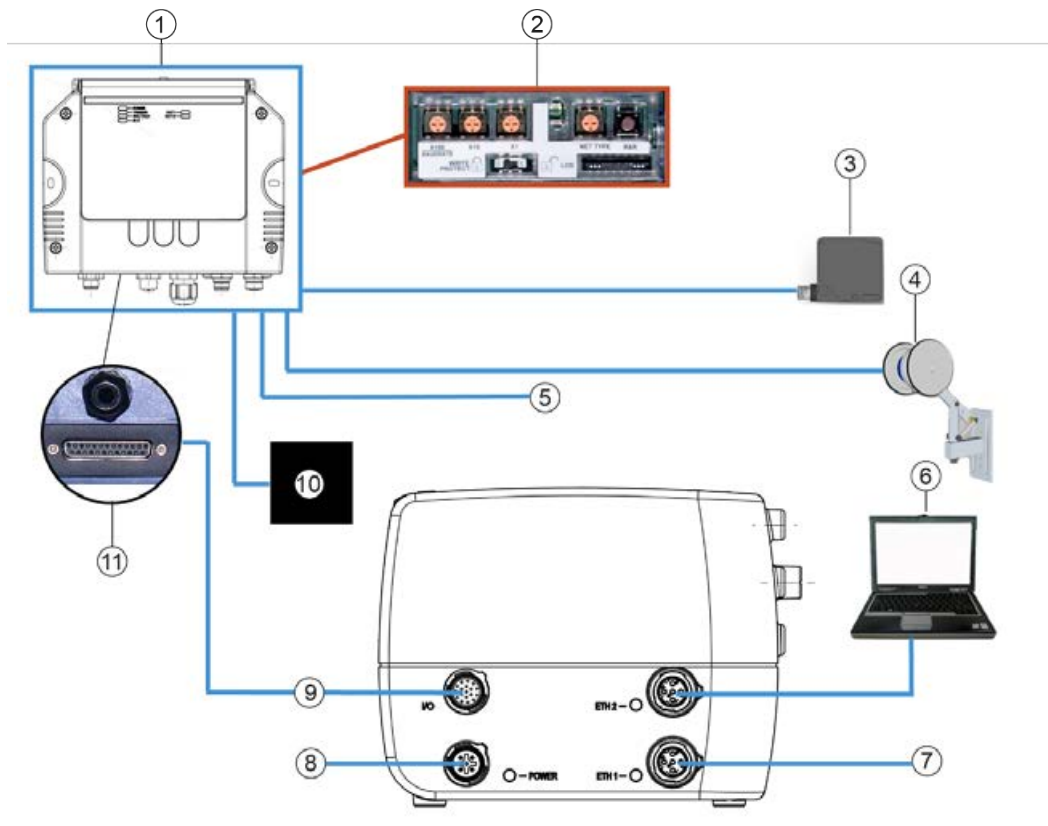

- ① MA 900
- ② Backup module
- ③ Photoelectric sensor
- ④ Encoder/rotation encoder
- ⑤ Digital output(s)
- ⑥ Setup PC
- ⑦ Host
- ⑧ PWR
- ⑨ 17-pin M12 connector
- ⑩ RS232 or RS422FD host
- ⑪ 25-pin D connector

Figure 14: Connection of single BCL 900i to MA 900

3.3.3 BCL 900i bar code scanners in an array with MSC 900 master

In an array (tunnel) where the MSC 900 controller is used, the scanner chain forms a loop from and to the MSC 900 controller via ETH1 and ETH2. In this scenario, if one scanner fails, data transmission from the other scanners to the MSC 900 controller is not interrupted.

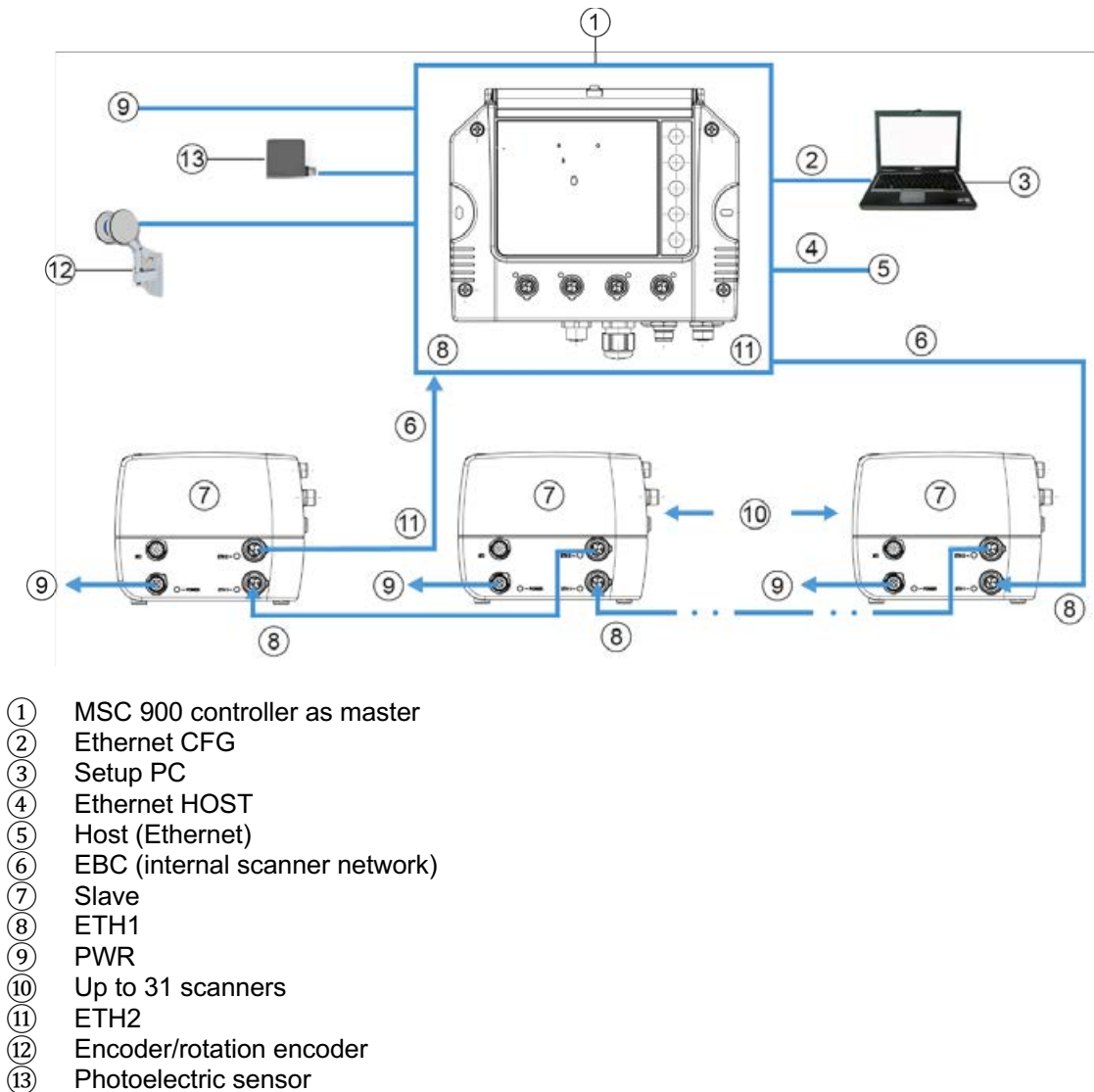
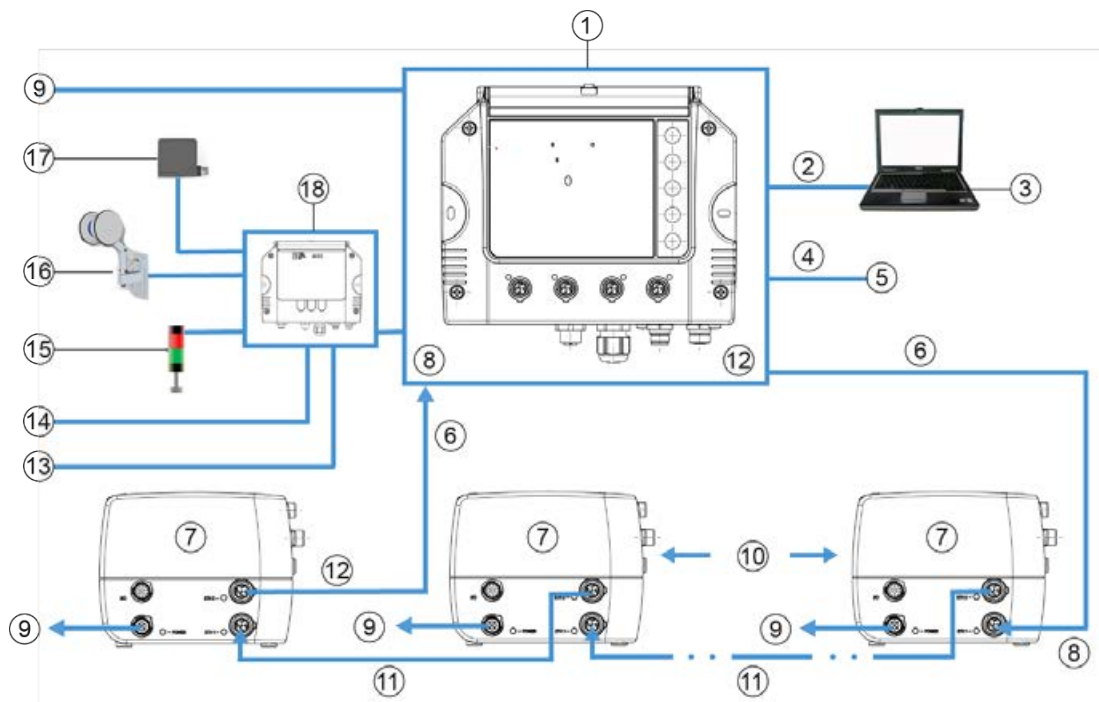

Figure 16: BCL 900i array (tunnel) with MSC 900



- ① MSC 900 controller as master
- ② Ethernet CFG
- ③ Setup PC
- ④ Ethernet HOST
- ⑤ Host (Ethernet)
- ⑥ EBC
- ⑦ Slave
- ⑧ ETH1
- ⑨ PWR
- ⑩ Up to 31 scanners
- ⑪ Ethernet
- ⑫ ETH2
- ⑬ Host (fieldbus)
- ⑭ Host (serial)
- ⑮ Signaling column or diverter
- ⑯ Encoder/rotation encoder
- ⑰ Photoelectric sensor
- ⑱ MA 900

Figure 17: Connection of BCL 900i array (tunnel) to MSC 900 (alternatively with MA 900)

3.4 GENERAL GUIDELINES AND PRECAUTIONS FOR ELECTRICAL INSTALLATION

It is important that you follow these general precautions when installing, setting up, operating, maintaining, troubleshooting or replacing any Leuze electronic products, parts or related equipment. As you plan and install your scanner(s), be sure to observe the following guidelines:

- Make sure that the scanner is at the correct position as outlined in Chapter 2.
- Leave adequate clearance (approx. 300 mm [12 inches]) for wiring.
- Route cables carefully to reduce or minimize electrical interference.



IMPORTANT: when planning your installation wiring, remember that all power connections must be of the quick-disconnect type. For **PERMANENTLY CONNECTED DEVICES**, a readily accessible disconnect device must be incorporated in the building installation wiring. For **PLUGGABLE DEVICES**, the power socket must be installed close to the device and must be easily accessible.



WARNING: to ensure that no ESD damage will occur, be sure to observe the precautions outlined in the introduction of this manual.



IMPORTANT: ground the mounting structure by connecting to the protective conductor (PE). For information on the protective conductor, see the wiring recommendations.

3.5 BCL 900i, CONNECTION FIELDS

After completing mechanical installation, use this section to properly wire your scanners for optimal performance in your application. With the BCL 900i, cables are routed to the connection field and to the MA connection unit (connected to the I/O port of the scanner). In most applications, the scanner has the following cable connections:

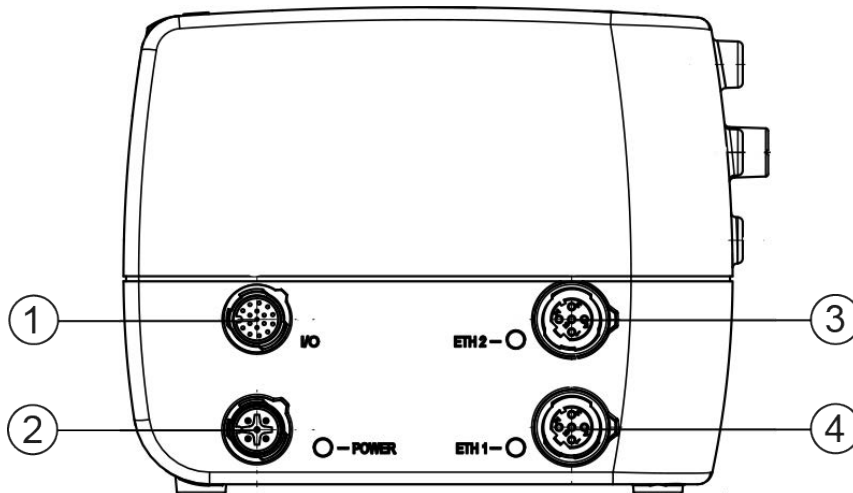

- ① I/O (direct connection to the 25-pin D-type connector on the MA connection unit)
- ② POWER
- ③ ETH 2 (setup or EBC scanner network)
- ④ ETH 1 (host or EBC scanner network)

Figure 18: BCL 900i connection field

If you want to connect cables to other devices, route the cables from the scanner's connection field through the cable ducts (if available) of the mounting structure from Leuze electronic.

3.6 CONNECTING A PC TO THE BCL 900i

During initial setup, a PC (laptop) can be connected to the BCL 900i with a M12-to-RJ45 cable. Screw the M12 connector to the ETH 2 port of the scanner and plug the RJ45 connector into the Ethernet port of your PC. If the ETH 2 port is already being used, the ETH 1 port can be used instead. For information on connection to the user interface, see *Chapter 4*.



NOTE: ETH2 is the **setup** port; ETH1 is the **HOST** port.



NOTE: a laptop can only communicate to a scanner that is connected to an MA connection unit or MSC 900 controller.



NOTE: parameters for tunnels are set up in a MASTER scanner (or MSC 900 controller) only.

3.7 TABLE SHOWING PIN ASSIGNMENT OF POWER SUPPLY CONNECTOR

A recommended power supply and wiring are available for the BCL 900i (and MSC 900 controller). However, if your installation requires customer-specific power supply wiring, the pin assignment of the power supply device connector is given below.

24V - - - 4A MAX		Power supply input	
		Device connector (see figure)	Mating cable connector
		M12 connector, 5-pin	M12 socket, 5-pin
M12 connector, 5-pin 	Pin	Function	
	1	+24 VDC	
	2	n/c	
	3	Functional earth	
	4	n/c	
	5	Protective conductor (housing ground)	



NOTE: when using a BCL 900i bar code scanner, no power supply is required for the MA 900 connection unit. All power supply connections and some data transmission connections are fed to the MA 900 through the scanner's 17-pin I/O connector to the 25-pin connector of the MA 900 using the cable provided.

3.8 POWER SUPPLY CONNECTIONS



IMPORTANT: when planning your installation wiring, remember that all power connections must be of the quick-disconnect type.



CAUTION: when performing the following wiring connection procedures, be sure to follow all safety procedures regarding high voltage as outlined in the introduction to this manual. No voltage should be applied to any device until all wiring is completed and checked for correctness.



IMPORTANT: the power socket must be installed close to the scanner. The power socket must be a readily accessible disconnect device.



GROUND: ground the scanner by connecting to the protective conductor (PE). For information on the protective conductor, see the wiring recommendations.

The MA connection units provide flexible options for networking a wide range of I/O devices as well as for serial hosting. The BCL 900i is connected to the MA via its I/O port using a single cable with a 17-pin M12 connector at one end and a 25-pin D connector at the other. The MA connection unit also provides space for an optional backup module (recommended) for parameter storage, allowing quick replacement and configuration of the scanners.

In a system with multiple scanners and other devices required in a scanning array (tunnel), an MSC 900 controller serves as the system master and manages data exchange between the devices and the host. Complete installation information for the MSC 900 controller is available in the **MSC 900 system controller reference manual** available at www.leuze.com.

3.9 MA 900 CONNECTION UNIT

Complete installation information for the connection unit is available in the *MA 900 installation manual* available at www.leuze.com. A simple drawing of the interior of the box is shown below.

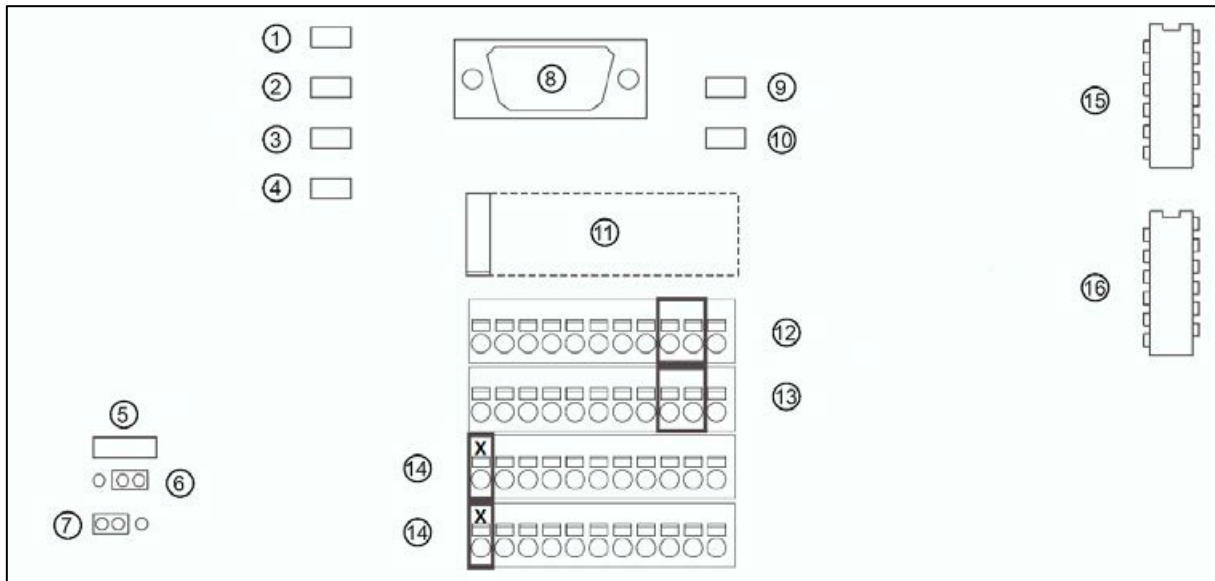

- ① POWER
- ② TRIGGER
- ③ ENC/TACH
- ④ IN3
- ⑤ DEVICE GROUND
- ⑥ Earth
- ⑦ GND
- ⑧ AUX
- ⑨ OUT1
- ⑩ OUT2
- ⑪ BACKUP/RESTORE MODULE
- ⑫ IO4 +/- RESERVED FOR MSC 900
- ⑬ O3 +/- RESERVED FOR MSC 900
- ⑭ RESERVED
- ⑮ FIELDBUS BOARD IP65
- ⑯ FIELDBUS BOARD STD

Figure 19: MA 900 interior

3.9.1 Supply lines to MA 900 connection unit



WARNING: DO NOT connect a separate power source to the MA 900 connection unit. The MA 900 receives its operating voltage through its interconnection cable to the BCL 900i bar code scanner. Connecting a separate power source will be detrimental to system operation.



IMPORTANT: DISCONNECT THE POWER SUPPLY LINE from the scanning system and MA 900 before wiring any components.

Loosely laid cables must pass through the water-tight cable glands in the base of the MA 900 connection unit. Insert the cables allowing enough slack for the individual wires to reach the appropriate terminal block connectors. Securely tighten the water-tight cable glands after the cables have been inserted.

Insulation on individual wires should be removed to expose 13 mm [0.5 inch] of bare metal before inserting into the terminal block.

3.10 PHOTOELECTRIC SENSOR CONNECTIONS TO MA 900

Bar code scanning applications can use a Leuze electronic photoelectric sensor as a trigger device. The photoelectric sensor is connected directly to the terminal in the MA 900.

If your application uses a trigger other than the one specified by Leuze electronic, follow the appropriate wiring diagram to ensure correct connection.



NOTE: to confirm that the photoelectric sensor is functioning properly, watch the TRIG LED while the photoelectric sensor beam is blocked. The Leuze electronic photoelectric sensor also includes a status LED.

The following diagrams illustrate the recommended standard wiring of the photoelectric sensor to the MA 900 terminal block.

3.10.1 Photoelectric sensor (NPN)

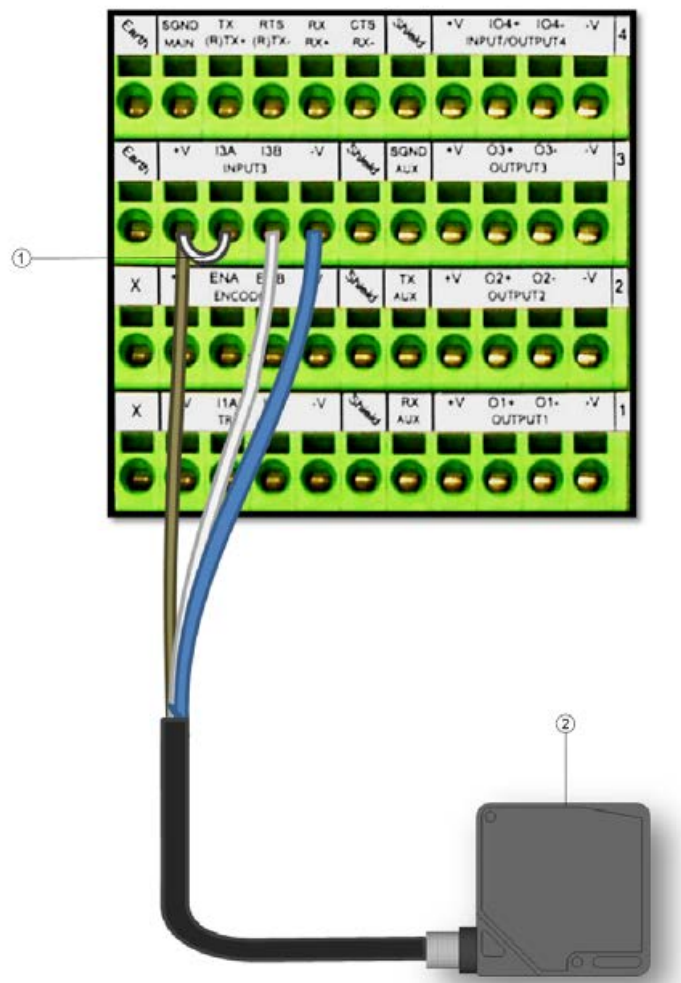

- ① Jumper
- ② Photoelectric sensor

Figure 20: Wiring of photoelectric sensor (NPN output)

3.10.2 Photoelectric sensor (PNP)

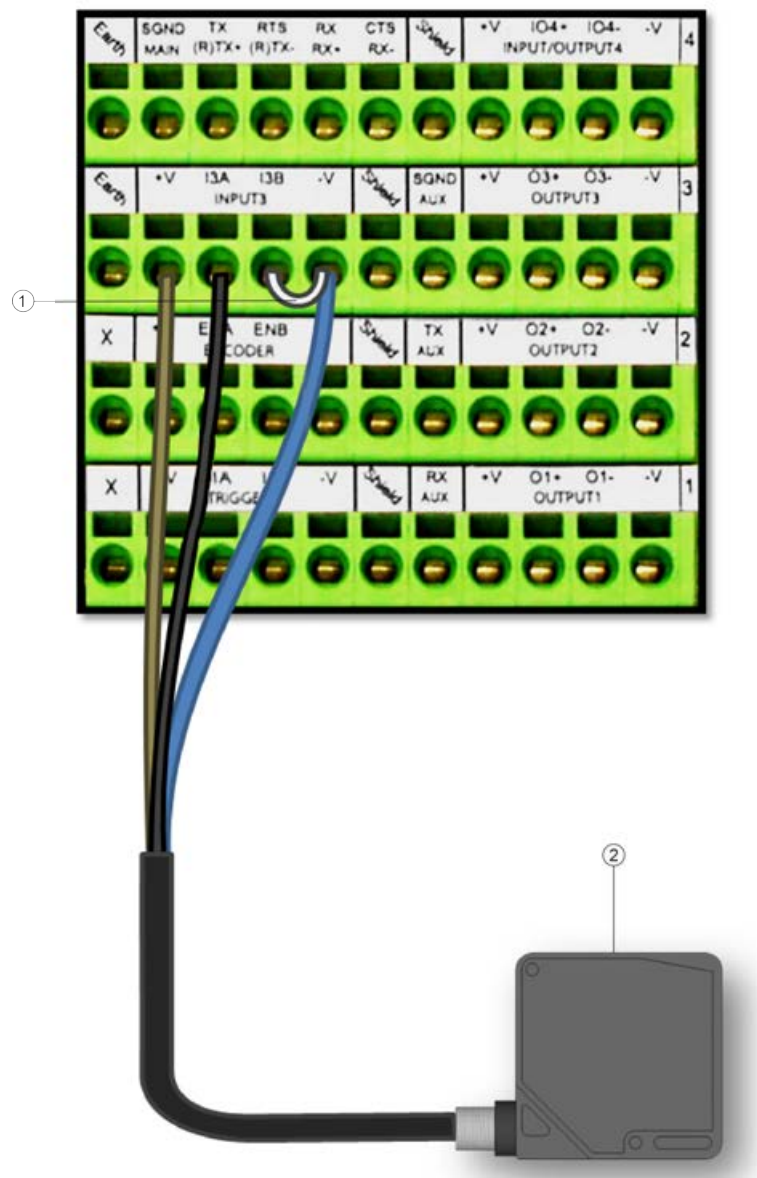

- ① Jumper
- ② Photoelectric sensor

Figure 21: Wiring of photoelectric sensor (PNP output)

3.11 CONNECTING ROTATION ENCODER TO MA 900

Omni applications above a conveyor belt use an accessory rotation encoder and mounting kit. The following diagrams illustrate the recommended standard wiring of an encoder to the MA 900 terminal block.

3.11.1 Encoder/rotation encoder wiring for NPN output (two models)

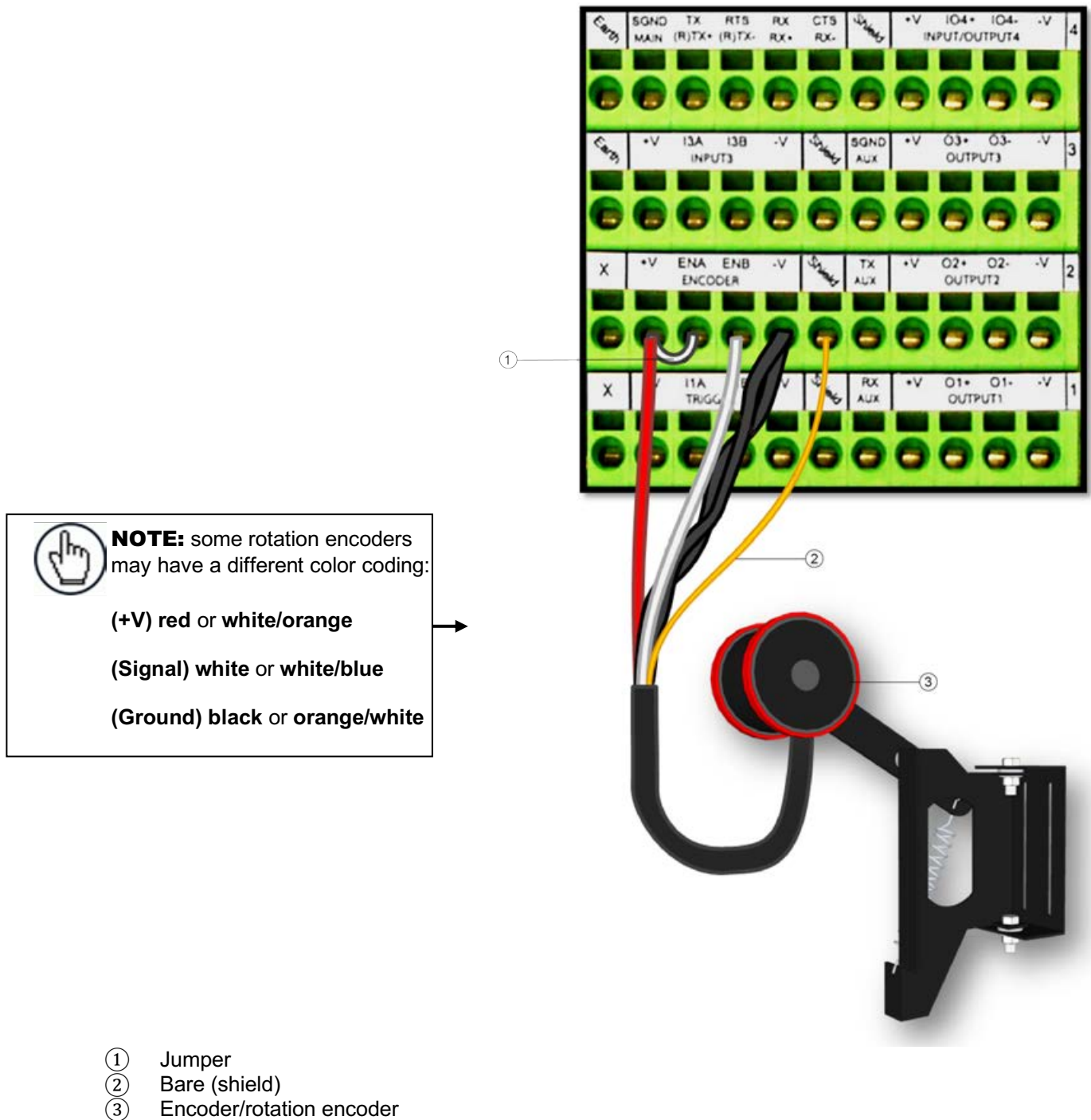
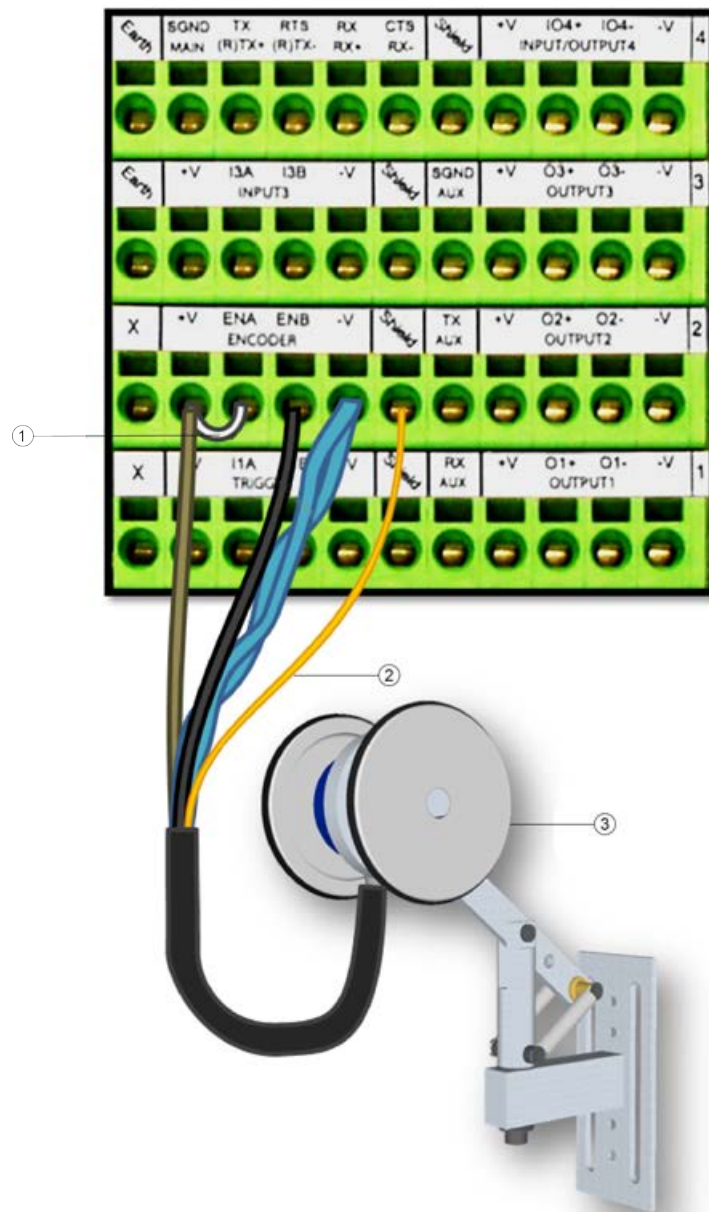

Figure 22: Encoder/rotation encoder wiring (NPN output)



- ① Jumper
- ② Bare (shield)
- ③ Encoder/rotation encoder

Figure 23: Encoder/rotation encoder wiring (NPN output)

3.11.2 Encoder/rotation encoder wiring for PNP output (two models)

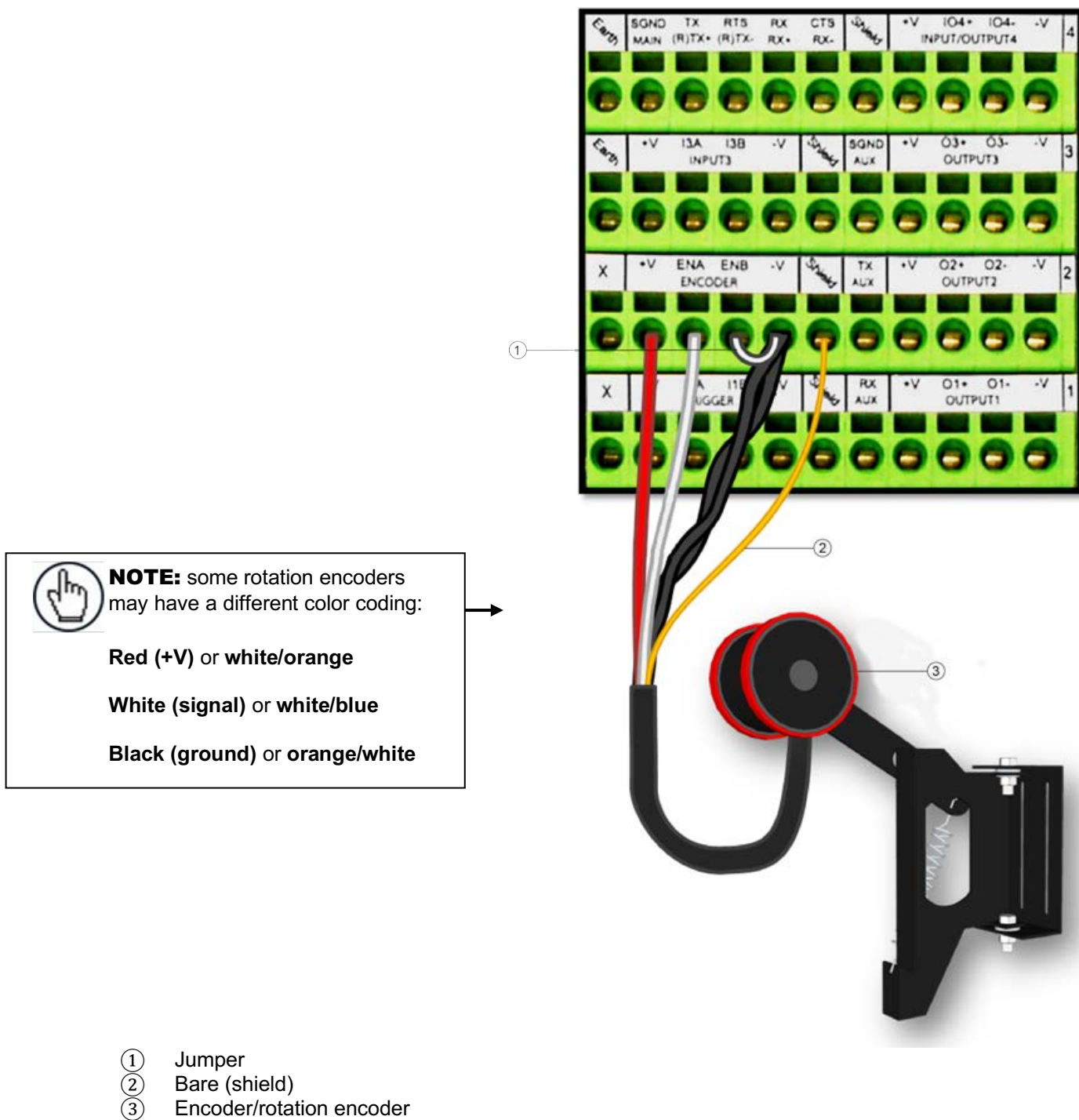
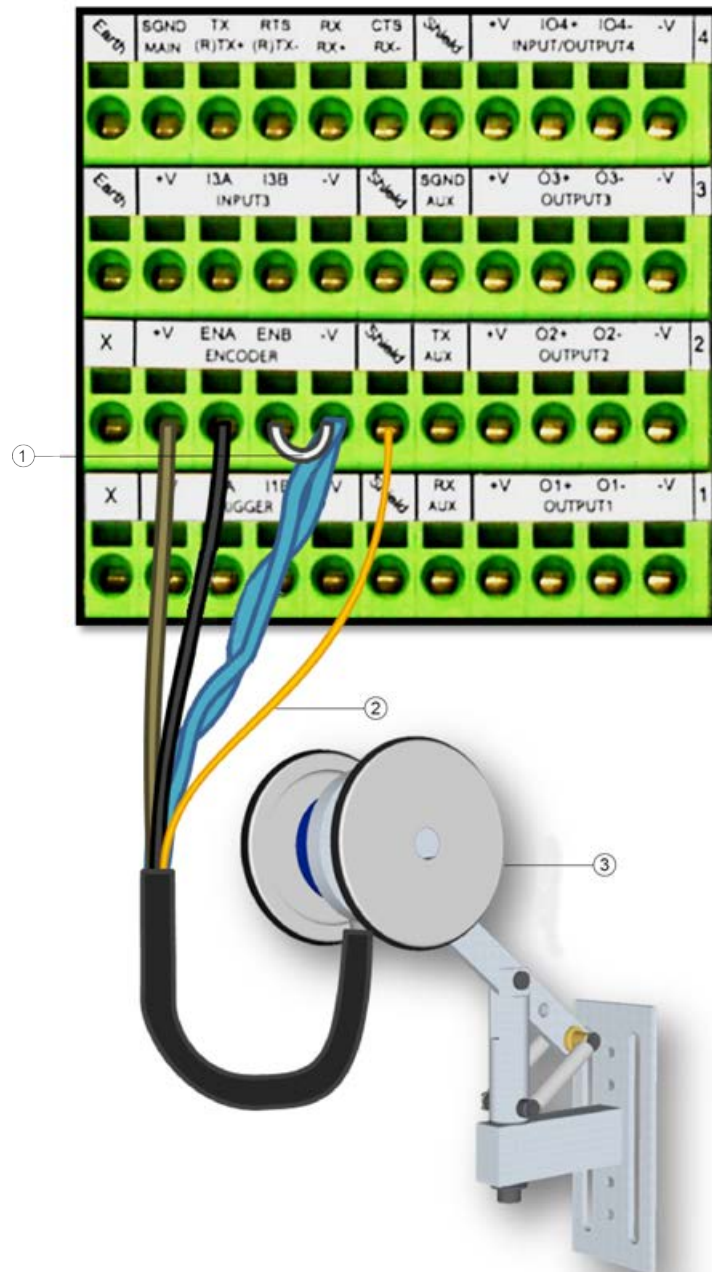

Figure 24: Encoder/rotation encoder wiring (PNP output)



- ① Jumper
- ② Bare (shield)
- ③ Encoder/rotation encoder

Figure 25: Encoder/rotation encoder wiring (PNP output)

3.12 DIGITAL OUTPUT CONFIGURATION TO MA 900

The MA 900 includes an OUTPUTS terminal block for connecting relays, which can be used as external accessories depending on requirements. The **Modify settings | Digital I/O** user interface window includes options for outputs 1 and 2 with **Primary** and **Secondary activation event** options including **Complete read**, **Partial read**, **No read**, **Trigger On**, **Trigger Off**, **Multiple read**, **Right/match** and **Wrong/no match**.

Schematics for digital outputs with electrical isolation and without electrical isolation are provided below.

Outputs 1 - 3
Maximum voltage 30 V
Collector current (pulse) 130 mA max.
Collector current (continuous) 40 mA max.
Saturation voltage (VCE) 1 V at 10 mA max.
Maximum power dissipation 90 mW at 50°C (ambient temperature)

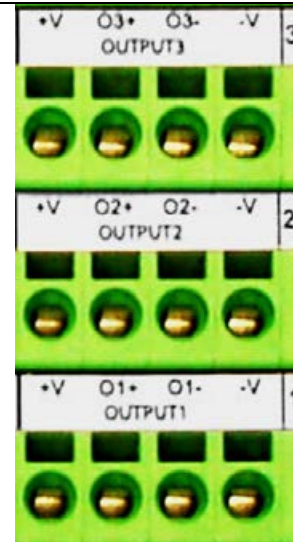

Figure 26: OUTPUTS terminal block

3.12.1 Unpowered outputs

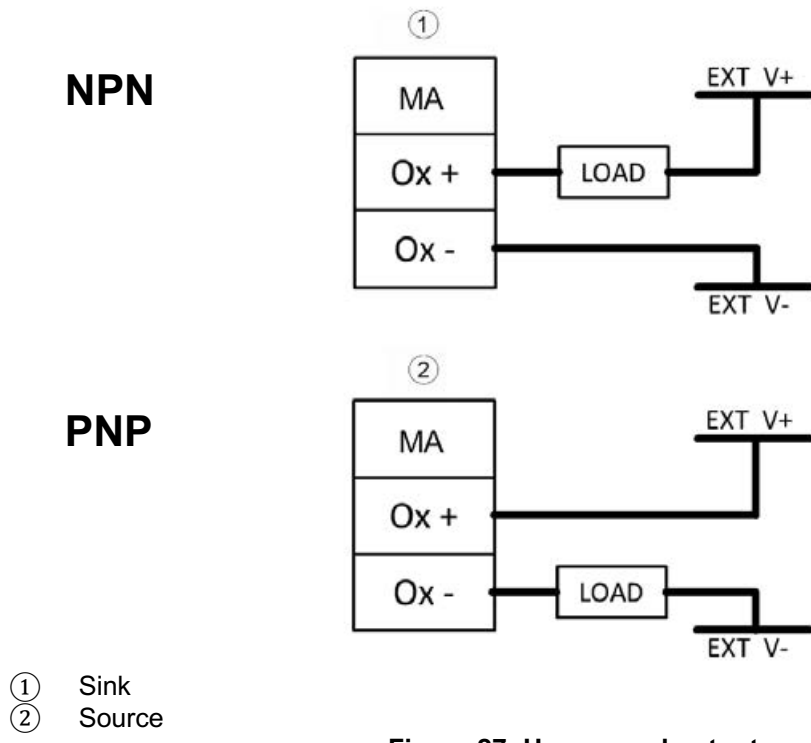
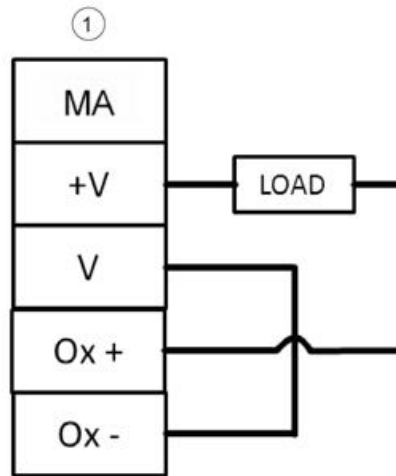

Figure 27: Unpowered outputs

3.12.2 Powered outputs

NPN



PNP

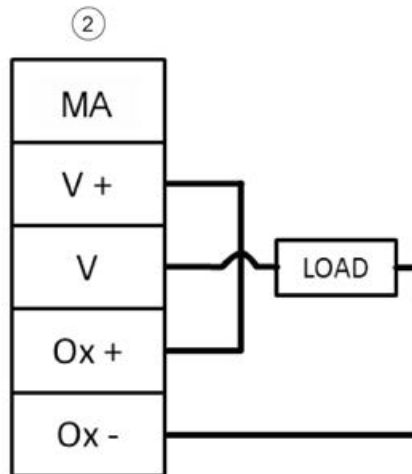

- ① Sink
- ② Source

Figure 28: Powered outputs

3.13 CONNECTING TO MSC 900 SYSTEM CONTROLLER (OPTIONAL)

In larger scanning arrays (scanning tunnels), an MSC 900 controller can act as the system master and support up to 31 BCL 900i slave bar code scanners in an Ethernet-based connection loop (EBC). MSC 900 cable connections are made at the front and bottom connection fields. In most applications, the scanner has the following cable connections:

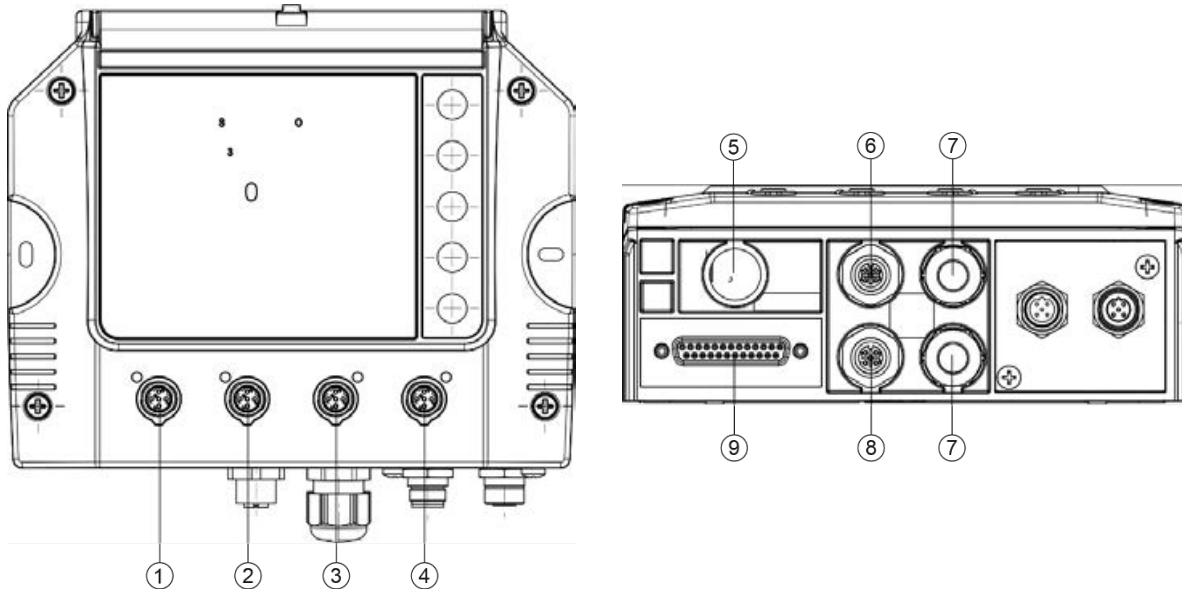

- ① CFG (configuration via laptop Ethernet cable)
- ② HOST
- ③ ETH 1 (EBC scanner network)
- ④ ETH 2 (EBC scanner network)
- ⑤ POWER
- ⑥ ENC (PNP encoder/rotation encoder)
- ⑦ Water-tight connectors
- ⑧ TRG (PNP trigger/photoelectric sensor)
- ⑨ I/O (direct connection to the 25-pin D-type connector on the MA connection unit)

Figure 29: Connectors in bottom panel of MSC 900

Complete installation information for the MSC 900 controller is available in the **MSC 900 system controller reference manual** available at www.leuze.com.

3.14 CHECKING SCANNER INSTALLATION

After completing the installation of your bar code scanner, make sure that the bar code scanners, MA connection unit and/or MSC 900 controller have been properly installed mechanically and electrically. Use the installation sequence at the beginning of this chapter and your application specifications to check your installation.

4 USER INTERFACE

4.1 GETTING STARTED

The **BCL 900i** bar code scanners are designed for ease-of-setup. The **BCL 900i user interface** is a browser-based application for defining operating parameters, monitoring read quality, creating output messages and viewing diagnostics functions. The user interface enables you to easily configure, fine-tune and monitor operation of your scanner.

This user interface is easy to use on all user levels.

4.1.1 Requirements

Before setting up your bar code scanner, you will need the following:

Computer	Laptop
Browser	Internet Explorer 11 (or later) Firefox 30 (or later) Chrome 36 (or later)
Java	Java version 8 (or later)



NOTE: if the Diagnostics | Monitor page does not run, you may need to create an exception in the Java Control Panel.

Proceed as follows:

If the Diagnostics | Monitor page does not run, you may need to create an exception in the Java Control Panel.

Proceed as follows:

1. Click the **Start/Home** button and type **Configure Java** in the search field. Select the **Java control panel** from the search results. The **Java control panel** opens.
 2. Click the **Security tab** to open it.
 3. Under **Exception list**, click **Edit site list...** The **Exception list** window opens.
 4. Click **Add**.
 5. Enter the IP address for the system/scanner in the field provided as follows: `http://10.27.154.125/` (but matching your system's IP Address)
 6. Click **OK**. The Monitor page should now load.
-

4.1.2 Starting the user interface

To access the user interface:



NOTE: before starting up or testing the scanner, it must be connected to an **MA 900 connection unit** (see section 3.9.1) or an **MSC 900 controller** (see section 3.13) depending on the system configuration.

1. Connect your computer to the scanner's ETH 2 port using the KB ET-xxxx RJ45 ETHERNET CABLE or M12-TO-RJ45F cable. If the ETH 2 port is already being used, ETH 1 can be used instead.
2. Turn on your computer.
3. If you are connecting to a stand-alone unit (not connected to an in-house network), you must configure your PC's IP Address to be in the same network as the scanner's (or if used, controller's) IP address.

To change your PC's IP address:

- a. From the desktop, click the **Start** button and then select **System control**.
- b. Type **adapter** in the search box and then from the results, under **Network and sharing center**, click **View network connections**.
- c. Right-click **LAN connection** and then select **Properties**.
- d. Select the **Network mode** tab. Under **This connection uses the following items**, click **Internet Protocol Version 4 (TCP/IPv4)** and then click **Properties**.
- e. Select **Use the following IP address**.
- f. In the **IP address** field, type the first 3 octets of the IP address of the reader/controller unit.
- g. For the last octet, type a number that differs from the last octet in the reader/controller's IP address. The actual number used is not important as long as it does not match that of the reader/controller.

Example: if the bar code scanner's IP address is 192.168.3.100, set your PC's IP address to 192.168.3.101.

- h. In the Subnet mask field, type 255.255.255.0
- i. In the **Default gateway** field, type 0.0.0.0
- j. Click **OK**.

- 4. Open a web browser and enter the IP address for the BCL 900i. If the correct IP address is entered, the BCL 900i **Log On** window will appear.



NOTE: the default IP address for all **BCL 900i** units is: 192.168.3.100 (setup) and 172.27.101.220 (host).

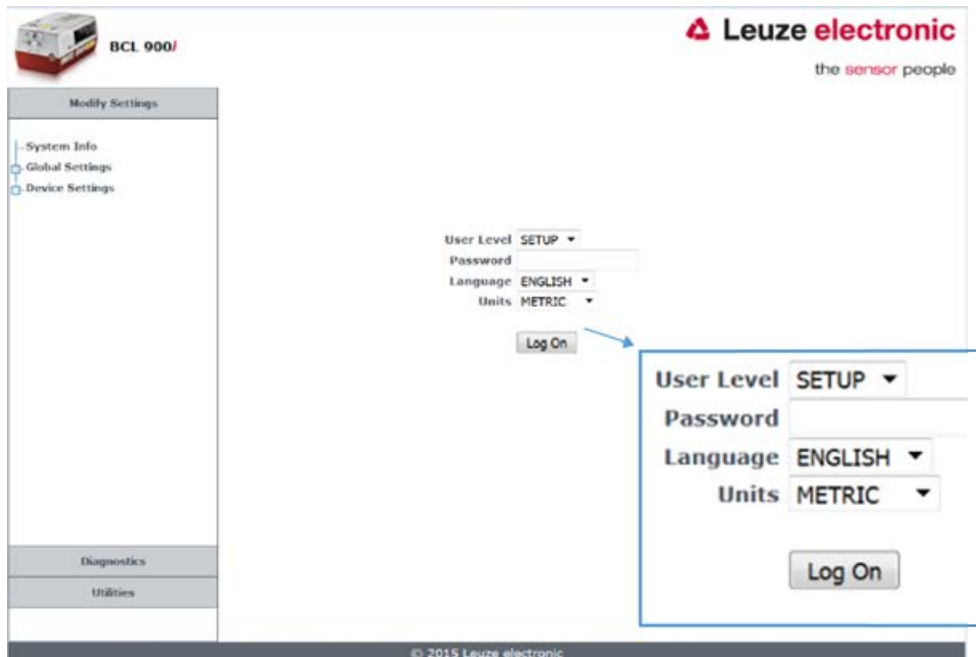

- 5. Enter the **password** (default is LEUZE) for your system in the field provided.
- 6. Select a language from those available in the **Language** drop-down list.
- 7. Select **METRIC** or **IMPERIAL** from the **Units** drop-down list.
- 8. Click **Log On**.

If the password is valid, the application enables all functions available to the user and displays the **System Info** window.

If the password is not valid, the application displays a results box with the message "**Incorrect Password**". Click **OK** to return to the **Log On** window and enter the correct user name and password. If you don't know the password, contact your system manager.

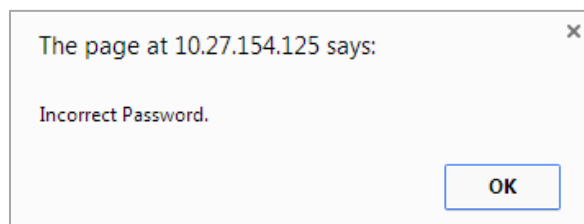

To log out of the user interface:

Click  at the upper right corner of the user interface window to log out. When you log out, the "Log On" window will appear.

4.2 USER INTERFACE BASICS

4.2.1 Menu tree of BCL 900i user interface

The functions that you can select are displayed in a menu tree on the left-hand side of the reader/controller user interface. The function list is organized much like the hierarchy of a file system, where you can expand items that are preceded by a box (☐) to further sub-levels until you find a function of interest.

Sub-levels appear indented below the items from which they are expanded. Clicking the box again will collapse that branch of the menu. If there is no box to the left of an item, then the menu branch cannot be expanded further.

The menu tree of the reader/controller user interface appears with no items expanded. Click the folders to display the active window for the setup function and/or expand the folders to view any additional setup functions.

4.2.2 Entering text using the Text entry tool

In cases where text needs to be entered to create message headers, trailers, custom messages or for other reasons, the **Text entry tool** pencil icon “✎” will be displayed.

Click ✎ to open the **Text entry tool**.

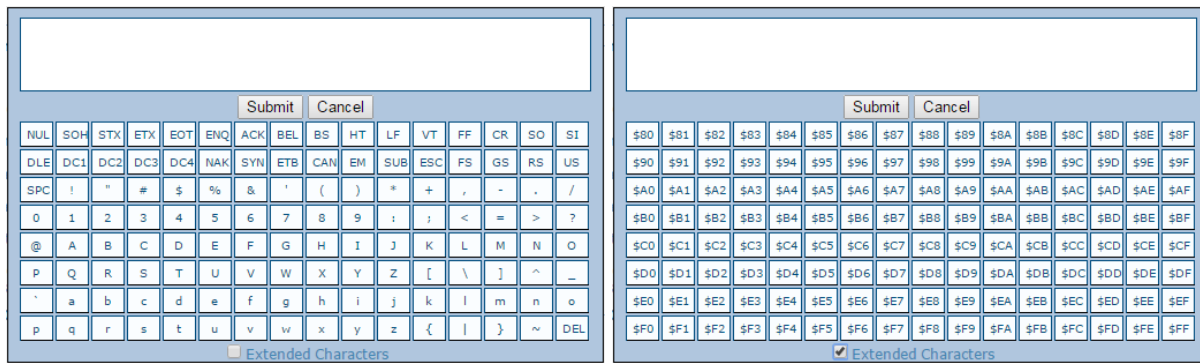

NOTE: the **Text entry tool** is needed to enter characters that cannot be printed or typed. For example, <CR> is a single character presented as a string for easier reading.

The character must be entered with the tool; if typed normally, it will be recognized as a string and not as a single character.

You can enter text in the text field by typing, or click the character buttons to create your message. Select the **Extended characters** check box to reveal a new set of control characters.

Click **Submit** to adopt your text in the original window text field or click **Cancel** to return to the original window without transferring text.

4.2.3 Getting help

The complete help for the **BCL 900i user interface** is available in this manual.

To access the complete help system:

Select **Utilities | Help** in the user interface menu tree.

4.3 MODIFY SETTINGS

During initial setup, use the options in the Modify Settings menu tree to configure your scanning system. If necessary, you can make modifications to the configuration later using the same menu options.



4.4 MODIFY SETTINGS | SYSTEM INFO

Use **System info** to identify and name the scanning system (whether it includes one scanner or an array), to identify master or stand-alone systems, to find the scanners contained in the system and to distribute software from the master scanner to slave scanners in the system.

To view and edit system information:

1. In the menu tree under **Modify settings**, click System info. The System info window opens.

2. Enter the appropriate information in the form described below:

Field name	Action/definition
System Info	
System Description	Enter a name for the scanning system in the text field.
Role	Select Standalone or Master from the drop-down list. Standalone (not controllers) indicates a scan point with a single bar code scanner. Master indicates that the system is made up of more than one bar code scanner in a master and slave configuration.
	 NOTE: the MSC 900 controller will always be shown as Master and cannot be changed.
Release of automatic slave exchange	There are two ways to replace a defective scanner: <ul style="list-style-type: none"> • If the check box is not selected: replacement is done only by pressing the RESTORE button (see section 4.8.1) on the scanner or using the Edit drop-down list. • If the check box is selected: replacement is completely automatic. Automatic replacement also works during operation (hot replacement) without the system having to be switched off and on again.

Master tools

Discover scanners Click **Discover scanners** to automatically find all of the scanners in an array. The scanners found will be listed in the **Device information** part of the window. This step is only done during initial configuration and is not a troubleshooting option.



Distribute software Click **Distribute software** to send the current software installed on the master scanner to all of the slave scanners listed in the **Device information** section of the window.

Device information

Status **Green** = No errors and ready to read
Gray = Unit not connected (unit not found by master)
Red = Error. If you click the red circle, it will take you to the status viewer page for more info on the error

Model Displays an image of the scanner/controller model

Dev Displays the system designation for the device

MAC address Displays the MAC address (media access control address) for the device

Software version Displays the software version installed on the device.

Description Enter a user-defined description of the device.

ID Click **ID** to visually identify a scanner in an array/tunnel. When clicked, all the scanner lasers will switch off except for the selected scanner, whose laser flashes for 20 seconds.

Edit Click this menu to select the **Remove, Reassign, Add** or **Replace** functions from the Edit drop-down list to perform the following actions:

- **Remove:** used to select the scanner to be removed from the Dev/MAC Address drop-down list. Click **OK** to remove the selected scanner from the system.
- **Reassign:** displays a drop-down list of Dev numbers in the Dev column of the selected slave scanner (selected with ID). Select a different number to be reassigned to the scanner.
- **Add:** this is an option under the **Edit** drop-down list in the **Unconfigured devices** section of the screen. Click **OK** to add the selected device to the system.
- **Replace:** this is an option under the **Edit** drop-down list in the **Unconfigured devices section of the screen.** When selected, you can select devices (*those scanners with a gray indicator, meaning the unit is not connected*) from a list of slave scanners in the system using the **MAC** address and **Dev** drop-down lists. Click **OK** to replace the selected scanner with the **Unconfigured device**.

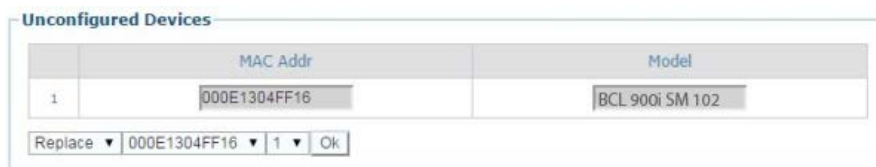

3. When you have finished making changes, click **Update** to save or click **Reset** to revert to the previously saved values.

4.5 MODIFY SETTINGS | GLOBAL SETTINGS

During initial setup, use the Global settings menu tree to configure your **BCL 900i bar code scanning system**. Global settings are applied to the system master and then distributed by the master scanner to the slave devices. If necessary, you can make modifications to the global settings later using the same menu options.



4.5.1 Modify settings | Global settings | Operating mode

Use "Operating mode" to select an operating mode and to configure the parameters associated with this operating mode. The three operating modes available are **Online**, **Continuous** and **PackTrack** and the available settings differ depending on the operating mode selected.

To edit the system operating mode:

1. In the menu tree under **Modify settings**, navigate to **Global settings | Operating mode**. The Operating mode window opens.

Operating Mode

Operating Mode Selection On Line ▼

On Line Options 1 Input Used ▼

Trigger Source

Start Input Number Trigger (Input 1) ▼

Start Input Active Level Active Open ▼

Reading Phase Timeout

Timeout (ms) 500 msec

Timeout Counting From Stop ▼

Verifier Settings

Verifier Enable

Verifier Code ✎

Store Input Aux (Input 3) ▼

Active Level Active Closed ▼

Wrong Code Tx

Wrong String Tx

Wrong String(max. 128 chars) ✎

Beam Shutter Settings

Beam Shutter Disabled ▼

2. Enter the appropriate information in the form described below:

Operating mode Select **Online**, **Continuous** or **PackTrack** from the "Operating mode selection" drop-down list.

Online Select **1 input used**, **2 inputs used** or **Serial** from the **Online options** drop-down list. Each selection has a different set of parameters as described below. In this operating mode, the reading phase is defined as the time between the **Phase ON** and **Phase OFF** events. The phase events can be signals coming from one or two external presence sensors connected to the scanner inputs, or serial start/stop strings sent from the host over the serial interface or the Ethernet input.

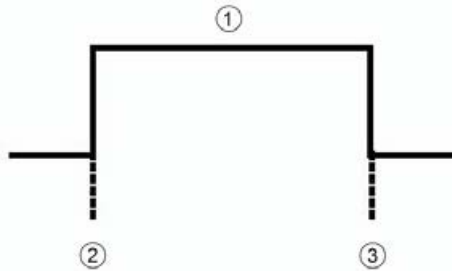

- ① Reading phase
- ② External trigger active
- ③ External trigger inactive

1 input used The reading phase takes place during the active phase of the presence sensor when the scanner tries to acquire and correctly decode the code. If the operation is successful, the bar code characters are transmitted on the serial interface or Ethernet input in the format defined by the current configuration, and the right output event is triggered at the end of the photoelectric sensor's active phase. If a code cannot be decoded, a "No Read" message is sent and the "No Read" event is triggered at the end of the photoelectric sensor's active phase.

Trigger source	
Start input number	Select the input number from the selections available in the drop-down list. This option defines the numbered input that will start the trigger cycle.
Start input active level	Select Active open or Active closed from the drop-down list. <ul style="list-style-type: none"> • Active open: the input is active when there is no current flowing through the IN pins. The input from the trigger source functions as a normally closed contact. The scanner changes to trigger mode when the input source is opened. • Active closed: the input is active when current flows through the IN pins. The input from the trigger source functions as a normally open contact. The scanner changes to trigger mode when the input source is closed.
Reading phase timeout	Select the check box to define a timeout for the Online serial operating mode and the Online 1 input operating mode.

Timeout (ms) Enter a timeout in milliseconds (from 40 to 15000 ms) in the field provided. The **Timeout** represents the period of time for the reading phase.

Timeout counting from Select **Start** or **Stop** from the drop-down list.

- When **Start** is selected, the **Timeout** used to determine the reading phase will begin from the **Start input** or **Serial start string** (normal operation)
- When **Stop** is selected, the **Timeout** used to determine the reading phase will begin from the **Stop input** or **Serial stop string** (normal operation).

Verifier settings

Verifier enable Select the check box to enable the **Code verifier** operating mode.

Verifier code Click  to activate the Text Entry Tool and create the string text used as the match code for the decoded codes. Use characters from **NUL** (00H) to (7EH). Click **Submit** to adopt your text in the original window text field or click **Cancel** to return to the original window without transferring text.

Store input Select an option from the drop-down list to define the number of the input used to automatically store the verifier code. This input must be activated before the reading phase starts; the verifier code must be read and then after the end of the reading phase the input must be deactivated.

Active level Select **Active open** or **Active closed** from the drop-down list to define the active state of the input.

- **Active open:** the input is active when there is no current flowing through the IN pins. The input from the test mode source functions as a normally closed contact. The scanner changes to trigger mode when the input source is opened.
- **Active closed:** the input is active when current flows through the IN pins. The input from the test mode source functions as a normally open contact. The scanner changes to trigger mode when the input source is closed.

Wrong code Tx Select the check box to enable transmission of the Wrong code (non-valid code) message.

Wrong string Tx Select the check box to enable transmission of the Wrong string (non-valid string) message.

Wrong string (max. 128 chars) Enter a text string to be sent in case of a mismatch (wrong code read/non-valid code).

Beam shutter settings	
Beam shutter	<p>Select Disabled, Triggered or Enabled from the drop-down list. The beam shutter switches off the laser. The optional beam shutter can be used to increase the overall laser diode life when used in high ambient temperatures (over 35° C), to reduce power consumption and to switch off the laser for safety reasons.</p> <ul style="list-style-type: none"> • Disabled: the laser is always on. • Triggered: the laser is switched off as soon as the code(s) are read or when the reading phase ends. The laser is switched on again when the next reading phase starts. • Enabled: the laser is always off and all operations are suspended.
2 inputs used	<p>The reading phase is defined by 2 inputs. It starts when the Start input is activated and stops when the Stop input is deactivated (unless the Extended phase is enabled).</p>
Trigger source	
Extended phase	<p>Available only for the Online/2 inputs option. If selected, the Stop input can end the reading phase only if the Start input is also deactivated.</p>
Start input number	<p>Select an input from the drop-down list to define the number of the input starting the reading phase.</p>
Start input active level	<p>Select Active open or Active closed from the drop-down list.</p> <ul style="list-style-type: none"> • Active open: the input is active when there is no current flowing through the IN pins. The input from the trigger source functions as a normally closed contact. The scanner changes to trigger mode when the input source is opened. • Active closed: the input is active when current flows through the IN pins. The input from the trigger source functions as a normally open contact. The scanner changes to trigger mode when the input source is closed.
Stop input number	<p>Select an input from the drop-down list to define the input ending the reading phase.</p>
Active level of the stop input	<p>Select Active open or Active closed from the drop-down list to define the active state of the input.</p> <ul style="list-style-type: none"> • Active open: the input is active when there is no current flowing through the IN pins. The input from the trigger source functions as a normally closed contact. The scanner changes to trigger mode when the input source is opened. • Active closed: the input is active when current flows through the IN pins. The input from the trigger source functions as a normally open contact. The scanner changes to trigger mode when the input source is closed.

Reading phase timeout	If selected, a timeout can be defined for the Serial On Line mode and the On Line 1 Input mode.
------------------------------	---

Stop phase edge	Select Trailing or Leading from the drop-down list to define the signal edge of the stop input used by the scanner as reference for ending the reading phase:
------------------------	---

- **Trailing:** the reading phase ends when the package has completely passed by the stop input.
- **Leading:** the reading phase ends as soon as the stop input detects the front edge of the package.

Beam shutter settings

Beam shutter	Select Disabled , Triggered or Enabled from the drop-down list. The beam shutter switches off the laser. The optional beam shutter can be used to increase the overall laser diode life when used in high ambient temperatures (over 35°C), to reduce power consumption and to switch off the laser for safety reasons.
---------------------	--

- **Disabled:** the laser is always on.
- **Triggered:** the laser is switched off as soon as the code(s) are read or when the reading phase ends. The laser is switched on again when the next reading phase starts.
- **Enabled:** the laser is always off and all operations are suspended.

Serial	In Serial/online operating mode, the reading phase starts when the Serial start string is received on the serial interface and ends when the Serial stop string is received or when a programmed Reading phase timeout expires.
---------------	---

If decoding is correct, the data is transmitted on the serial interface as defined by the configuration. The output line selected for the right output event is activated and the respective message is transmitted on the serial interface or Ethernet input.

In case of a misread, a No Read message is transmitted on the serial interface. The output line selected for the No Read event is activated and the respective message is transmitted on the serial interface or Ethernet input.

Trigger source

Serial start string (max. 32 characters)	Click  to activate the Text entry tool and create the string text used to signal the beginning of the reading phase. Use characters from NUL (00H) to (7EH). Click Submit to adopt your text in the original window text field or click Cancel to return to the original window without transferring text.
---	--

The **Serial start string** must be different to the **Serial stop string** and **Motor ON/OFF** strings. When **ACK/NAK protocol** or **Energy saving** is enabled, the **Serial start/stop strings** cannot contain ACK/NAK characters.

Serial stop string (max. 32 chars) Click  to activate the **Text entry tool** and create the string text used to signal the end of the reading phase. Use characters from NUL (00H) to (7EH). Click **Submit** to adopt your text in the original window text field or click **Cancel** to return to the original window without transferring text.

The **Serial stop string** must be different to the **Serial start string** and **Motor ON/OFF** strings. When **ACK/NAK protocol** or **Energy saving** is enabled, the **Serial start/stop strings** cannot contain ACK/NAK characters.

Reading phase timeout Select the check box to define a timeout for the **Serial online** operating mode.

Timeout (ms) Enter a timeout in milliseconds (from 40 to 15000 ms) in the field provided. The **Timeout** represents the period of time for the reading phase.

Timeout counting from Select **Start** or **Stop** from the drop-down list.

- When **Start** is selected, the **Timeout** used to determine the reading phase will begin from the **Start input** or **Serial start string** (normal operation)
- When **Stop** is selected, the **Timeout** used to determine the reading phase will begin from the **Stop input** or **Serial stop string** (normal operation).

Beam shutter settings

Beam shutter Select **Disabled**, **Triggered** or **Enabled** from the drop-down list. The beam shutter switches off the laser. The optional beam shutter can be used to increase the overall laser diode life when used in high ambient temperatures (over 35°C), to reduce power consumption and to switch off the laser for safety reasons.

- **Disabled:** the laser is always on.
- **Triggered:** the laser is switched off as soon as the code(s) are read or when the reading phase ends. The laser is switched on again when the next reading phase starts.
- **Enabled:** the laser is always off and all operations are suspended.

Continuous The reading phase is always active and allows two or more codes to be read if placed along the same scan line. Code transmission is identical to the other operating modes except that there is no transmission on the serial interface in case of a no read.

Mode setting

Code filter Select **Disable**, **Timeout**, **Encoder steps** or **Tx line** from the **Online options** drop-down list. This parameter determines criteria for deleting entries from the code filter list depending on the type of list management:

- The **Code filter depth** parameter, when not = 0, manages a FIFO (First In First Out) list of codes which are compared for filtering. The **Timeout** and **Encoder steps** values are in addition to the cyclical deletion of entries when the FIFO list depth is exceeded.

- When **Code filter** is set to **Tx line**, an internal list is managed where each entry is deleted when the **Tx line** distance is exceeded.

The application program inherently compares codes based on content and code length.

Each code filter criterion has its own relative value parameter.

- **Disable:** no additional criteria are applied. If code filtering is enabled through the Code Filter Depth parameter, the FIFO list is only modified by new code entries (FIFO list depth exceeded).
- **Timeout:** a timeout measured in milliseconds is also applied to each code entry. The current code entry is deleted from the list when the timeout expires.
- **Encoder steps:** a threshold value measured in encoder steps is also applied to each code entry. The current code entry is deleted from the list when the number of encoder steps is exceeded.
- **Tx line:** the distance measured in mm to the transmit line is applied to each code entry. The current code entry is deleted from the list when the distance in mm is exceeded. If Tx Line is selected, all the networked scanners must have been calibrated using PackTrack (see section 5.6 PackTrack).



NOTE: if Code Filter = Tx Line:

The "Code Filter Depth" parameter is no longer available because the application program manages an internal list which depends solely on the number of codes decoded before the Tx Line is reached.

Any code which, through comparison of the filter conditions, is determined to be identical to a code in the list will be discarded, and to increase precision the x, y, z position coordinates of the code in the list is set as the average between the two readings.

$$x=x1+x2/2, y=y1+y2/2, z=z1+z2/2$$

Use encoder Select the check box to activate the encoder settings.

Code filter depth In **Continuous** operating mode, **Code filter depth** is used to avoid multiple reads of the same code. The entered value (other than zero) defines the number of codes to be saved in a FIFO (First In First Out) list.

When a code is read, it is compared to the list. The application program inherently compares codes based on content and code length. If the list contains a code identical to the current code being read, the current code is discarded. If not, the current code is accepted and added to the list in the first position; the remaining codes in the list are shifted. If the list is full, the oldest code in the list is deleted.

If the value is 0, there is no FIFO list and there is no filtering.

Selection: a value from 0 to 127

Example:

Code Filter Depth = 3

List	Code read	Accepted
xxx (no codes in list)	A	Yes
Axx	B	Yes
BAX	B	No
BAX	C	Yes
CBA	D	Yes
DCB	A	Yes
ADC	A	No

Filter number of encoder steps Enter a number of encoder steps from 1 to 15000. This parameter sets the number of encoder steps after which the **FIFO (First In First Out)** list entry is deleted.

Filter timeout value (ms) Enter a timeout value in milliseconds in the field provided. A value between 40 and 15000 ms may be used. This value sets the time limit after which the **FIFO (First In First Out)** list entry is deleted.

Replicate same code when symbologies don't match Select the check box to define a further code filter condition according to which a read code is added to the list or discarded. This parameter is available if the **Code filter depth** value is other than zero or if the Code Filter value is Tx Line.

In addition to the inherent content and code length comparison, this parameter compares the code type (symbology). If the current code being read is identical to a code contained in the list in terms of content, length and type, the current code is discarded. If not, the current code is accepted and added to the list in the first position; the remaining codes in the list are shifted. If the list is full, the oldest code in the list is deleted.

Replicate same code when X positions don't match Select the check box to define a further code filter condition according to which a read code is added to the list or discarded. This parameter is available if the **Code filter depth** value is other than zero or if the Code Filter value is Tx Line.

In addition to the inherent content and code length comparison, this parameter compares the X coordinate of the code position. If the current code being read is identical to a code contained in the list in terms of content, length and X coordinate of the code position, the current code is discarded. If not, the current code is accepted and added to the list in the first position; the remaining codes in the list are shifted. If the list is full, the oldest code in the list is deleted.

Replicate same code when Y positions don't match

Select the check box to define a further code filter condition according to which a read code is added to the list or discarded. This parameter is available if the **Code filter depth** value is other than zero or if the Code Filter value is Tx Line.

In addition to the inherent content and code length comparison, this parameter compares the Y coordinate of the code position. If the current code being read is identical to a code contained in the list in terms of content, length and Y coordinate of the code position, the current code is discarded. If not, the current code is accepted and added to the list in the first position; the remaining codes in the list are shifted. If the list is full, the oldest code in the list is deleted.

Replicate same code when Z positions don't match

Select the check box to define a further code filter condition according to which a read code is added to the list or discarded. This parameter is available if the **Code filter depth** value is other than zero or if the Code Filter value is Tx Line.

In addition to the inherent content and code length comparison, this parameter compares the Z coordinate of the code position. If the current code being read is identical to a code contained in the list in terms of content, length and Z coordinate of the code position, the current code is discarded. If not, the current code is accepted and added to the list in the first position; the remaining codes in the list are shifted. If the list is full, the oldest code in the list is deleted.

Continuous threshold (number of scans)

Enter a number *N* of scans without a permissible code in order to ensure code identification in the reading zone. Enter a value from 10 to 32665.

Encoder settings

Physical encoder

Select **Disable** or **Enable** from the drop-down list:

- **Disable:** no encoder is enabled
- **Enable:** a physical encoder is connected to the encoder input and is enabled

Encoder step (hundredths of millimeter)

Enter the step value of the encoder.

Conveyor speed [mm/sec]

This parameter is available only when the physical encoder is disabled. It defines the constant speed of the conveyor in mm/s.

PackTrack	Refer to <i>section 5.6</i> for physical PackTrack installation procedures.
Trigger source	
Start input number	Select an input from the drop-down list to define the number of the input starting the reading phase.
Start input active level	<p>Select Active open or Active closed from the drop-down list to define the active state of the input.</p> <ul style="list-style-type: none"> • Active open: the input is active when there is no current flowing through the IN pins. The input from the trigger source functions as a normally closed contact. The scanner changes to trigger mode when the input source is opened. • Active closed: the input is active when current flows through the IN pins. The input from the trigger source functions as a normally open contact. The scanner changes to trigger mode when the input source is closed.
Transmission edge	<p>Select Trailing or Leading from the drop-down list to define the signal edge of the stop input used by the scanner as reference for ending the reading phase:</p> <ul style="list-style-type: none"> • Trailing: the reading phase ends when the package has completely passed by the stop input. • Leading: the reading phase ends as soon as the stop input detects the front edge of the package.

Mode setting

Distance from the PS line to the Tx line Enter the distance along the Y axis from the PS (photoelectric sensor) to the TX line (transmit).

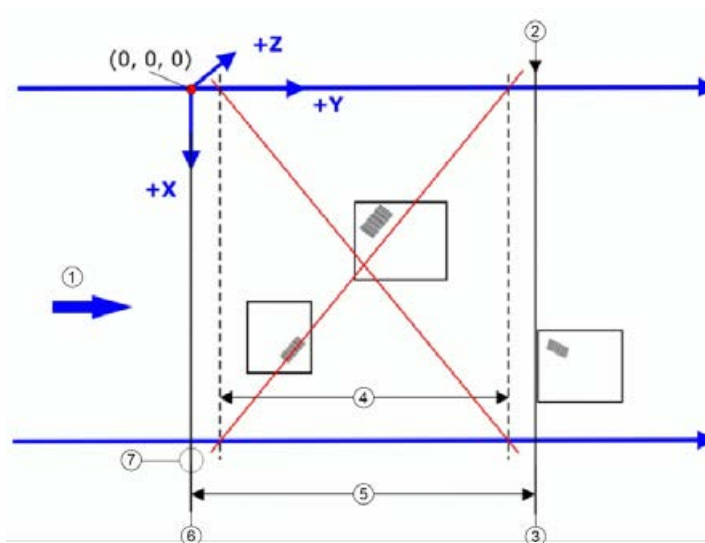

- ① Conveyor direction
- ② End of tracking area
- ③ Tx line
- ④ Reading field
- ⑤ Tracking area
- ⑥ PS line
- ⑦ Photocell or equivalent signal



NOTE: tracking starts 10 cm [4 inches] before and stops 10 cm [4 inches] after the reading field in order to ensure that the bar code is assigned to the correct package.

PS line This parameter defines the read signal Y coordinate (mm) relative to the origin of coordinates used for PackTrack configuration (see below).

Example:

Normally the PS line coincides with the PackTrack reference point, where X, Y, Z = 0.

If the presence sensor (photocell or host PS signal) is moved, you must adjust the PS line accordingly and recalculate the Tx line.

1. PS line = 0; distance from PS line to Tx line = 2500
2. PS line = 500; distance from PS line to Tx line = 2000

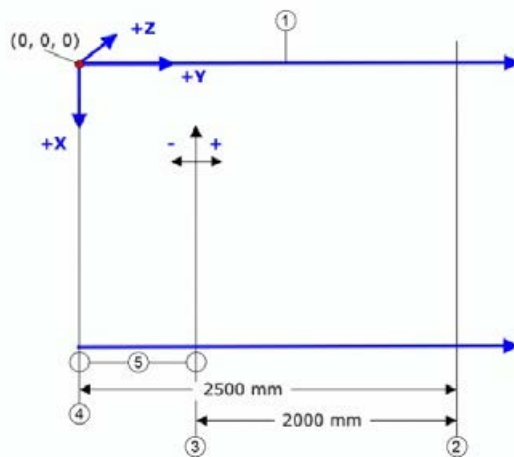

- ① Conveyor direction
- ② Tx line
- ③ New PS line = 500 mm
- ④ Original PS line = 0
- ⑤ Photocell

Minimum pack length	Enter the minimum length of a package in the field provided (mm [in]).
Minimum distance error behavior	Select Ignore Error , Compose or Discard last from the drop-down list. <ul style="list-style-type: none"> • Ignore error: the error is ignored • Compose: enter the Minimum distance between packs in the field provided. • Discard Last: discards all received packages
Minimum distance between packs	Enter the minimum distance (mm, in) between consecutive packages. This field is only available when Compose or Discard last is selected for the Minimum distance error behavior .

Window dimension

Enter a **Window dimension** in the field provided.

The measurement of a bar code position in absolute coordinates performed by the scanners may be affected by an error. For this reason, assignment of the bar code can fail during PackTrack evaluation. With the **Window dimension** parameter, the Y coordinates that delimit the package can be virtually extended to improve the assigning success rate (see the following figure).

If the minimum distance between two consecutive packages is less than twice the **Window dimension** value, the window is dynamically resized (dynamic window) to half the distance between the two packages. The code will be assigned within the **Window dimension** value of the closest package.

If the minimum distance between two consecutive packages is more than twice the **Window dimension** value, the code will be assigned within the **Window dimension** value.

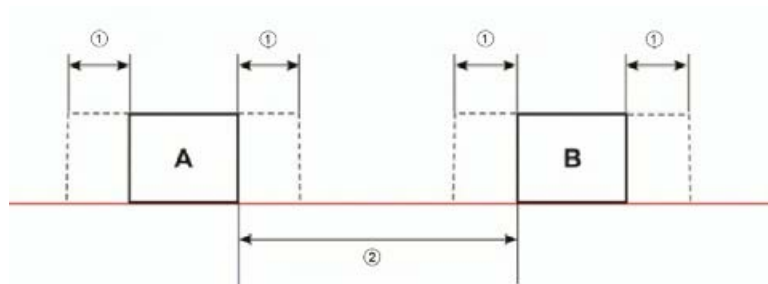

- ① Window dimension
- ② Minimum distance between packages

Encoder settings	
Physical encoder	Select Disable or Enable from the drop-down list: <ul style="list-style-type: none"> Disable: no encoder is enabled Enable: a physical encoder is connected to the encoder input and is enabled
Encoder step (hundredths of millimeter)	Enter the step value of the encoder.
Conveyor speed [mm/sec]	This parameter is available only when Physical encoder is set to Disabled state. It defines the constant speed of the conveyor in mm/s.

Beam shutter settings	
-----------------------	--

Beam shutter	Select Disabled , Triggered or Enabled from the drop-down list. The beam shutter switches off the laser. The optional beam shutter can be used to increase the overall laser diode life when used in high ambient temperatures (over 35°C), to reduce power consumption and to switch off the laser for safety reasons.
---------------------	--

- **Disabled:** the laser is always on.
- **Triggered:** the laser is switched off as soon as the code(s) are read or when the reading phase ends. The laser is switched on again when the next reading phase starts.
- **Enabled:** the laser is always off and all operations are suspended.

PackTrack beam shutter timeout	Select a time value from the drop-down list. This parameter is available only when Operating mode = PackTrack and Beam shutter = Triggered . By setting this parameter, the laser is switched off as soon as the selected timeout expires.
---------------------------------------	--

3. When you have finished making changes, click **Update** to save or click **Reset** to revert to the previously saved values.

4.5.2 Modify settings | Global settings | Barcode settings table

Use **Barcode settings table** to select and configure bar codes to be read in your application.

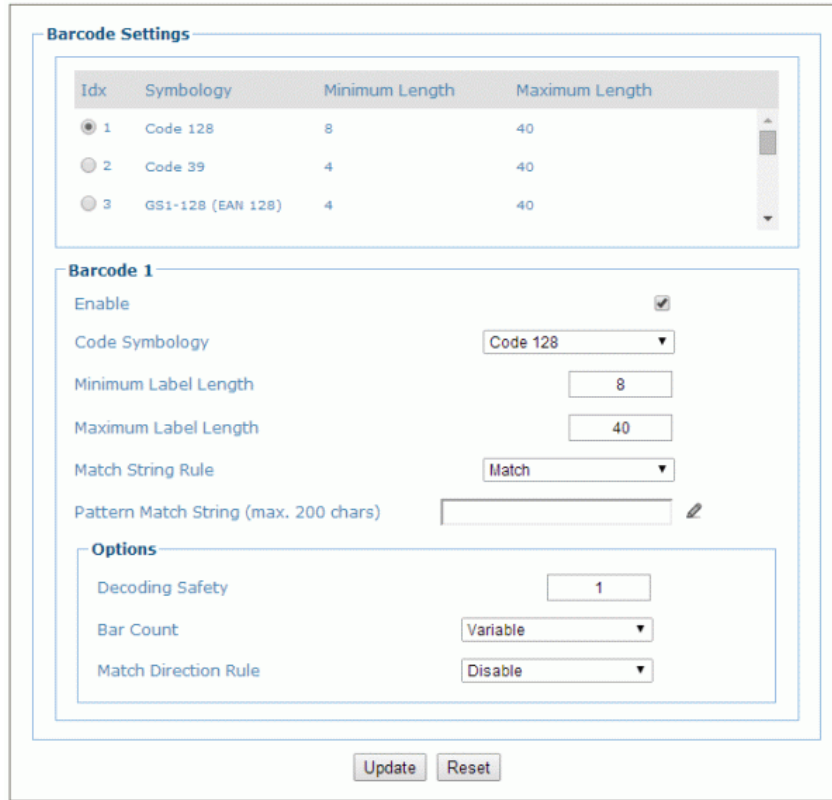

To edit the bar code settings:

1. In the menu tree under **Modify settings**, navigate to **Global settings | Barcode settings table**. The **Barcode settings** window opens.



2. Enter the appropriate information in the form described below:

Field name	Action/definition
Top panel	Displays a list of bar codes that have been added to the system, with the following columns:
Idx	Select an option button for the row/bar code you want to edit. <ul style="list-style-type: none"> • If a bar code type is displayed in the selected row, its configuration can then be edited. • If a row displaying disabled is selected, a bar code type can be selected and configured for that row.
Symbology	Displays the name of the bar code symbology for that row. If no symbology has been added for a row, Disabled is displayed.
Minimum length	Displays the minimum bar code character length for that row's symbology.
Maximum length	Displays the maximum bar code character length for that row's symbology.

Barcode n	 NOTE: input fields will vary depending on the selected symbology.
Release	Select the Enable check box to activate the selected bar code. Deselect the Enable check box to disable the selected bar code. If the check box has been selected, configuration and code type options are displayed.
Code symbology	Select a bar code symbology from those available in the Code symbology drop-down list.
EAN Add On	Select No Add On , 2 digit Add On or 5 digit Add On from the EAN Add On drop-down list. Selecting 2 digit Add On or 5 digit Add On adds that many digits as a supplement to the bar code. EAN is the acronym for International Article Number, previously known as European Article Number .
Minimum label length	Enter the minimum character length for the selected bar code.
Maximum label length	Enter the maximum character length for the selected bar code.
Match string rule	Select Match or Do not match from the drop-down list. This parameter defines the matching rule, according to which a code can be transmitted. <ul style="list-style-type: none"> • Match: all codes matching the pattern match string will be transmitted • Do not match: all codes not matching the pattern match string will be transmitted
Pattern match string (max. 200 chars)	Click  to activate the Text Entry Tool and enter a pattern match string. A code can also be identified by its content. A pattern match string is programmable for each code and if the read codes do not match the defined string, a No Read event will be returned.

It is possible to define the match string by inserting:

- all printable characters
- non-printable ASCII characters available in the list which appears by right-clicking the parameter edit box
- * defines any string consisting of an undefined number of characters (it may be empty)
- ? identifies any character to be found at the position indicated within the string

If your application requires insertion of ?, * and NUL as characters, you must use the following syntax:

- ? character = <NUL>?
- * character = <NUL>*
- NUL character = <NUL>00
- other extended ASCII characters = <NUL>xy, where xy identifies the hex value of the character

Examples:

Match a code starting with the string 123 and followed by any string of characters:

- Match string = 123*
- Example code = 123aC53

Match a code ending with the string 123 and preceded by any string of characters:

- Match string = *123
- Example code = 41pO123

Match a code with the string 123 at any position:

- Match string = *123*
- Example code = 41pO123253

Match a code starting with the string 123 followed by three generic characters and an undefined string of characters, in this case no character:

- Match string = 123???*
- Example code = 123ad2

Match any code consisting of four characters:

- Match string = ????
- Example code = gT6k

Match a code with 6 characters at any position, with 12 as the central characters:

- Match string = *??12??*
- Example code = data12og35

The following is an example of a very complex string where ? and * are used both as commands and as characters:

- Match string = *45<NUL>??*??AC<NUL>*251?*
- Example code = GEN45?3iusdsAC*2516300



NOTE: for **Codabar** codes, the start/stop characters must be considered in the match conditions.
For all codes which use check digits, if the **check digit** is transmitted, it must be considered in the match conditions.

Options



NOTE: input fields will vary depending on the selected symbology.

Decoding Reliability

Enter a number from **1** to **100** (**1** = control disabled) in the field provided. A check verifies that *N* number of decodes are performed with the same result before code reading is accepted as valid.

Check digit

Select the check box to improve decoding reliability: it is generally the last digit to the right of the code and verifies the validity of the preceding digits. The calculation technique and number of check digits depend on the code selected.

It is advised to enable the check digit whenever correct code identification is difficult. The following bar code symbologies include check digits in their definitions:

- Code 128
- EAN/UPC
- Code 93

For these symbologies, the check digit control is not allowed.

Check digit type Select a customized check digit for **Standard, German, DHL, Daimler-Chrysler** or **Bosch** from the drop-down list.

Check digit Tx Select the check box to include the check digit in the code transmitted.

Bar count Select **Variable** or an available value from the drop-down list. The bar count allows further specification of the number of elements in the read code for Code 128, GS1-128, Code 93, ISBT 128 or Code 39 Full ASCII.

For these codes, the same number of bar code elements (bars + spaces) can be associated with a different number of characters.

- **Variable:** to select the correct number of characters, set Label Length to the desired fixed value and Bar Count to Variable



12
Code 128
Subset A



12
Code 128
Subset C

Digit number 2, bar count variable

- **Code 128 or GS1-128:** from 25 to 499 - a variable number of characters in steps of 6.
- **Code 93 or ISBT 128:** from 25 to 385 - a variable number of characters in steps of 6.
- **Code 39 full ASCII:** from 29 to 619 - a variable number of characters in steps of 10.

To select a particular bar code length in elements, set Bar count to the desired fixed value and Label length to Variable.



12
Code 128
Subset A



1234
Code 128
Subset C

Digit number variable, bar count 31

Match direction rule Select **Disable, Forward** or **Reverse** from the drop-down list. This parameter defines the direction according to which a code can be transmitted. The direction refers to the code direction with respect to the scan line, in particular: **Forward** = the code start character precedes the stop character in the scan line (Start Ch + Code + Stop Ch); **Reverse** = the code stop character precedes the start character in the scan line (Stop Ch + Code + Start Ch)

- **Disable:** all codes are transmitted irrespective of the direction
- **Forward:** all codes with forward direction are transmitted
- **Reverse:** all codes with reverse direction are transmitted

Start character Tx Select **Disabled, Lower case** or **Upper case** from the drop-down list. This parameter is available only for **Codabar** code symbologies. It enables transmission of the code start character:

- **Disabled:** the character is not selected;
- **Lower case:** the character is transmitted in lower case;
- **Upper case:** the character is transmitted in upper case.

Stop character Tx	Select Disabled , Lower case or Upper case from the drop-down list. This parameter is available only for Codabar code symbologies. It enables transmission of the code stop character: <ul style="list-style-type: none">• Disabled: the character is not selected;• Lower case: the character is transmitted in lower case;• Upper case: the character is transmitted in upper case.
--------------------------	---

3. When you have finished making changes, click **Update** to save or click **Reset** to revert to the previously saved values.

4.5.3 Modify settings | Global settings | Barcode configuration

Use **Barcode configuration** to configure how the system defines a No read bar code, and configure and filter NOREAD messages.

To edit the bar code configuration:

1. In the menu tree under **Modify settings**, navigate to **Global settings | Barcode configuration**. The **Barcode configuration** window opens.

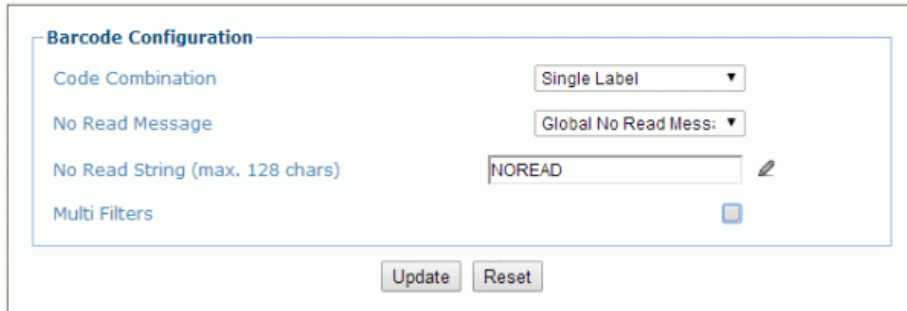

2. Enter the appropriate information in the form described below:

Field name	Action/definition
Code combination	<p>Select Single label, Standard multi label, Logical combination or Code collection from the drop-down list. The "Code combination" parameter selects the decoding mode for the scanner.</p> <ul style="list-style-type: none"> • Single label: in this operating mode, only one bar code can be read in each reading phase; however, it can be determined automatically from up to 10 enabled codes. The scanner stops decoding as soon as a code is read. If the code is not read during the reading phase, the No Read message is produced. • Standard multi label: in Multi label operating mode, the bar codes selected (up to 10) will all be read in the same reading phase. If the reading phase terminates before all the codes are read, a Global no read message will be produced, unless it is disabled, in which case a Local no read will be produced. <p> NOTE: in case of Multi label, the codes will be distinguished EITHER by their symbology OR by their contents. If two (or more) codes share the same symbology and content, the scanner will perceive them as a single code.</p> <ul style="list-style-type: none"> • Logical combination: in Logical combination operating mode, the codes of the groups defined by the logical combination rule are read in the same reading phase. • Code collection: in Code collection operating mode, expected codes are collected within a single reading phase in the order in which they are read. The No Read message is produced only if none of the codes are read. Up to 50 codes can be collected.

Barcode configuration > Single label

If **Single label** has been selected from the **Code combination** drop-down list, the Barcode configuration window displays related input fields.

The screenshot shows the 'Barcode Configuration' window. At the top, 'Code Combination' is set to 'Single Label'. Below it, 'No Read Message' is set to 'Global No Read Mess:'. The 'No Read String' field contains 'NOREAD'. The 'Multi Filters' checkbox is checked. The 'Multi-Filter Settings' section includes: 'Contained Filter' (checked), 'Max Number of Different Characters' (0), 'Voting Filter' (checked), 'Max Number of Different Characters' (2), 'Filter Out Low Height Codes' (checked), 'Minimum Readings Difference Between Scanners' (2), 'Filter Out Single Readings' (unchecked), and 'Strip Filter' (checked). The 'Strip Filter Settings' section includes: 'Strip All Non Printable Chars' (unchecked), 'Char(s) to be Stripped' (empty), 'Strip Filter Collapse' (unchecked), and 'Replacement Char' (#). 'Update' and 'Reset' buttons are at the bottom.

Enter the appropriate information in the form described below:

Field name	Action/definition
Code combination	Single label has been selected.
No read message	Select Disable no read message , Global no read message or Local no read(s) message from the drop-down list. The No Read condition occurs whenever a code cannot be read or decoded. <ul style="list-style-type: none"> • Disable no read message: the No Read message is not transmitted. • Global no read message: the No Read string will be sent if the scanner is unable to decode one or more bar codes in the reading phase. • Local no read(s) message: do not use this option when working in Single label operating mode.
No read string (max. 128 chars)	Click  to activate the Text entry tool and create a string to be displayed when Global no read message is selected from the No read message drop-down list.
Multi filters	Select the check box to display the Multi-filter settings options.

Multi-filter settings

Contained filter

Select the check box to display the **Max Number of Different Characters** field.

When selected, this filter attempts to eliminate false multiple reads by determining whether a read short code is "contained in" (is a sub-string of) another longer read code. This condition implies that the short code is probably a misread of the same longer code and therefore should be ignored (i.e. should not be considered as a multiple read of a different code).

This filter function is based on the following rules:

- a multiple read condition occurs
- all decoded codes of the same type are compared with each other

Rule 1: the shorter code is considered contained in the longer code if the character string is found in the same order; the longer code may have a single block of characters at any position (before, after or in between the compared strings)

Example: the code **123456** is considered as contained in the following codes: 00123456, 12345600, 12378456.

The code **123456** is considered as not contained in the following codes: 1234**6507** (string with different sequence), 12345**700** (string not complete), 120**378456** or **0012345600** (multiple blocks in string).

Rule 2: the shorter code is not filtered by rule 1. In the longer code, all possible sub-strings of the same length as the shorter code string are compared with the shorter code string. The shorter code is considered contained in the longer code if the number of different characters between the compared codes is less than or equal to the "Max Number of Different Characters". The shorter code is filtered by rule 2.

Example:

If Max Number of Different Characters = 1:



The code **123456** is considered contained in the following codes: **12305600**, 00**123056** and 88**123056**88 because there is only one different character in the compared string.

The code **123456** is not considered contained in **123066789** because there are two different characters in the compared string.



CAUTION: if the **Contained filter** parameter is used when **Message Tx selection** (see section 4.5.6) is set to **On decoding**, the filter conditions may be satisfied before the reading phase ends resulting in possible successive multiple read errors.

Max number of different characters	<p>Enter a value from 0 to 5 in the field provided to define the maximum number of different characters allowed to still consider a code as being contained in another one and therefore to be filtered.</p> <p>If the number of different characters between the compared codes exceeds the value of this parameter, the codes are considered as different and will not be filtered (a multiple read of a different code occurs).</p> <p>If the number of different characters between the compared codes is less than or equal to the value of this parameter, the short code is considered as a sub-string of the longer code and will be filtered (no multiple read occurs).</p> <p>Examples:</p> <p>If Max Number of Different Characters = 2: The code 123456 read once is considered the same as the following codes read multiple times: 133056, 123546 and 123457 because there are two or fewer different characters at each position in the compared codes.</p> <p>The code 123456 read once is not considered the same as the following codes read multiple times: 153246, 103057 and 654321 because there are at least three different characters at each position in the compared codes.</p>
Voting filter	<p>Select the check box to display the Max Number of Different Characters field.</p> <p>When selected, this filter attempts to eliminate false multiple reads by comparing the number of different characters at each position between two codes of the same type and length. This condition implies that the reading of a code of the same type and length with very few different characters is probably a misread of the code itself and therefore the code read last should be ignored (i.e. should not be considered as a multiple read of a different code).</p> <p>This filter function is based on the following rules:</p> <ul style="list-style-type: none"> • a multiple read condition occurs; • the two codes are of the same type; • the two codes have the same length; • the number of different characters at each position is equal to or less than the number defined by the Max Number of Different Characters parameter; • Message tx selection (see section 4.5.6) must be set to After reading phase Off.
Filter out low height codes	<p>Select the check box to display the Minimum readings difference between scanners field.</p> <p>Background: this option was developed for airport systems where there are often tall bar height codes and low bar height codes with the same content attached to baggage. Travelers will often remove the large, tall bar height code, while leaving the smaller, low bar height codes attached to the bag. The next time they travel, they may have multiple low bar height codes on their baggage plus the new tall bar height and low bar height codes for the new journey.</p> <p>This option instructs the system to ignore low bar height codes, which are likely read only once or twice, in favor of tall bar height codes, which will likely be read multiple times.</p> <p>This function is used in tunnel applications where multiple bar codes are read and there is a need to filter out one of the bar codes. If less than x number of scanners read the bar code, then it will be considered a NOREAD for that code.</p>
Minimum readings difference between scanners	<p>Enter the minimum number of scanners that must read a bar code for it to be considered a valid read.</p>
Filter out single readings	<p>With the check box selected, if only 1 scanner reads a code, it will be considered a NOREAD.</p>
Strip filter	<p>Select the check box to display the Strip filter settings options. This is a second level filter that when enabled allows the elimination of characters not managed by the host.</p>

Strip filter settings	
Strip all non printable chars	Select the check box to remove all non- printable ASCII characters from the code (000-020 and 127).
Char(s) to be stripped	Click  to activate the Text entry tool and enter specific characters to be stripped from the code. Click Submit to adopt your text in the original window text field or click Cancel to return to the original window without transferring text.
Strip filter collapse	Select the check box to remove the stripped characters from the code and, therefore, reduce the code length (collapsed). The code length can even be zero.
Replacement char	Click  to activate the Text entry tool and enter the substitution character to replace all the stripped ones. Click Submit to adopt your text in the original window text field or click Cancel to return to the original window without transferring text.

- When you have finished making changes, click **Update** to save or click **Reset** to revert to the previously saved values.

Barcode configuration > Standard multi label

If **Standard multi label** has been selected from the **Code combination** drop-down list, the Barcode configuration window displays related input fields.



NOTE: in case of Multi label, the codes will be distinguished EITHER by their symbology OR by their contents. If two (or more) codes share the same symbology and content, the scanner will perceive them as a single code.

1. Enter the appropriate information in the form described below:

Field name	Action/definition
Code combination	Standard Multi Label has been selected.
No read message	<p>Select Disable no read message, Global no read message or Local no read(s) message from the drop-down list. The No Read condition occurs whenever a code cannot be read or decoded.</p> <ul style="list-style-type: none"> • Disable no read message: the No Read message is not transmitted. • Global no read message: the No Read string will be sent if the scanner is unable to decode one or more bar codes in the reading phase. • Local no read(s) message: this option is useful when one or more codes are not read in the reading phase or when more codes than the expected number set by the configuration parameters are read. <p>In Standard multi label operating mode, this option activates the Code label local no read string and the Code label local multiple read string parameters which allow a Local no read string and a Local multiple read string to be set for each defined code symbology.</p>
No read string (max. 128 chars)	Click to activate the Text entry tool and create a string to be displayed when Global no read message is selected from the No read message drop-down list. Click Submit to adopt your text in the original window text field or click Cancel to return to the original window without transferring text.

Multiple read message	Select Disable or Enable from the drop-down list. This string will be sent if, during the reading phase, the scanner reads more than the number of the expected bar codes set by the configuration parameters.
Multiple read string (max. 128 chars)	Click  to activate the Text entry tool and create a string to be displayed in case of Multiple read message . Click Submit to adopt your text in the original window text field or click Cancel to return to the original window without transferring text. This parameter is only available when Multiple read message is enabled and the No read message selection is different from the string for local No Read(s). It is possible to select either the ASCII or HEX value. If the parameter is disabled, the scanner transmits the first code read.
Send all multiple read labels	For Advanced data format only, enabling this parameter causes all multiple read labels to be included in the output message. They can be separated by the Multiple read separator . Multiple read label separator string (max. 128 chars): <ul style="list-style-type: none"> • The multiple read label separators (up to 128 bytes) are used to separate multiple read bar codes in the reading phase. • This is meaningful when the "Code combination" parameter is set to "Multi label" or "Logical combination" and the "Send all multiple read labels" parameter has been enabled. • If selected, they appear within the code field and are transmitted after each decoded multiple read bar code.
Multi filters	Select the check box to display the Multi-filter settings options.

Multi-filter settings

Contained filter	<p>Select the check box to display the Max Number of Different Characters field.</p> <p>When selected, this filter attempts to eliminate false multiple reads by determining whether a read short code is "contained in" (is a sub-string of) another longer read code. This condition implies that the short code is probably a misread of the same longer code and therefore should be ignored (i.e. should not be considered as a multiple read of a different code).</p> <p>This filter function is based on the following rules:</p> <ul style="list-style-type: none"> • a multiple read condition occurs • all decoded codes of the same type are compared with each other <p>Rule 1: the shorter code is considered contained in the longer code if the character string is found in the same order; the longer code may have a single block of characters at any position (before, after or in between the compared strings)</p> <p>Example: the code 123456 is considered as contained in the following codes: 00<u>123456</u>, <u>123456</u>00, <u>12378456</u>.</p> <p>The code 123456 is considered as not contained in the following codes: 12346507 (string with different sequence), 12345700 (string not complete), 120378456 or 0012345600 (multiple blocks in string).</p> <p>Rule 2: the shorter code is not filtered by rule 1. In the longer code, all possible sub-strings of the same length as the shorter code string are compared with the shorter code string. The shorter code is considered contained in the longer code if the number of different characters between the compared codes is less than or equal to the "Max Number of Different Characters". The shorter code is filtered by rule 2.</p>
-------------------------	--

Example:

If Max Number of Different Characters = 1:

The code **123456** is considered contained in the following codes: **12305600**, **00123056** and **8812305688** because there is only one different character in the compared string.

The code **123456** is not considered contained in **123066789** because there are two different characters in the compared string.



CAUTION: if the Contained filter parameter is used when **Message Tx selection** (see *section 4.5.6*) is set to **On decoding**, the filter conditions may be satisfied before the reading phase ends resulting in possible successive multiple read errors.

Max number of different characters

Enter a value from 0 to 5 in the field provided to define the maximum number of different characters allowed to still consider a code as being contained in another one and therefore to be filtered.

If the number of different characters between the compared codes exceeds the value of this parameter, the codes are considered as different and will not be filtered (a multiple read of a different code occurs).

If the number of different characters between the compared codes is less than or equal to the value of this parameter, the short code is considered as a sub-string of the longer code and will be filtered (no multiple read occurs).

Examples:

If **Max number of different characters** = 2:

The code **123456** read once is considered the same as the following codes read multiple times: **133056**, **123546** and **123457** because there are two or fewer different characters at each position in the compared codes.

The code **123456** read once is not considered the same as the following codes read multiple times: **153246**, **103057** and **654321** because there are at least three different characters at each position in the compared codes.



Voting filter

Select the check box to display the **Max Number of Different Characters** field.

When selected, this filter attempts to eliminate false multiple reads by comparing the number of different characters at each position between two codes of the same type and length. This condition implies that the reading of a code of the same type and length with very few different characters is probably a misread of the code itself and therefore the code read last should be ignored (i.e. should not be considered as a multiple read of a different code).

This filter function is based on the following rules:

- a multiple read condition occurs;
 - the two codes are of the same type;
 - the two codes have the same length;
 - the number of different characters at each position is equal to or less than the number defined by the **Max Number of Different Characters** parameter;
 - **Message tx selection** (see *section 4.5.6*) must be set to **After reading phase Off**.
-

Filter out low height codes	Select the check box to display the Minimum readings difference between scanners field . Background: this option was developed for airport systems where there are often tall bar height codes and low bar height codes with the same content attached to baggage. Travelers will often remove the large, tall bar height code, while leaving the smaller, low bar height codes attached to the bag. The next time they travel, they may have multiple low bar height codes on their baggage plus the new tall bar height and low bar height codes for the new journey. This option instructs the system to ignore low bar height codes, which are likely read only once or twice, in favor of tall bar height codes, which will likely be read multiple times. This function is used in tunnel applications where multiple bar codes are read and there is a need to filter out one of the bar codes. If less than <i>x</i> number of scanners read the bar code, then it will be considered a NOREAD for that code.
Minimum readings difference between scanners	Enter the minimum number of scanners that must read a bar code for it to be considered a valid read.
Filter out single readings	With the check box selected, if only 1 scanner reads a code, it will be considered a NOREAD.
Strip filter	Select the check box to display the Strip filter settings options. This is a second level filter that when enabled allows the elimination of characters not managed by the host.
Strip filter settings	
Strip all non printable chars	Select the check box to remove all non- printable ASCII characters from the code (000-020 and 127).
Char(s) to be stripped	Click  to activate the Text Entry Tool and enter specific characters to be stripped from the code. Click Submit to adopt your text in the original window text field or click Cancel to return to the original window without transferring text.
Strip filter collapse	Select the check box to remove the stripped characters from the code and, therefore, reduce the code length (collapsed). The code length can even be zero.
Replacement char	Click  to activate the Text Entry Tool and enter the substitution character to replace all the stripped ones. Click Submit to adopt your text in the original window text field or click Cancel to return to the original window without transferring text.

- When you have finished making changes, click **Update** to save or click **Reset** to revert to the previously saved values.

Barcode configuration > Logical combination

If **Logical combination** has been selected from the **Code combination** drop-down list, the Barcode configuration window displays related input fields.

Barcode Configuration

Code Combination: Logical Combination

Logical Combination Rule: 1

No Read Message: Global No Read Mess

No Read String (max. 128 chars): ?

Multiple Read Message: Disable

Send All Multiple Read Labels: Disable

WebSentinel - Partial Read Is Treated As: Good Read

Multi Filters:

Multi-Filter Settings

Contained Filter:

Maximum Number of Different Characters: 0

Voting Filter:

Maximum Number of Different Characters: 2

Filter Out Low Height Codes:

Minimum Readings Difference Between Scanners: 2

Filter Out Single Readings:

Strip Filter:

Strip Filter Settings

Strip All Non Printable Chars:

Char(s) to be Stripped:

Strip Filter Collapse:

Replacement Char: #

Update Reset

1. Enter the appropriate information in the form described below:

Field name	Action/definition
Code combination	Standard multi label has been selected.

Logical combination rule Click  to activate the code group selection dialog box.

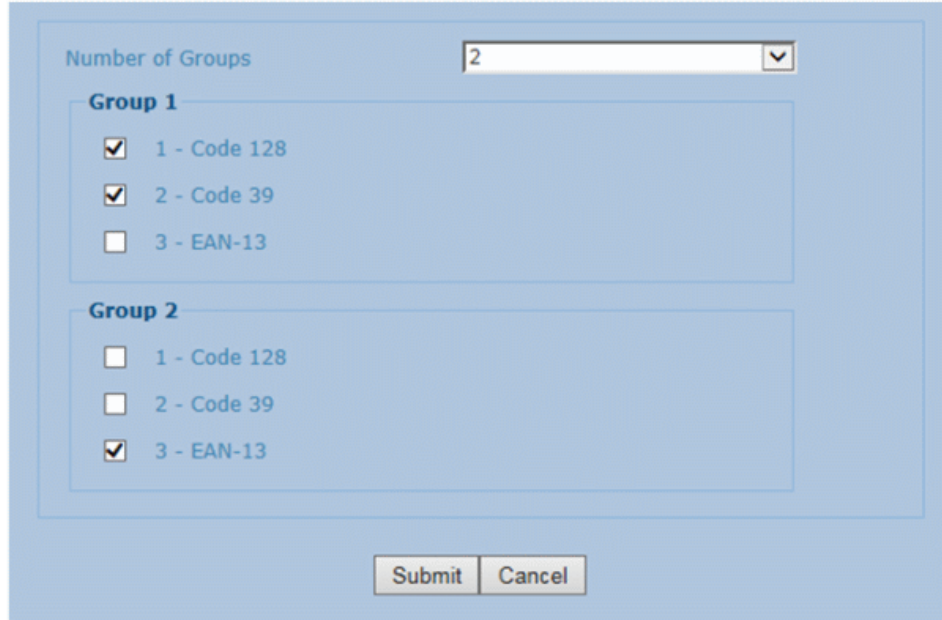

In the "Number of Groups" drop-down list, select the number of groups you want to use. Then select the check box next to the group/code you want to define. Click **Submit** to adopt your text in the original window text field or click **Cancel** to return to the original window without transferring text.

Groups and their order define the output message format, while each group identifies an expected code.

When editing the logical combination rule, proceed as follows:

1. Define the bar code settings that define the type of expected code labels. It is possible to define up to 10 different code types;
2. Define how many code types (groups) are expected by editing the combination rule using the following logical operators. Each group may include one or more selected code types.

& = AND operator which separates a group from the previous/following one;

^ = XOR operator to be used to combine different code labels within the same group. It allows reading of one of the defined code labels.

The maximum number of groups to be defined for each rule string is 15.

If "Local No Read Message" is selected from the "No Read Message" drop-down list, the "Group No Read Messages" parameter group is displayed in which a string for local No Read has to be defined for each group.

Examples: logical combination rule

For all the following examples, the **No read message** parameter is set to **Global no read message**.

Example 1

Code label setting #1 = Code 128

Logical combination rule = 1&1

Defines 2 groups, each of which expects a Code 128 label.

Symbology of decoded codes		Output message
First label #1	Second label #1	
---	---	<header><global no read message><terminator>
X	---	<header><global no read message><terminator>
---	X	<header><global no read message><terminator>
X	X	<header><Code 128 data><data packet separator><Code 128 data><terminator>



NOTE: if **Multiple read message** is enabled and a third label belonging to the Code 128 symbology is decoded, the **Multiple read string** is transmitted instead. If the **Multiple read message** is disabled, the third code label is ignored and only the first two codes are transmitted.

For advanced formatting, if the **Send all multiple read labels** parameter is enabled, then all three labels are sent in the output message; the multiple read label is separated by its own **Multiple read label separator string** which should be different from the **Data packet separator** (DPS).

Example 2

Code label setting #1 = Code 39

Code label setting #2 = Code 128

Logical combination rule = 1^2

Defines a single group that expects a Code 128 label OR a Code 39 label.

Symbology of decoded codes		Output message
Label #1	Label #2	
---	---	<header><global no read message><terminator>
X	---	<header><Code 39 data><terminator>
---	X	<header><Code 128 data><terminator>
X	X	<header><first decoded code/multiple read message string ><terminator>

Example 3

Code label setting #1 = EAN 8

Code label setting #2 = UPC-A

Logical combination rule = 1&1&1^2

Defines three different groups. The first two groups expect an EAN 8 label while the third one expects an EAN 8 label OR an UPC-A label.

Symbology of decoded codes				Output message
First label #1	Second label #1	Third label #1	Label #2	
---	---	---	---	<header><global no read message><terminator>
X	---	---	---	<header><global no read message><terminator>
---	X	---	---	<header><global no read message><terminator>
---	---	X	---	<header><global no read message><terminator>
---	---	---	X	<header><global no read message><terminator>
X	X	X	---	<header><EAN 8 data><DPS><EAN 8 data><DPS><EAN 8 data><terminator>
X	X	---	X	<header><EAN 8 data><DPS><EAN 8 data><DPS><UPC-A data><terminator>
X	X	X	X	<header><EAN 8 data><DPS><EAN 8 data><DPS><first decoded code/multiple read message string><terminator>

Example 4

Code label setting #1 = Code 93
 Code label setting #2 = Interleaved 2/5
 Code label setting #3= EAN-8
 Code label setting #4= UPC-A

Logical combination rule = 1^2&3^4

Defines 2 groups, each of which expects one of the defined code types. The first group may expect a Code 93 label or an Interleaved 2/5 label. The second group may expect an EAN-8 label or an UPC-A label.



Symbology of decoded codes				Output message
Label #1	Label #2	Label #3	Label #4	
---	---	---	---	<header><global no read message><terminator>
X	---	---	---	<header><global no read message><terminator>
---	X	---	---	<header><global no read message><terminator>
---	---	X	---	<header><global no read message><terminator>
---	---	---	X	<header><global no read message><terminator>
X	X	---	---	<header><global no read message><terminator>
X	---	X	X	<header><Code 93><DPS><first decoded code/multiple read message string><terminator>
X	X	X	---	<header><first decoded code/multiple read message string><DPS><EAN 8 data><terminator>
---	X	X	X	<header>< Interleaved 2/5 data><DPS><first decoded code/multiple read message string><terminator>
X	---	X	---	<header><Code 93 data><DPS><EAN 8 data><terminator>
X	---	---	X	<header><Code 93 data><DPS><UPC-A data><terminator>
---	X	X	---	<header><Interleaved 2/5 data><DPS><EAN 8 data><terminator>
---	X	---	X	<header><Interleaved 2/5 data><DPS><UPC-A data><terminator>
X	X	X	X	<header><first decoded code/multiple read message string><DPS><first decoded code/multiple read message string ><terminator>

No read message

Select **Disable no read message**, **Global no read message** or **Local no read(s) message** from the drop-down list. The **No read** condition occurs whenever a code cannot be read or decoded.

- **Disable no read message:** the No Read message is not transmitted.
- **Global no read message:** the No Read string will be sent if the scanner is unable to decode one or more bar codes in the reading phase.
- **Local no read(s) message:** this option is useful when one or more codes are not read in the reading phase or when more codes than the expected number set by the configuration parameters are read.

In Standard multi label operating mode, this option activates the Code label local no read string and the Code label local multiple read string parameters which allow a Local no read string and a Local multiple read string to be set for each defined code symbology.

Non-read string (max. 128 characters)	Click  to activate the Text entry tool and create a string to be displayed when Global no read message is selected from the No read message drop-down list. Click Submit to adopt your text in the original window text field or click Cancel to return to the original window without transferring text.
Multiple read message	Select Disable or Enable from the drop-down list. This string will be sent if, during the reading phase, the scanner reads more than the number of the expected bar codes set by the configuration parameters.
Multiple read string (max. 128 characters)	Click  to activate the Text entry tool and create a string to be displayed in case of Multiple read message. Click Submit to adopt your text in the original window text field or click Cancel to return to the original window without transferring text. This parameter is only available when Multiple read message is enabled and the No read message selection is different from the string for local No Read(s). It is possible to select either the ASCII or HEX value. If the parameter is disabled , the scanner transmits the first code read.
Send all multiple read labels	For Advanced data format only, enabling this parameter causes all multiple read labels to be included in the output message. They can be separated by the Multiple read separator . Multiple read label separator string (max. 128 chars): The multiple read label separators (up to 128 bytes) are used to separate multiple read bar codes in the reading phase. This is meaningful when the "Code combination" parameter is set to "Multi label" or "Logical combination" and the "Send all multiple read labels" parameter has been enabled. If selected, they appear within the code field and are transmitted after each decoded multiple read bar code.
WebSentinel – Partial read is treated as	Select No read , Good read or Partial read from the drop-down list. This determines how WebSentinel handles the partial read.
Multi filters	Select the check box to display the Multi-filter settings options.

Multi-filter settings

Contained filter	<p>Select the check box to display the Max Number of Different Characters field.</p> <p>When selected, this filter attempts to eliminate false multiple reads by determining whether a read short code is "contained in" (is a sub-string of) another longer read code. This condition implies that the short code is probably a misread of the same longer code and therefore should be ignored (i.e. should not be considered as a multiple read of a different code).</p> <p>This filter function is based on the following rules:</p> <ul style="list-style-type: none"> • a multiple read condition occurs • all decoded codes of the same type are compared with each other <p>Rule 1: the shorter code is considered contained in the longer code if the character string is found in the same order; the longer code may have a single block of characters at any position (before, after or in between the compared strings)</p> <p>Example: the code 123456 is considered as contained in the following codes: 00123456, 12345600, 12378456.</p> <p>The code 123456 is considered as not contained in the following codes: 12346507 (string with different sequence), 12345700 (string not complete), 120378456 or 0012345600 (multiple blocks in string).</p> <p>Rule 2: the shorter code is not filtered by rule 1. In the longer code, all possible sub-strings of the same length as the shorter code string are compared with the shorter code string. The shorter code is considered contained in the longer code if the number of different</p>
-------------------------	---

characters between the compared codes is less than or equal to the "Max Number of Different Characters". The shorter code is filtered by rule 2.

Example:

If Max Number of Different Characters = 1:

The code **123456** is considered contained in the following codes: **12305600**, **00123056** and **8812305688** because there is only one different character in the compared string.

The code **123456** is not considered contained in **123066789** because there are two different characters in the compared string.



CAUTION: if the Contained filter parameter is used when **Message Tx selection** (see section 4.5.6) is set to **On decoding**, the filter conditions may be satisfied before the reading phase ends resulting in possible successive multiple read errors.

Max number of different characters

Enter a value from 0 to 5 in the field provided to define the maximum number of different characters allowed to still consider a code as being contained in another one and therefore to be filtered.

If the number of different characters between the compared codes exceeds the value of this parameter, the codes are considered as different and will not be filtered (a multiple read of a different code occurs).

If the number of different characters between the compared codes is less than or equal to the value of this parameter, the short code is considered as a sub-string of the longer code and will be filtered (no multiple read occurs).

Examples:

If Max Number of Different Characters = 2:

The code **123456** read once is considered the same as the following codes read multiple times: **133056**, **123546** and **123457** because there are two or fewer different characters at each position in the compared codes.

The code **123456** read once is not considered the same as the following codes read multiple times: **153246**, **103057** and **654321** because there are at least three different characters at each position in the compared codes.



Voting filter

Select the check box to display the **Max Number of Different Characters** field.

When selected, this filter attempts to eliminate false multiple reads by comparing the number of different characters at each position between two codes of the same type and length. This condition implies that the reading of a code of the same type and length with very few different characters is probably a misread of the code itself and therefore the code read last should be ignored (i.e. should not be considered as a multiple read of a different code).

This filter function is based on the following rules:

- a multiple read condition occurs;
 - the two codes are of the same type;
 - the two codes have the same length;
 - the number of different characters at each position is equal to or less than the number defined by the **Max Number of Different Characters** parameter;
 - **Message tx selection** (see section 4.5.6) must be set to **After reading phase Off**.
-

Filter out low height codes	<p>Select the check box to display the Minimum readings difference between scanners field.</p> <p>Background: this option was developed for airport systems where there are often tall bar height codes and low bar height codes with the same content attached to baggage. Travelers will often remove the large, tall bar height code, while leaving the smaller, low bar height codes attached to the bag. The next time they travel, they may have multiple low bar height codes on their baggage plus the new tall bar height and low bar height codes for the new journey.</p> <p>This option instructs the system to ignore low bar height codes, which are likely read only once or twice, in favor of tall bar height codes, which will likely be read multiple times.</p> <p>This function is used in tunnel applications where multiple bar codes are read and there is a need to filter out one of the bar codes. If less than <i>x</i> number of scanners read the bar code, then it will be considered a NOREAD for that code.</p>
Minimum readings difference between scanners	Enter the minimum number of scanners that must read a bar code for it to be considered a valid read.
Filter out single readings	With the check box selected, if only 1 scanner reads a code, it will be considered a NOREAD.
Strip filter	Select the check box to display the Strip filter settings options. This is a second level filter that when enabled allows the elimination of characters not managed by the host.
Strip filter settings	
Strip all non printable chars	Select the check box to remove all non- printable ASCII characters from the code (000-020 and 127).
Char(s) to be stripped	Click  to activate the Text Entry Tool and enter specific characters to be stripped from the code. Click Submit to adopt your text in the original window text field or click Cancel to return to the original window without transferring text.
Strip filter collapse	Select the check box to remove the stripped characters from the code and, therefore, reduce the code length (collapsed). The code length can even be zero.
Replacement char	Click  to activate the Text Entry Tool and enter the substitution character to replace all the stripped ones. Click Submit to adopt your text in the original window text field or click Cancel to return to the original window without transferring text.

- When you have finished making changes, click **Update** to save or click **Reset** to revert to the previously saved values.

Barcode configuration > Code collection

If **Code collection** has been selected from the Code **combination** drop-down list, the Barcode configuration window displays related input fields.

1. Enter the appropriate information in the form described below:

Field name	Action/definition
Code combination	Code collection has been selected.
No read message	<p>Select Disable no read message, Global no read message or Local no read(s) message from the drop-down list. The No Read condition occurs whenever a code cannot be read or decoded.</p> <ul style="list-style-type: none"> • Disable no read message: the No Read message is not transmitted. • Global no read message: the No Read string will be sent if the scanner is unable to decode one or more bar codes in the reading phase. • Local no read(s) message: this option is useful when one or more codes are not read in the reading phase or when more codes than the expected number set by the configuration parameters are read. <p>In Standard multi label operating mode, this option activates the Code label local no read string and the Code label local multiple read string parameters which allow a Local no read string and a Local multiple read string to be set for each defined code symbology.</p>
No read string (max. 128 characters)	Click to activate the Text entry tool and create a string to be displayed when Global no read message is selected from the No read message drop-down list. Click Submit to adopt your text in the original window text field or click Cancel to return to the original window without transferring text.

Multi filters Select the check box to display the **Multi-filter settings** options.

Code collection settings

Associate same codes when read by different scanners Select the check box to enable this function.
This parameter is available only when the **Code combination** parameter is set to *Code collection* and the scanner has the *Master* role. If enabled, it allows the transmission of all codes belonging to the same programmed slot (same symbology and content) but read by different scanners (including the master) in a single instance.

This parameter is available only when the **Code combination** parameter is set to *Code collection* and the scanner has the *Master* role. If enabled, it allows the transmission of all codes belonging to the same programmed slot (same symbology and content) but read by different scanners (including the master) in a single instance.

Scanner role:

- **Master SYNCHRONIZED:** the scanner is connected as the master in a synchronized master/slave configuration.
- **Slave SYNCHRONIZED:** the scanner is connected as a slave in a synchronized master/slave configuration. (See note below.)
- **Other:** this selection is intended for a stand-alone scanner.

Code different when scan gap is greater than

This parameter is available only when the **Code combination** parameter is set to **Code collection**. If the number of scans performed between two consecutive codes read (by the master or stand-alone scanner) is greater than the defined number, the codes will be considered as different.

If the parameter set to 0, the filter function is disabled: if there is no scan gap, all the consecutive codes read will be considered as only one code.

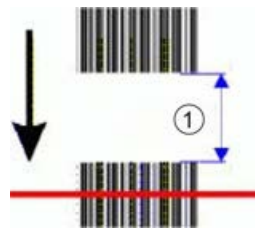

① Scan gap

Code different when code position gap is greater than

This parameter is available only when the **Code combination** parameter is set to *Code collection*. If the position gap between two consecutive codes read (by the master or stand-alone scanner) on the same scan line is greater than the defined gap number, the codes will be considered as different.

If the parameter set to 0, the filter function is disabled: if there is no code position gap, all the consecutive codes read will be considered as only one code.

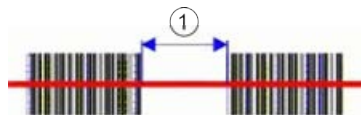



① Code position gap

Multi-filter settings

Contained filter	<p>Select the check box to display the Max Number of Different Characters field.</p> <p>When selected, this filter attempts to eliminate false multiple reads by determining whether a read short code is "contained in" (is a sub-string of) another longer read code. This condition implies that the short code is probably a misread of the same longer code and therefore should be ignored (i.e. should not be considered as a multiple read of a different code).</p> <p>This filter function is based on the following rules:</p> <ul style="list-style-type: none"> • a multiple read condition occurs • all decoded codes of the same type are compared with each other <p>Rule 1: the shorter code is considered contained in the longer code if the character string is found in the same order; the longer code may have a single block of characters at any position (before, after or in between the compared strings)</p> <p>Example: the code 123456 is considered as contained in the following codes: <u>00123456</u>, <u>12345600</u>, <u>12378456</u>.</p> <p>The code 123456 is considered as not contained in the following codes: 12346507 (string with different sequence), 12345700 (string not complete), 120378456 or 0012345600 (multiple blocks in string).</p> <p>Rule 2: the shorter code is not filtered by rule 1. In the longer code, all possible sub-strings of the same length as the shorter code string are compared with the shorter code string. The shorter code is considered contained in the longer code if the number of different characters between the compared codes is less than or equal to the "Max Number of Different Characters". The shorter code is filtered by rule 2.</p> <p>Example:</p> <p>If Max Number of Different Characters = 1:</p> <p>The code 123456 is considered contained in the following codes: 12305600, 00123056 and 8812305688 because there is only one different character in the compared string.</p> <p>The code 123456 is not considered contained in 123066789 because there are two different characters in the compared string.</p>
Max number of different characters	<p>Enter a value from 0 to 5 in the field provided to define the maximum number of different characters allowed to still consider a code as being contained in another one and therefore to be filtered.</p> <p>If the number of different characters between the compared codes exceeds the value of this parameter, the codes are considered as different and will not be filtered (a multiple read of a different code occurs).</p> <p>If the number of different characters between the compared codes is less than or equal to the value of this parameter, the short code is considered as a sub-string of the longer code and will be filtered (no multiple read occurs).</p> <p>Examples:</p> <p>If Max Number of Different Characters = 2:</p> <p>The code 123456 read once is considered the same as the following codes read multiple times: 133056, 123546 and 123457 because there are two or fewer different characters at each position in the compared codes.</p> <p>The code 123456 read once is not considered the same as the following codes read multiple times: 153246, 103057 and 654321 because there are at least three different characters at each position in the compared codes.</p>



CAUTION: if the Contained filter parameter is used when **Message Tx selection** (see section 4.5.6) is set to **On decoding**, the filter conditions may be satisfied before the reading phase ends resulting in possible successive multiple read errors.

Voting filter	<p>Select the check box to display the Max Number of Different Characters field. When selected, this filter attempts to eliminate false multiple reads by comparing the number of different characters at each position between two codes of the same type and length. This condition implies that the reading of a code of the same type and length with very few different characters is probably a misread of the code itself and therefore the code read last should be ignored (i.e. should not be considered as a multiple read of a different code).</p> <p>This filter function is based on the following rules:</p> <ul style="list-style-type: none"> • a multiple read condition occurs; • the two codes are of the same type; • the two codes have the same length; • the number of different characters at each position is equal to or less than the number defined by the Max Number of Different Characters parameter; • Message tx selection (see section 4.5.6) must be set to After reading phase Off.
Filter out low height codes	<p>Select the check box to display the Minimum readings difference between scanners field.</p> <p>Background: this option was developed for airport systems where there are often tall bar height codes and low bar height codes with the same content attached to baggage. Travelers will often remove the large, tall bar height code, while leaving the smaller, low bar height codes attached to the bag. The next time they travel, they may have multiple low bar height codes on their baggage plus the new tall bar height and low bar height codes for the new journey.</p> <p>This option instructs the system to ignore low bar height codes, which are likely read only once or twice, in favor of tall bar height codes, which will likely be read multiple times.</p> <p>This function is used in tunnel applications where multiple bar codes are read and there is a need to filter out one of the bar codes. If less than <i>x</i> number of scanners read the bar code, then it will be considered a NOREAD for that code.</p>
Minimum readings difference between scanners	<p>Enter the minimum number of scanners that must read a bar code for it to be considered a valid read.</p>
Filter out single readings	<p>With the check box selected, if only 1 scanner reads a code, it will be considered a NOREAD.</p>
Strip filter	<p>Select the check box to display the Strip filter settings options. This is a second level filter that when enabled allows the elimination of characters not managed by the host.</p>
Strip filter settings	
Strip all non printable chars	<p>Select the check box to remove all non- printable ASCII characters from the code (000-020 and 127).</p>
Char(s) to be stripped	<p>Click  to activate the Text Entry Tool and enter specific characters to be stripped from the code. Click Submit to adopt your text in the original window text field or click Cancel to return to the original window without transferring text.</p>
Strip filter collapse	<p>Select the check box to remove the stripped characters from the code and, therefore, reduce the code length (collapsed). The code length can even be zero.</p>
Replacement char	<p>Click  to activate the Text Entry Tool and enter the substitution character to replace all the stripped ones. Click Submit to adopt your text in the original window text field or click Cancel to return to the original window without transferring text.</p>

2. When you have finished making changes, click **Update** to save or click **Reset** to revert to the previously saved values.

4.5.4 Modify settings | Global settings | Serial ports

During initial setup, use the options in the "Serial ports" menu tree to configure any serial ports used by your bar code scanning system. If necessary, you can make modifications to the global settings later using the same menu options. This includes:



Modify settings | Global settings | Serial ports | Main port

Use the **Main port** window to configure communication between the scanner and the host or, in a multi-sided layout, between several scanners and a host.

To edit the main port settings:

1. In the menu tree under **Modify settings**, navigate to **Global settings | Serial ports | Main port**. The Main port window opens.

Main Serial Port

Data Tx

Heartbeat Enable Unconditionec

Heartbeat Settings

Heartbeat Timeout sec

Heartbeat Message (max. 32 chars)

Heartbeat Terminator (max. 32 chars)

Line Settings

Main Port Electrical Interface

Handshake



Baud Rate

Parity

Data Bits

Stop Bits

2. Enter the appropriate information in the form described below:

Field name	Action/definition
Data Tx	Select the check box to enable Data Tx . If selected, the Main serial port channel is used by the scanner to transmit data and/or messages.
Heartbeat	Select Disable , Enable unconditioned or Enable conditioned from the drop-down list. This parameter is available if the Data Tx parameter is enabled. It enables/disables the transmission of the heartbeat message signaling that the device is still active. <ul style="list-style-type: none"> • Disable: the heartbeat message is not transmitted • Enable unconditioned: the heartbeat message is always transmitted, even if communication is still active • Enable conditioned: the heartbeat message is transmitted only when there is no communication
Heartbeat settings	
Heartbeat timeout	Enter a time value in seconds to define the amount of time between two message transmissions. If the entered timeout expires and no transmission has occurred, the heartbeat message will be transmitted.
Heartbeat message (max. 32 chars)	Click  to activate the Text entry tool and create the heartbeat header text to signal the beginning of the heartbeat message. Characters from NUL (00H) to (7EH) can be used. Click Submit to adopt your text in the original window text field or click Cancel to return to the original window without transferring text. The (header) string of the Heartbeat message must be different from the Heartbeat terminator string.
Heartbeat terminator (max. 32 chars)	Click  to activate the Text Entry Tool and create the Heartbeat terminator text to signal the end of the heartbeat message. Characters from NUL (00H) to (7EH) can be used. Click Submit to adopt your text in the original window text field or click Cancel to return to the original window without transferring text. The Heartbeat terminator string must be different from the Heartbeat message (header) string.
Line settings	
Main port electrical interface	Select RS232 or RS422 full duplex from the drop-down list. The main serial interface is compatible with these available electrical standards.
Handshake	Select None , Hardware (RTS/CTS) or Software (Xon/Xoff) from the drop-down list. Handshake is a communication control used to protect against data loss; it can be achieved via hardware (RTS\CTS protocol) or software (Xon\Xoff protocol).
Baud rate	Select a value from 1200 to 115200 from the drop-down list. Baud rate is the transmission speed on a data line.
Parity	Select None , Odd or Even from the drop-down list. Parity is a parameter indicating the presence of a control bit in the communication protocol frame.
Data bits	Select 7 or 8 from the drop-down list. Data bits is a parameter indicating the number of bits that form the data packet of the communication protocol frame.
Stop bits	Select 1 or 2 from the drop-down list. Stop bits is a parameter indicating the number of stop bits in the data packet of the communication protocol frame.

3. When you have finished making changes, click **Update** to save or click **Reset** to revert to the previously saved values.

Modify settings | Global settings | Serial ports | Aux port

Use the **Aux port** window to configure communication via the auxiliary serial port. For this communication mode, the RS232 interface is automatically selected.

To edit the aux port settings:

1. In the menu tree under **Modify** settings, navigate to **Global settings | Serial ports | Aux port**. The Aux port window opens.

Aux Serial Port

Search for CBX BM100 at Device Startup

Data Tx

Heartbeat **Enable Unconditionec** ▼

Heartbeat Settings

Heartbeat Timeout sec

Heartbeat Message (max. 32 chars)

Heartbeat Terminator (max. 32 chars)

Line Settings



Baud Rate ▼

Parity ▼

Data Bits ▼

Stop Bits ▼

2. Enter the appropriate information in the form described below:

Field name	Action/definition
Search for MA BM100 at device startup	Select the check box to automatically search for a BM100 storage module when the scanner is switched on.
Data Tx	Select the check box to enable Data Tx . If selected, the Aux serial port channel is used by the scanner to transmit data and/or messages.
Heartbeat	Select Disable , Enable unconditioned or Enable conditioned from the drop-down list. This parameter is available if the Data Tx parameter is enabled. It enables/disables the transmission of the heartbeat message signaling that the device is still active. <ul style="list-style-type: none"> • Disable: the heartbeat message is not transmitted • Enable unconditioned: the heartbeat message is always transmitted, even if communication is still active • Enable conditioned: the heartbeat message is transmitted only when there is no communication
Heartbeat settings	
Heartbeat timeout	Enter a time value in seconds to define the amount of time between two message transmissions. If the entered timeout expires and no transmission has occurred, the heartbeat message will be transmitted.
Heartbeat message (max. 32 chars)	Click  to activate the Text entry tool and create the Heartbeat header text to signal the beginning of the heartbeat message. Characters from NUL (00H) to (7EH) can be used. Click Submit to adopt your text in the original window text field or click Cancel to return to the original window without transferring text. The (header) string of the Heartbeat message must be different from the Heartbeat terminator string.
Heartbeat terminator (max. 32 chars)	Click  to activate the Text entry tool and create the Heartbeat terminator text to signal the end of the heartbeat message. Characters from NUL (00H) to (7EH) can be used. Click Submit to adopt your text in the original window text field or click Cancel to return to the original window without transferring text. The Heartbeat terminator string must be different from the Heartbeat message (header) string.
Line settings	
Baud rate	Select a value from 1200 to 115200 from the drop-down list. Baud rate is the transmission speed on a data line.
Parity	Select None , Odd or Even from the drop-down list. Parity is a parameter indicating the presence of a control bit in the communication protocol frame.
Data bits	Select 7 or 8 from the drop-down list. Data bits is a parameter indicating the number of bits that form the data packet of the communication protocol frame.
Stop bits	Select 1 or 2 from the drop-down list. Stop bits is a parameter indicating the number of stop bits in the data packet of the communication protocol frame.

3. When you have finished making changes, click **Update** to save or click **Reset** to revert to the previously saved values.

4.5.5 Modify settings | Global settings | Ethernet

During initial setup, use the **Ethernet** menu tree options to configure the Ethernet settings for your bar code scanning system.

Ethernet is the most popular physical layer LAN technology in use today. It is the IEEE 802.3 series standard, based on the CSMA/CD access method by which two or more stations are able to share a common cabling system. This access method (carrier sense multiple access with collision detection) is the basis for Ethernet systems that cover a wide speed range.

The design goals for Ethernet are to create a simply defined topology that makes efficient use of shared resources that are easy to reconfigure and maintain and provides compatibility across many manufacturer and systems.

Ethernet supports many different network protocols; Leuze electronic scanners support IP plus TCP or UDP over Ethernet and the 802.3 frame format as a low-level Ethernet protocol.

If necessary, you can make modifications to the global settings later using the same menu options. This includes:

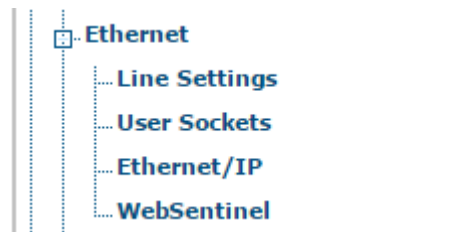

Modify settings | Global settings | Ethernet | Line settings

Use the **Line settings** window to define and report basic information about the system.

To edit the line settings:

1. In the menu tree under Modify settings, navigate to **Global settings | Ethernet | Line settings**. The Line settings window opens.

The screenshot shows a configuration window with two main sections: **Host Network (ETH1)** and **Setup Network (ETH2)**.
Host Network (ETH1) section includes:
 - Enable DHCP: A checkbox that is currently unchecked.
 - IP Address: A text input field containing '10.27.152.192'.
 - IP Netmask: A text input field containing '255.255.248.0'.
 - IP Gateway: A text input field containing '10.27.152.21'.
 - IP DNS1: A text input field containing '0.0.0.0'.
 - IP DNS2: A text input field containing '0.0.0.0'.
Setup Network (ETH2) section includes:
 - Setup IP Address: A text input field containing '192.168.3.101'.
 - Setup Netmask: A text input field containing '255.255.255.0'.
 At the bottom of the window are two buttons: **Update** and **Reset**.

2. Enter the appropriate information in the form described below:

Field name	Action/definition
Host Network (ETH1)	
Enable DHCP	Select the check box to cause the IP address parameters to become inactive. They are then used to display the addresses assigned by a DHCP server during scanner configuration.
IP address	Enter the Internet Protocol network address (IP address) in the field provided. Consult your network administrator to obtain a new address.
Ip netmask	Enter the subnet mask address of the device in the field provided. Consult your network administrator to obtain a new address.
Ip gateway	Enter the gateway address of the device in the field provided. Consult your network administrator to obtain a new address.
IP DNS1	Enter the address of the primary domain name system (DNS) in the field provided.
IP DNS2	Enter the address of the secondary domain name system (DNS) in the field provided.
Setup network (ETH2)	
Setup IP address	Enter the Internet Protocol network address (IP address) for ETH2 (Setup) in the field provided. Consult your network administrator to obtain a new address.
Setup netmask	Enter the subnet mask address for ETH2 (Setup) in the field provided. Consult your network administrator to obtain a new address.

3. When you have finished making changes, click **Update** to save or click **Reset** to revert to the previously saved values.

Modify settings | Global settings | Ethernet | User sockets

Use the **User sockets** (User socket settings) window to setup, edit and configure numbered user sockets for your bar code scanning system. User sockets are another interface available for the Ethernet communication.

To edit the user socket settings:

1. In the menu tree under **Modify settings**, navigate to **Global settings | Ethernet | User sockets**. The User sockets window opens.

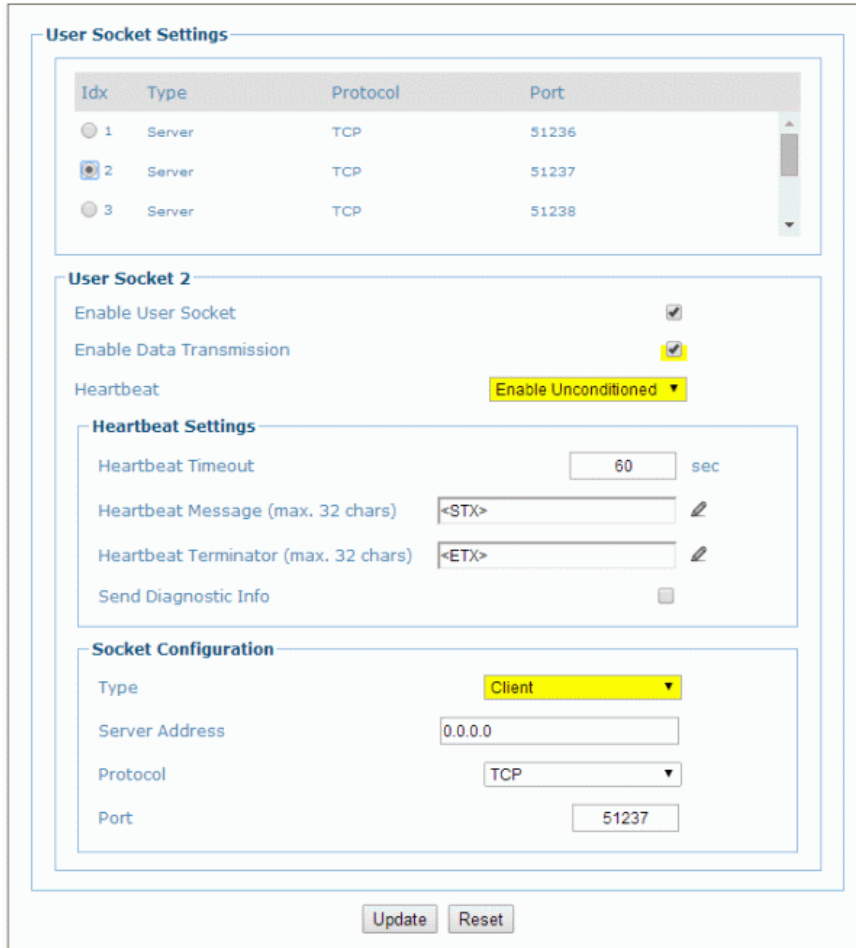



2. Enter the appropriate information in the form described below:

Field name	Action/definition
User socket list	Select an option button in the list at the top of this window to create a new user socket or edit an existing one.
User socket n	
Enable user socket	Select the check box to enable User sockets and display the related configuration options.
Enable data transmission	Select the check box to enable User sockets and display the related configuration options. When enabled, Ethernet user socket is selected as the channel to be used by the scanner for transmitting data and/or messages.

Heartbeat	<p>Select Disable, Enable unconditioned or Enable conditioned from the drop-down list. This parameter is available if the Data Tx parameter is enabled. It enables/disables the transmission of the heartbeat message signaling that the device is still active.</p> <ul style="list-style-type: none"> • Disable: the heartbeat message is not transmitted • Enable unconditioned: the heartbeat message is always transmitted, even if communication is still active • Enable conditioned: the heartbeat message is transmitted only when there is no communication
------------------	---

Heartbeat settings

Heartbeat timeout	<p>Enter a time value in seconds to define the amount of time between two message transmissions. If the entered timeout expires and no transmission has occurred, the heartbeat message will be transmitted.</p>
Heartbeat message (max. 32 chars)	<p>Click  to activate the Text entry tool and create the Heartbeat header text to signal the beginning of the heartbeat message. Characters from NUL (00H) to (7EH) can be used. Click Submit to adopt your text in the original window text field or click Cancel to return to the original window without transferring text.</p> <p>The (header) string of the Heartbeat message must be different from the Heartbeat terminator string.</p>
Heartbeat terminator (max. 32 chars)	<p>Click  to activate the Text entry tool and create the Heartbeat terminator text to signal the end of the heartbeat message. Characters from NUL (00H) to (7EH) can be used. Click Submit to adopt your text in the original window text field or click Cancel to return to the original window without transferring text.</p> <p>The Heartbeat terminator string must be different from the Heartbeat message (header) string.</p>

Socket configuration

Type	<p>Select Server or Client from the drop-down list to define the socket type:</p> <ul style="list-style-type: none"> • Server: the station waits for connections and can communicate with a maximum of 3 clients simultaneously • Client: the station attempts to set up a connection to the server
Server Address	<p>Enter the IP address of the server to which the client is attempting to connect. This parameter is available only if the socket is configured as a Client.</p>
Protocol	<p>Select TCP (Transmission Control Protocol) or UDP (User Datagram Protocol) from the drop-down list to define the protocol to be used for Ethernet communication.</p>



NOTE: when using the **UDP** protocol:

- The user socket client port is bound to the server port.
- The maximum size for maintaining a whole datagram is 1436 bytes; messages exceeding this value will be fragmented.

Port	<p>Enter the port number of the socket.</p>
-------------	---

3. When you have finished making changes, click **Update** to save or click **Reset** to revert to the previously saved values.

Modify settings | Global settings | Ethernet | Ethernet/IP

Use the **Ethernet/IP** window to set up digital inputs and outputs for the bar code scanner.

To enable or disable Ethernet/IP:

1. In the menu tree under **Modify settings**, navigate to **Global settings | Ethernet | Ethernet/IP**. The **Ethernet/IP** window opens.

The screenshot displays the 'Ethernet/IP' configuration window. At the top, there is a section titled 'Ethernet/IP' with a sub-section 'Enable Ethernet/IP' containing a checked checkbox. Below this, there are two main sections: 'Digital Input Lines' and 'Digital Output Lines'. The 'Digital Input Lines' section includes three rows: 'Trigger (Input 1) Echo' with a 'Disable' dropdown, 'Aux (Input 3) Echo' with a 'Disable' dropdown, and 'Phase Echo' with a 'Disable' dropdown. The 'Digital Output Lines' section includes two rows: 'Control Output 1' with a 'Disable' dropdown and 'Control Output 2' with a 'Disable' dropdown. At the bottom of the window, there are two buttons: 'Update' and 'Reset'.

2. Enter the appropriate information in the form described below:

Field name	Action/definition
Enable Ethernet/IP	Select the check box to enable Ethernet/IP and display the related configuration options.
Digital input lines	
Trigger (input 1) echo	Select Disable or Enable from the drop-down list. Select Enable to echo the status of scanner Input 1 to the Ethernet client via bit 0 in byte 0 (LSB) of the input area.
Aux (input 3) echo	Select Disable or Enable from the drop-down list. Select Enable to echo the status of scanner Input 3 to the Ethernet client via bit 1 in byte 0 (LSB) of the input area.
Phase echo	Select Disable or Enable from the drop-down list. Select Enable to echo the scanner Reading phase status to the Ethernet client via bit 7 in byte 0 (LSB) of the input area.
Digital output lines	
Output 1	Select Disable or Enable from the drop-down list. Select Enable to allow the Ethernet client to drive scanner Output 1 via bit 0 in byte 0 (LSB) of the output area.
Output 2	Select Disable or Enable from the drop-down list. Select Enable to allow the Ethernet client to drive scanner Output 2 via bit 1 in byte 0 (LSB) of the output area.

3. When you have finished making changes, click **Update** to save or click **Reset** to revert to the previously saved values.

Modify settings | Global settings | Ethernet | WebSentinel

Use the **WebSentinel™** window to enable and configure the bar code scanner for use with WebSentinel.

To enable or disable WebSentinel:

1. In the menu tree under **Modify settings**, navigate to **Global settings | Ethernet | WebSentinel**. The WebSentinel window opens.

2. Enter the appropriate information in the form described below:

Field name	Action/definition
Release	Select the check box to enable WebSentinel and display the related configuration options.
WebSentinel socket	Select a socket number for WebSentinel from those available in the drop-down list.
Monitor settings	
Conveyor speed check type	Select Percent or Absolute from the drop-down list to determine how the conveyor speed is evaluated.
Max conveyor speed percent error (%)	In the text field provided, enter the percentage of deviation allowed in the conveyor speed before an error is sent. This option is available when Percentage is selected from the Conveyor speed check type drop-down list .
Max conveyor speed absolute error (mm/s)	In the text field provided, enter the milliseconds of deviation allowed in the conveyor speed before an error is sent. This option is available when Absolute is selected from the Conveyor speed check type drop-down list .
Input timeout (secs)	Enter a time interval in seconds after which the input will be checked for errors. If an error is found, it will be sent to WebSentinel.

3. When you have finished making changes, click **Update** to save or click **Reset** to revert to the previously saved values.

4.5.6 Modify settings | Global settings | Messaging

During initial setup, use the messaging options to configure system messaging for your **BCL 900i bar code scanner**. If necessary, you can make modifications to the configuration later using the same menu options. This includes:

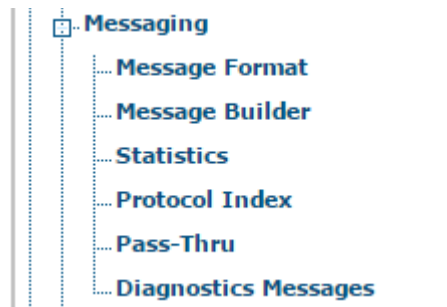

Modify settings | Global settings | Messaging | Message format

Use the **Message format** window to configure Standard or Advanced system messages.

To edit the message format settings:

1. In the menu tree under **Modify settings**, navigate to **Global settings | Messaging | Message format**. The **Message format** window opens.

2. Enter the appropriate information in the form described below:

Messaging formatting

Message format Select Standard or Advanced from the **Format type** drop-down list.

Message Tx selection Select **On decoding** or **After reading phase** from the drop-down list. **Message Tx** selects transmission of the output message on decoding or after the reading phase as illustrated below.

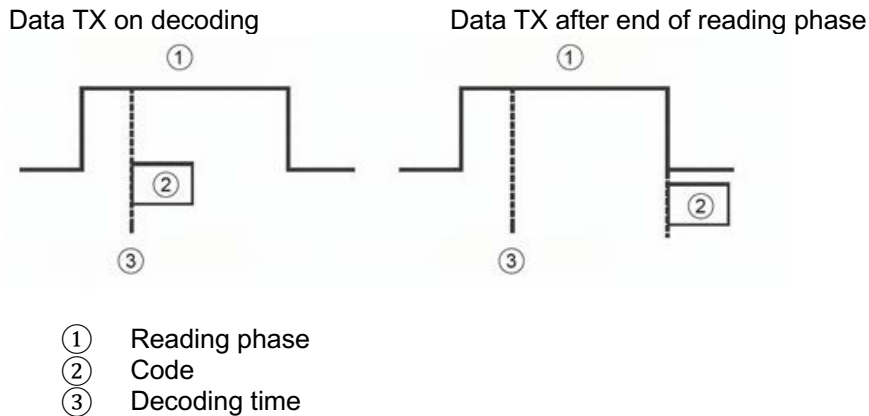

NOTE: this option is only available when an **Operating mode** of **Online** is selected in **Modify settings | Global settings | Operating mode**.

Max. Tx delay after phase off Select **Disabled** or a millisecond value (50 to 500 msec) from the drop-down list. This parameter defines a timeout, which is the maximum delay allowable for message transmission after the reading phase is closed. If this timeout expires before message transmission, the message will be discarded.

NOTE: this option is only available when an **Operating mode** of **Online** is selected in **Modify settings | Global settings | Operating mode**.

Header Tx start Select **With data** or **After reading phase on** from the drop-down list. If **With data** is selected, the header will be transmitted with data. If **After reading phase on** is selected, the header will be transmitted after activation of the reading phase. See the figure below:

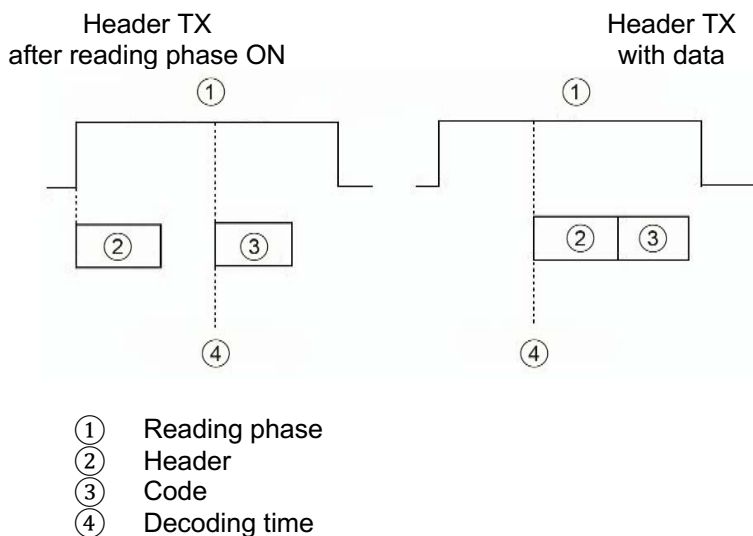

NOTE: this option is only available when an **Operating mode** of **Online** is selected in **Modify settings | Global settings | Operating mode**.

Termination after no read message Select **Enable** or **Disable** from the drop-down list. If **Enable** is selected, a termination string is added to the No Read message string.



NOTE: this option is only available when an **Operating mode** of **Online** is selected in **Modify settings | Global settings | Operating mode**.

Format type: standard

Header string (max. 128 chars) Click to activate the **Text entry tool** and create a **header string** in the text field provided. Headers (up to 128 bytes) can be defined and transmitted as a block preceding the bar code(s). Use characters from NUL (00H) to (7EH).

Click **Submit** to adopt your text in the original window text field or click **Cancel** to return to the original window without transferring text.

Termination string (max. 128 chars) Click to activate the **Text entry tool** and create a **termination string** in the text field provided. Terminators (up to 128 bytes) can be defined and transmitted as a block following the bar code(s). Use characters from NUL (00H) to (7EH). Click **Submit** to adopt your text in the original window text field or click **Cancel** to return to the original window without transferring text.

Data packet separators (max. 128 characters) Click to activate the **Text entry tool** and create a **data packet separator** in the text field provided. The **data packet separators** (up to 128 bytes) are used to separate bar codes in the reading phase. Use characters from NUL (00H) to (7EH).
For this reason, it is very useful when the **Standard multi label**, **Code collection** or **Code combination** parameters have been selected in the **Barcode configuration**. If selected, they appear within the **code field** and are transmitted after each decoded code.
Click **Submit** to adopt your text in the original window text field or click **Cancel** to return to the original window without transferring text.

Code position Tx Select the check box to enable. If enabled, the code position information is included in the output data format.

Code direction designator enable Select the check box to enable. If enabled, you can define the forward and reverse strings indicating the scanning direction relative to the code direction.

Forward direction string (max. 32 chars) Click to activate the **Text entry tool** and create a **forward direction string** in the text field provided. A **forward direction string** can be included in the output message to indicate that the current code has been scanned in the forward direction (scanning from left to right).
This string ("+" is the default value) can be customized by the user and have up to 32 characters.
Click **Submit** to adopt your text in the original window text field or click **Cancel** to return to the original window without transferring text.

Reverse direction string (max. 32 chars) Click to activate the **Text entry tool** and create a **reverse direction string** in the text field provided. A **reverse direction string** can be included in the output message to indicate that the current code has been scanned in the reverse direction (scanning from right to left).
The string ("-") is the default value) can be customized by the user and have up to 32 characters.
Click **Submit** to adopt your text in the original window text field or click **Cancel** to return to the original window without transferring text.

Unknown direction string (max. 32 chars) Click to activate the **Text entry tool** and create an **unknown direction string** in the text field. An **unknown direction string** can be included in the output message when it is not possible to determine the scanning direction of a code.
The string ("?" is the default value) can be customized by the user and have up to 32 characters.
Click **Submit** to adopt your text in the original window text field or click **Cancel** to return to the original window without transferring text.



















Code field length setting Select **Variable** or **Fixed** from the drop-down list. If **Variable** is chosen, all possible code field lengths (number of characters/digits) allowed for the code selected are accepted. If **Fixed** is chosen, only the length defined by the "Code Field Length" parameter is accepted.

Code designator strings

This section of the Message Format window is available only when **User specified** is selected under **Code designator**. Click  to activate the Text entry tool and create a custom code designator string for any listed code symbology. Click **Submit** to adopt your text in the original window text field or click **Cancel** to return to the original window without transferring text.

Code Identifier User Specified ▼

Code Identifier Strings (max 32 chars)

Code 128 Identifier String	C0	
Interleaved 2/5 Identifier String	I0	
Code 39 Identifier String	A0	
Code 93 Identifier String	G0	
Codabar Identifier String	F0	
GS1-128 (ex EAN128) Identifier String	C1	
EAN13 Identifier String	E0	
EAN13 + Add-on 2 Identifier String	E1	
EAN13 + Add-on 5 Identifier String	E2	
EAN-8 Identifier String	E4	
EAN-8 + Add-on 2 Identifier String	E5	
EAN-8 + Add-on 5 Identifier String	E6	
UPC-A Identifier String	E0	
UPC-A + Add-on 2 Identifier String	E1	
UPC-A + Add-on 5 Identifier String	E2	
UPC-E Identifier String	E7	
UPC-E + Add-on 2 Identifier String	E8	
UPC-E + Add-on 5 Identifier String	E9	

Format type: advanced

Select a message number to modify Select a numbered message you want to modify from the drop-down list.

Advanced format: message definition *n*

Message destination Select the check box for each port or socket that should receive the message.

Message destination Bitmap Indicates the destination of the message.

Message alignment Select **None**, **Left** or **Right** from the drop-down list.

Align length Enter the number of characters by which to extend the message when **Left** or **Right** is selected from the **Message alignment** drop-down box.

Align filler char Click  to activate the **Text entry tool** and create a filler character in the text field provided. This filler is used to extend the **Align length**.

Header Click  to activate the **Text entry tool** and create a **header** in the text field provided. Headers (up to 128 bytes) can be defined and transmitted as a block preceding the bar code(s). Use characters from NUL (00H) to (7EH).

Click **Submit** to adopt your text in the original window text field or click **Cancel** to return to the original window without transferring text.

Terminator Click  to activate the **Text Entry Tool** and create a **terminator** in the text field provided. Terminators (up to 128 bytes) can be defined and transmitted as a block following the bar code(s). Use characters from NUL (00H) to (7EH). Click **Submit** to adopt your text in the original window text field or click **Cancel** to return to the original window without transferring text.

Global no read type Select **Only no read**, **Left** or **Right** from the drop-down list.

Global scale type (units) Select **Metric (mm)** or **Imperial (0.1 in)** from the drop-down list.

Code designator Select **Disable**, **Standard AIM ID** or **User specified** from the drop-down list. A **code designator** string can be included in the output message.

- If **Disable** is selected, no code designator is included in the output message.
- If **Standard AIM ID** is selected, the AIM standard designator is included in the output message
- If **User specified** is selected, the **Code designator strings** group is activated at the bottom of the window, allowing you to define a designator string for each code symbology. The string will be included in the output message.

Code designator strings

This section of the "Message format" window is only available when **User specified** is selected under **Code designator**. Click  to activate the **Text entry tool** and create a custom code designator string for any listed code symbology.

Click **Submit** to adopt your text in the original window text field or click **Cancel** to return to the original window without transferring text.

3. When you have finished making changes, click **Update** to save or click **Reset** to revert to the previously saved values.

Modify settings | Global settings | Messaging | Message builder

Use the **Message builder** window to create Standard or Advanced system messages.

To use the Message builder:

1. In the menu tree under **Modify settings**, navigate to **Global settings | Messaging | Message builder**. The **Message builder** window opens.

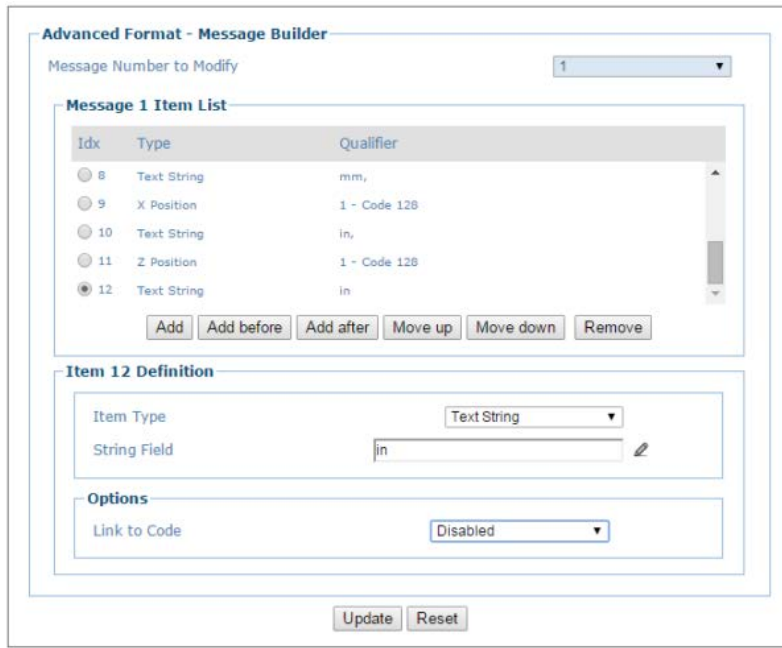

2. Enter the appropriate information in the form described below:

Field name	Action/definition
Message number to modify	Select the number of the message you want to modify from the drop-down list.
Message <i>n</i> item list	
Idx	Displays the index number of the messages.
Type	Displays the message type including various Text string , Code related item or Package related item messages.
Qualifier	Displays relevant qualifiers for the message item if needed.
Add	Click to add a message item to the bottom of the list.
Add before	Click to add a message item above the currently selected message.
Add after	Click to add a message item below the currently selected message.
Move up	Click to move the selected message item up one level in the list.
Move down	Click to move the selected message item down one level in the list.

Remove Click to remove the selected message item.

Item *n* definition

Item type Select **Text string**, **Code related item** or **Package related item** from the drop-down list. Each selection displays a unique set of options.

String field Click  to activate the **Text entry tool** and create a text string message. This option is available when **Item type > Text string** has been selected.

Click **Submit** to adopt your text in the original window text field or click **Cancel** to return to the original window without transferring text.

Code related items Select a code-related item from those available in the drop-down list. This option is available when Item type > Code related item has been selected. The **Code related items** can be associated to a specific programmed code or group label depending on the Code combination selection.

The following options are available:

- **Barcode:** bar code data
- **Barcode length:** number of characters in the code
- **Read bitmap:** 32-bit mask indicating which scanner in the network has read the code (when character <1> is present in the related position)
- **Total read count:** indicates how many times the code has been read by all scanners present in the network during the same reading phase
- **Read count (by device):** indicates the number of times the code has been read by one specific scanner present in the network during the reading phase (selectable from the available devices)
- **X position:** X coordinate for the code that was read
- **Y position:** Y coordinate for the code that was read
- **Z position:** Z coordinate for the code that was read
- **Code designator:** indicates the type of code that was read
- **Code direction:** indicates whether the code has been read from the start character or stop character
- **Code distance:** indicates the distance to the code that was read
- **Decode mode:** indicates if the code has been read using Linear or Reconstruction (CRT) reading mode
- **Decode scans number:** indicates the minimum number of decoded scans referred to the single characters in a code when the device is reading in Reconstruction mode. This item can be used as a code quality index
- **Average code position:** average position of the code in the scan line (average of minimum and maximum code position)
- **Minimum code position:** minimum position of the code in the scan line (closest to the left side/connector side of the scanner)

- **Maximum code position:** maximum position of the code in the scan line (farthest from the left side/connector side of the scanner)
- **Ink spread:** indicates the calculated ink spread value
- **Encoder value:** indicates the encoder/tachometer pulse value from trigger to the code being read
- **Laser number:** if more than one laser is present in the working device, this item indicates the laser used to read the code
- **Reading persistence:** indicates how many times the laser beam has crossed the complete code during the reading phase

Package-related item

Select a package related item from those available in the drop-down list. This option is available when Item type > Package related item has been selected.

The following options are available:

- **Package sequence number:** indicates the sequential number assigned to the package.
- **Total read bitmap:** indicates the complete reading mask referenced to all codes read during the reading phase.
- **Failure bitmap:** 32-bit mask indicating which devices in the network are in the error state (when character <1> is present at the related position).
- **Total read count:** indicates the sum of all code-related total reading counts of each code read during the reading phase.
- **Read count (by device):** indicates the number of codes read during the reading phase by the device.
- **Minimum code distance:** indicates the distance of the code closest to the device read during the reading phase.
- **Maximum code distance:** indicates the distance of the code furthest away from the scanner read during the reading phase.
- **Decode mode (Master):** indicates the programmed reading mode, either Linear or Reconstruction.
- **Number of rejected codes:** indicates the number of codes rejected during the internal analysis (unexpected code, multiple read, discarded by the programmed logical rule).
- **Package length:** indicates the approximate length of the package.
- **Start trigger encoder value:** indicates the encoder/rotation encoder pulse value when the package first hits the trigger PS.
- **End trigger encoder value:** indicates the encoder/rotation encoder pulse value when the package exits the trigger PS.
- **Transmit encoder value:** indicates the encoder/rotation encoder pulse value when the data transmission occurs.
- **Current trigger count:** indicates the number of trigger cycles that have occurred.
- **Working hours (by device):** indicates the total number of hours the device has been active.
- **Total good reads:** indicates the total number of bar codes successfully read.

- **Total no reads:** indicates the total number of bar codes that were not read.
- **Total multi reads:** indicates the number of times packages carried more codes than the scanner is programmed to read.
- **Total partial reads:** indicates the total number of bar codes only partially read.
- **Protocol index:** indicates the programmed protocol index string data.

Code/group selection Select a code/group from those available in the drop-down list. This option is available when **Item type > Code related item** has been selected.

Device index Select a device index number from the drop-down list. This option is available when **Item type > Code related item > Read count (by device) or Type > Package related items > Read count (by device)/Working hours (by device)** has been selected.

Text string: Options

Link to code Select **Disabled**, **Previous code** or **Next code** from the drop-down list.

- **Disabled:** a code will not be linked to this text string.
- **Previous code:** the text string will be linked to the previous generated code.
- **Next code:** the text string will be linked to the next generated code.

Code related item or Package related item: Options

Item alignment Select **None**, **Left** or **Right** from the drop-down list.

Item alignment length Enter an **item alignment length** in the field provided.

Item alignment filler Click  to activate the **Text entry tool** and create filler text. Click **Submit** to adopt your text in the original window text field or click **Cancel** to return to the original window without transferring text.

Item data size Select **Variable** or the number of digits to be used from the drop-down list.

Item data format Select **Decimal (ASCII)**, **Hexadecimal (ASCII)**, **Bitmap (ASCII)** or **Numeric (binary)** from the drop-down list.

3. When you have finished making changes, click **Update** to save or click **Reset** to revert to the previously saved values.

Modify settings | Global settings | Messaging | Statistics

Use the **Statistics** window to select the desired statistical counters, and compose the statistics field and the associated statistics field separator string to be sent to the system by the stand-alone or master scanner.

To edit the statistics settings:

1. In the menu tree under **Modify settings**, navigate to **Global settings | Messaging | Statistics**. The Statistics window opens.

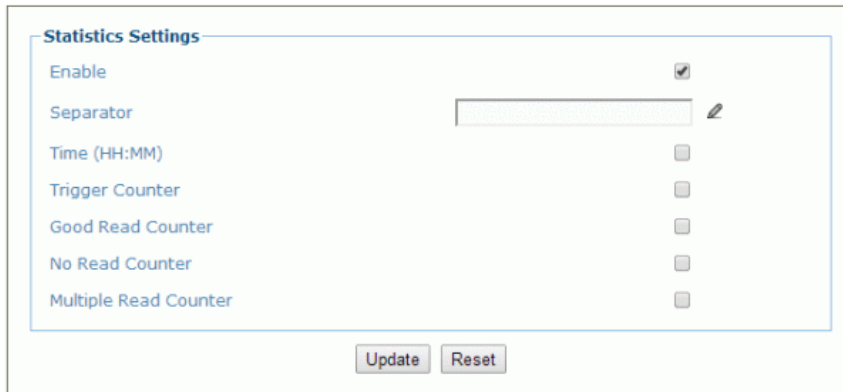

2. Enter the appropriate information in the form described below:

Field name	Action/definition
------------	-------------------

Release Select the check box to display and edit statistic message options. The options depend on the messages, as shown below:

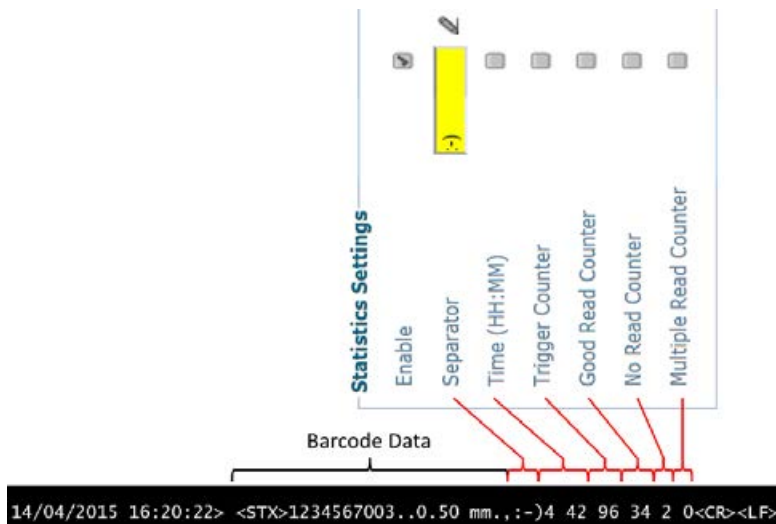

Separator Click to activate the **Text entry tool** and create a **separator** in the text field provided. **Separator** strings (up to 32 bytes) can be created and will be inserted between the last item in the Data field and the first item in the Statistics field.



NOTE: a fixed <space> character separates all items within the Statistics field.

Click **Submit** to adopt your text in the original window text field or click **Cancel** to return to the original window without transferring text.

Time	Select the check box to include the time counter in the statistical message, reporting the time elapsed in hours and minutes (H MM) since the last hardware reset.
Trigger counter	Select the check box to report the total number of trigger sessions (reading phases) since the last hardware reset.
Good read counter	Select the check box to report the total number of good reads since the last hardware reset.
No read counter	Select the check box to report the total number of no reads since the last hardware reset.
Multiple read counter	Select the check box to report the total number of multiple reads since the last hardware reset.

3. When you have finished making changes, click **Update** to save or click **Reset** to revert to the previously saved values.

Modify settings | Global settings | Messaging | Protocol index

Use the **Protocol index** window to configure the protocol index parameters. The protocol index allows the host to transmit a string that it has associated to a package contained within the tracking area.

It is possible to manage several different protocol index messages (one per available communication interface) within the same reading phase (for the same package). If more than one index message is received on the same communication interface, only the last one will be accepted.

These strings will be received by the BCL 900i master or MSC 900 and included in its output message in the following order:

1. Built-in Ethernet user socket 1
2. Built-in Ethernet user socket 2
3. Built-in Ethernet user socket 3
4. Auxiliary serial port
5. Main serial port

The general output format is: <header>Index1<data packet separator>...IndexN<data packet separator>Standard Message<terminator>

The index field has the following format: <index header>Index Message<index terminator>



NOTE: this parameter is only available for scanners configured as **Standalone** or as **Master** device when working in **Online** or **PackTrack** operating modes.

In **Online** operating mode, the protocol index must arrive during the active reading phase otherwise it will be discarded.

- If the "Distance from Protocol Index to Trigger Line" parameter is 0, the protocol index must arrive during the active reading phase otherwise it will be discarded.

In **PackTrack** operating mode:



- If the "Distance from Protocol Index to Trigger Line" parameter is not 0, the protocol index will arrive at the specified distance.

To edit the protocol index settings:

1. In the menu tree under Modify Settings, navigate to Global Settings | Messaging | Protocol Index. The Protocol Index window opens.

2. Enter the appropriate information in the form described below:

Field name	Action/definition
Protocol index enable	Select the check box to display and edit Protocol index options.
Use main serial port	Select Disable , Enable without request message or Enable with request message from the drop-down list. <ul style="list-style-type: none"> • Disable: the selected communication channel is not used for transmission of the protocol index string. • Enable without request message: the host sends the protocol index string autonomously on the selected communication channel. • Enable with request message: the host waits for the protocol index request message sent by the scanner when the trigger detects the presence of a package, before transmitting the protocol index string associated with the package itself on the selected communication channel.
Header	Click to activate the Text entry tool and create a header (up to 128 bytes) to be defined and transmitted as a block preceding the protocol index string sent by the host. Use characters from NUL (00H) to (7EH). Click Submit to adopt your text in the original window text field or click Cancel to return to the original window without transferring text.

Terminator	<p>Click  to activate the Text entry tool and create a terminator to be defined and transmitted as a block following the protocol index string sent by the host. Use characters from NUL (00H) to (7EH).</p> <p>Click Submit to adopt your text in the original window text field or click Cancel to return to the original window without transferring text.</p>
Protocol index length	<p>Select Length in message, Variable length or a length of 3 through 12 from the drop-down list.</p> <ul style="list-style-type: none"> • Length in message: the first byte of the scanner output message indicates the length of the protocol index string sent by the host. • Variable length: the length of the protocol index string sent by the host is variable. • 3...12: the protocol index string has a fixed length from 3 to 12 characters.
No index char	<p>Click  to activate the Text entry tool and create a no index character. Click Submit to adopt your text in the original window text field or click Cancel to return to the original window without transferring text.</p>
Protocol index request message	<p>Click  to activate the Text entry tool and create a protocol index request message. Click Submit to adopt your text in the original window text field or click Cancel to return to the original window without transferring text.</p>
Distance from the protocol index to the trigger line (mm)	<p>Enter a distance in millimeters in the field provided.</p> <p>When the Use main serial port parameter of the selected interface port is set to Enable without request message, this parameter specifies the distance from the trigger line (i.e. presence sensor) to the expected receiving point of the protocol index, measured in mm. If 0 is set, the protocol index must arrive during the active reading phase otherwise it will be discarded.</p>
Use aux serial port / user socket n	<p>Select Disable, Enable without request message or Enable with request message from the drop-down list. Then enter the parameters as described for Use main serial port above.</p>

- When you have finished making changes, click **Update** to save or click **Reset** to revert to the previously saved values.

Modify settings | Global settings | Messaging | Pass-Thru

Use the Pass-Thru window to pass a message received on ANY port (serial or user socket connection) to any other port(s).

Applications can also be implemented to connect a device such as a hand-held reader to any serial or network port for additional manual code reading capability.

When using Pass-Thru operating mode, follow these programming notes:

- When using serial ports: Program the receiving port with respect to the baud rate, data bits, stop bits and parity, in the same way as the device sending the data.
- The termination string must be configured in the same way as the message terminator on the device sending the data. The terminator will be forwarded with the message.

To edit the pass-thru settings:

1. In the menu tree under **Modify settings**, navigate to **Global settings | Messaging | Pass-Thru**. The Pass-Thru window opens.

Pass-Thru Settings

Source - Main Serial Port

String Length

Termination String

Destination

Aux Serial Port User Socket 1 User Socket 2

User Socket 3 User Socket 4 User Socket 5

User Socket 6

Source - Aux Serial Port

Source - User Socket 1

Source - User Socket 2

Source - User Socket 3

Source - User Socket 4

Source - User Socket 5

Source - User Socket 6

2. Enter the appropriate information in the form described below:

Field name	Action/definition
Source	Select the check box(es) to the right of the Main serial port , Aux serial port or numbered User socket you want to modify.
String length	Enter the maximum length of the expected string to be received. If the string is longer than the one expected, it will be discarded.
Termination string	Click  to activate the Text entry tool to define the characters terminating the expected string. Click Submit to adopt your text in the original window text field or click Cancel to return to the original window without transferring text.
Destination	Select the check box next to the destination(s) to be used for the pass-thru.

3. When you have finished making changes, click **Update** to save or click **Reset** to revert to the previously saved values.

Modify settings | Global settings | Messaging | Diagnostics messages

Use the **Diagnostic messages** window to select the parameters for managing diagnostic message transmission by the **Stand alone** or **Master scanner**.

To edit the diagnostic message settings:

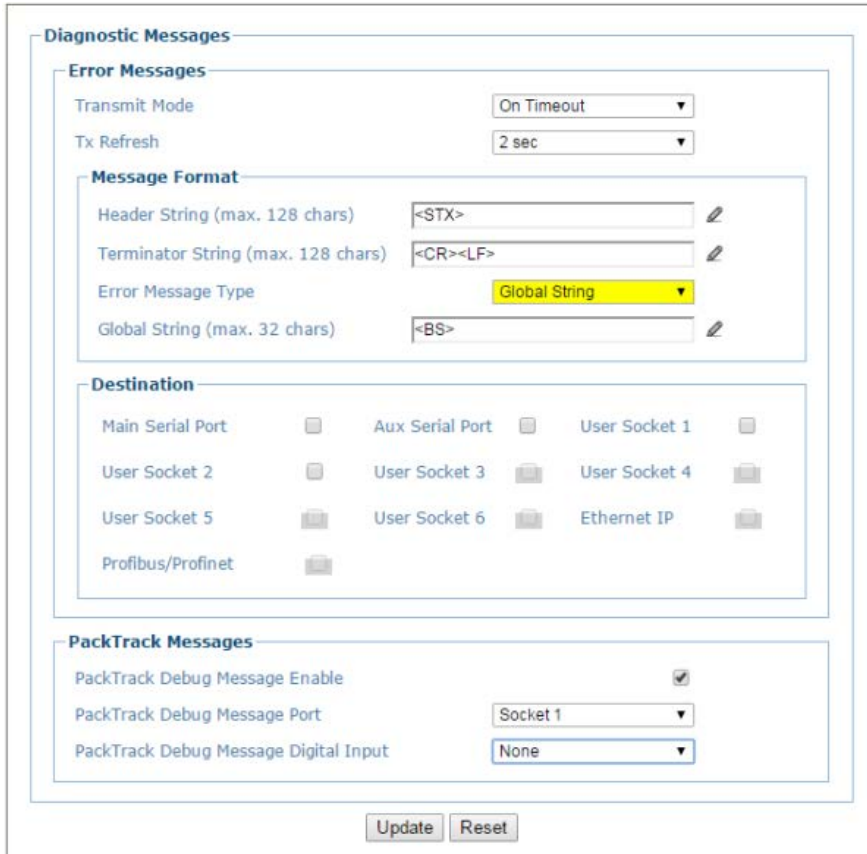

1. In the menu tree under **Modify settings**, navigate to **Global settings | Messaging | Diagnostic messages**. The Diagnostic messages window opens.

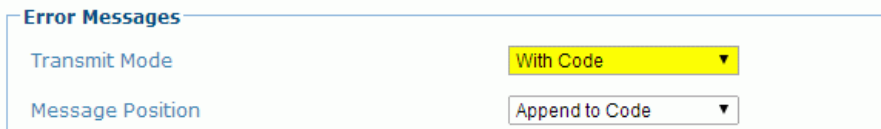

2. Enter the appropriate information in the form described below:

Field name	Action/definition
Transmit Mode	Select On timeout or With code from the drop-down list. The diagnostic message can be transmitted to the system by the Stand alone or Master bar code scanner either asynchronously (at programmed intervals) or synchronously with the code.
Tx refresh	Select a TX refresh rate in seconds or minutes from the drop-down list to define the time interval in which the diagnostic messages will be transmitted if Tx mode is "asynchronous" (On Timeout).
Message position	Select Append to code or Replace code from the drop-down list. If Transmit mode is "synchronous" (With Code), the diagnostic messages will be transmitted on the same interface used for code transmission. This selection determines whether the messages replace the code or are appended to it.



Message format	
Header string	<p>Click  to activate the Text entry tool to define the header string (up to 128 characters) as a block preceding the diagnostic message. Use characters from NUL (00H) to (7EH).</p> <p>Click Submit to adopt your text in the original window text field or click Cancel to return to the original window without transferring text.</p>
Termination string	<p>Click  to activate the Text entry tool to define the termination string (up to 128 characters) as a block following the diagnostic message. Use characters from NUL (00H) to (7EH).</p> <p>Click Submit to adopt your text in the original window text field or click Cancel to return to the original window without transferring text.</p>
Error message type	Select Numeric or Global string from the drop-down list to define how the message will be sent.
Global string (max. 32 chars)	<p>Click  to activate the Text entry tool to define the Global string message (up to 32 bytes) that will be sent as a diagnostic message for any detected diagnostic error.</p> <p>Click Submit to adopt your text in the original window text field or click Cancel to return to the original window without transferring text.</p>
Destination	Select the check box next to the destination(s) to be used for the diagnostic messages.
PackTrack messages	
PackTrack debug message enable	Select the check box to enable debug messages for PackTrack. If selected, this parameter allows the transmission of messages concerning operation of the system.
PackTrack debug message port	Select Main serial , Aux serial or Socket n from the drop-down list. The debug message will be transmitted through the selected port.
PackTrack debug message digital input	Select None , Trigger (input 1) , Aux (input 3) or I/O 4 (input 4) from the drop-down list. This selection defines which digital input will be used to trigger debug message transmission.

3. When you have finished making changes, click **Update** to save or click **Reset** to revert to the previously saved values.

4.5.7 Modify settings | Global settings | Digital I/O

Use the **Digital I/O** window to configure the digital inputs and outputs for your bar code scanning system.

To edit the digital I/O settings:

1. In the menu tree under **Modify settings**, navigate to **Global settings | Diagnostics**. The Digital I/O window opens.

2. Enter the appropriate information in the form described below:

Field name	Action/definition
Digital input lines	

Trigger (input 1) active level Select **Active closed** or **Active open** from the drop-down list.

- **Active closed:** input 1 is active when current flows through the (IN1) EXT_TRIG pins.
- **Active open:** input 1 is active when there is no current flowing through the (IN1) EXT_TRIG pins.



NOTE: this parameter setting is not valid if the input has already been defined in **Online** or **PackTrackms_gs_operating_mode_htm** operating modes.

Aux active level (input 3)	<p>Select Active closed or Active open from the drop-down list.</p> <ul style="list-style-type: none"> • Active closed: input 3 is active when current flows through the IN3 pins. • Active open: input 3 is active when there is no current flowing through the IN3 pins. <p> NOTE: this parameter setting is not valid if the input has already been defined in Online or PackTrackms_gs_operating_mode_htm operating modes.</p>
-----------------------------------	--

Digital output lines

Select digital output number to view/modify	From the drop-down list, select the number of the output you want to view or modify.
--	--

Digital output *n*

Use digital output <i>n</i>	Select Local , Ethernet/IP or Profibus/Profinet from the drop-down list.
------------------------------------	---

Digital output <i>n</i> line state	<p>Select Normally open or Normally closed from the drop-down list.</p> <p>Each output can be represented with an NPN transistor; this transistor acts like a switch: so, when the transistor is OFF, it acts like a switch in the OPEN state. Conversely, when the transistor is ON, it acts like a switch in the CLOSED state.</p> <ul style="list-style-type: none"> • Normally open: the idle state of the output line is "open", i.e. the NPN transistor is OFF (like an open switch). When the output is activated, the transistor switches ON (like a closed switch). • Normally closed: the idle state of the output line is "closed", i.e. the NPN transistor is ON (like a closed switch). When the output is activated, the transistor switches OFF (like an open switch).
---	--

Activation

Primary activation event	<p>Select a Primary activation event from the drop-down list (see below).</p> <ul style="list-style-type: none"> • None: the output is always in line state. • Complete read: the event occurs if all selected codes are read. • Partial read: the event occurs if fewer than the selected codes are read. • No read: the event occurs if no code is read. • Trigger on: the event occurs when a start event takes place starting the reading phase. • Trigger off: the event occurs when a stop event takes place ending the reading phase. • Multiple read: the event occurs if a code is read more than once consecutively. • Right/match: the event occurs if a code is successfully decoded and matches the match code (verifier code). • Wrong/no match: the event occurs if a code is successfully decoded but does not match the match code (verifier code).
---------------------------------	---

Secondary activation event	<p>Select a Secondary (alternate) activation event from the drop-down list (see below).</p> <ul style="list-style-type: none"> • None: the output is always in line state. • Complete read: the event occurs if all selected codes are read. • Partial read: the event occurs if fewer than the selected codes are read. • No read: the event occurs if no code is read. • Trigger on: the event occurs when a start event takes place starting the reading phase. • Trigger off: the event occurs when a stop event takes place ending the reading phase. • Multiple read: the event occurs if a code is read more than once consecutively.
-----------------------------------	---

- **Right/match:** the event occurs if a code is successfully decoded and matches the match code (verifier code).
- **Wrong/no match:** the event occurs if a code is successfully decoded but does not match the match code (verifier code).

Activate on error Select **Disable** or **Enable** from the drop-down list. If this parameter is enabled, the output will activate when a diagnostic error message is sent.



NOTE: if this parameter is used, all other activation events should be set to **None**.

Deactivation

Primary deactivation event Select a **Primary deactivation event** from the drop-down list (see below).

- **None:** a deactivation event is NOT defined.
- **Timeout:** indicates the maximum duration of the output pulse. If this item is selected, the "Deactivation Timeout" text field is displayed.
- **Trigger on:** the event occurs when a start event takes place starting the reading phase.
- **Trigger off:** the event occurs when a stop event takes place terminating the reading phase.

Secondary deactivation event Select a **Secondary (alternate) deactivation event** from the drop-down list (see below).

- **None:** a secondary deactivation event is NOT defined.
- **Trigger on:** the event occurs when a start event takes place starting the reading phase.
- **Trigger off:** the event occurs when a stop event takes place terminating the reading phase.

Deactivate on clear error Select **Disable** or **Enable** from the drop-down list. If this parameter is enabled, the output will deactivate when the error is no longer present.

Deactivation timeout Enter the maximum duration of the output pulse in the text field provided. Enter a value from **40** to **15000 milliseconds**.

3. When you have finished making changes, click **Update** to save or click **Reset** to revert to the previously saved values.

4.5.8 Modify settings | Global settings | Diagnostics

Use the **Diagnostics** window to configure the digital inputs and outputs for your bar code scanning system.

To edit the diagnostics settings:

1. In the menu tree under **Modify settings**, navigate to **Global settings | Diagnostics**. The Diagnostics window opens.

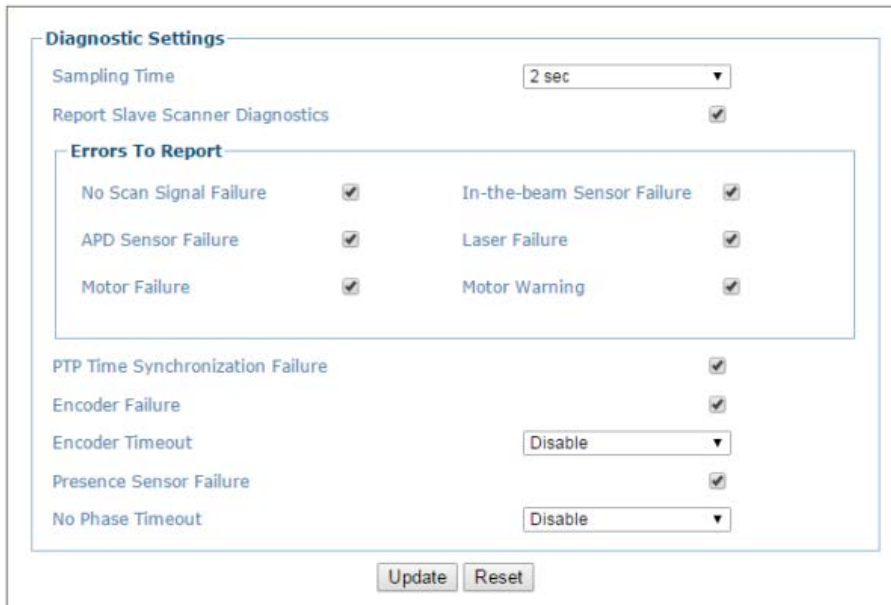

2. Enter the appropriate information in the form described below:

Field name	Action/definition
Sampling Time	Select a sampling time in seconds or minutes from the drop-down list. This selection indicates the time between system diagnostic queries.
Report slave scanner diagnostics	Select the check box if diagnostic information from the slave scanners in the system is to be reported.
Errors to report	Select the check box next to each error type the system should report.
PTP time synchronization failure	Select the check box if PTP (Precision Time Protocol) time synchronization errors are to be reported.
Encoder failure	Select the check box if encoder errors (rotation encoder errors) are to be reported.
Encoder timeout	Select Disable or a time interval in seconds or minutes from the drop-down list. If a time interval is selected, a jammed encoder will report an error after the selected interval.
Presence sensor failure	Select the check box if presence sensor failure errors are to be reported.
No phase timeout	Select Disable or a time interval in seconds or minutes from the drop-down list. If a time interval is selected, a jammed sensor will report an error after the selected interval.

3. When you have finished making changes, click **Update** to save or click **Reset** to revert to the previously saved values.

4.5.9 Modify settings | Global settings | Energy saving







Use the **Energy saving** window to activate/deactivate the energy saving function. In particular, it allows network scanner motors and lasers to be switched on or off according to specific conditions. It is recommended to use this parameter e.g. if the conveyor is stopped for a lengthy period.

To view and edit the energy saving settings:

1. In the menu tree under Modify settings, navigate to Global settings | Energy saving. The Energy saving window opens.

2. Enter the appropriate information in the form described below:

Field name	Action/definition
Energy saving configuration	Select the check box to display the Energy saving configuration options.
Use encoder for	Select None , Deactivation , Activation or Activation and deactivation from the drop-down list. This parameter allows definition of the function that is to be performed by an encoder: <ul style="list-style-type: none"> • None: no function is performed by the digital input. • Deactivation: the digital input is used to deactivate the energy saving function. The motors and lasers of all network scanners are switched on. • Activation: the digital input is used to activate the energy saving function. The motors and lasers of all network scanners are switched off. • Activation and deactivation: the digital input is used to both activate and deactivate the energy saving function. The motors and lasers of all network scanners are switched on/off.
Activation encoder timeout	Select a minute value from the drop-down list. This parameter is available only when the encoder is used for activation of the energy saving function. If the encoder is stopped for longer than the programmed timeout, the energy saving function will be activated.

Deactivation encoder timeout	Select a second or minute value from the drop-down list. This parameter is available only when the encoder is used for deactivation of the energy saving function. If the encoder runs for at least the programmed timeout, the energy saving function will be deactivated.
Use digital input for	<p>Select None, Deactivation, Activation or Activation and deactivation from the drop-down list. This parameter allows definition of the function that is to be performed by a digital input:</p> <ul style="list-style-type: none"> • None: no function is performed by the digital input. • Deactivation: the digital input is used to deactivate the energy saving function. The motors and lasers of all network scanners are switched on. • Activation: the digital input is used to activate the energy saving function. The motors and lasers of all network scanners are switched off. • Activation and deactivation: the digital input is used to both activate and deactivate the energy saving function. The motors and lasers of all network scanners are switched on/off.
Select digital input	Select a digital input from the drop-down list. This parameter defines the digital input to be used for activating/deactivating the energy saving function.
Select input type	Select Edge or Level from the drop-down list.
Use main serial port for	<p>Select None, Deactivation, Activation or Activation and deactivation from the drop-down list. This parameter allows definition of the function that is to be performed by the main serial port:</p> <ul style="list-style-type: none"> • None: no function is performed by the digital input. • Deactivation: the digital input is used to deactivate the energy saving function. The motors and lasers of all network scanners are switched on. • Activation: the digital input is used to activate the energy saving function. The motors and lasers of all network scanners are switched off. • Activation and deactivation: the digital input is used to both activate and deactivate the energy saving function. The motors and lasers of all network scanners are switched on/off.
Header	<p> NOTE: this parameter is available only when a communication channel has been selected to perform a specific function.</p> <p>Click  to activate the Text entry tool and create a Header (up to 128 bytes) to define a header (1 byte) and transmit it as a block preceding the activation/deactivation string sent to a master or stand-alone scanner. Use characters from NUL (00H) to (7EH). Click Submit to adopt your text in the original window text field or click Cancel to return to the original window without transferring text.</p>
Terminator	<p> NOTE: this parameter is available only when a communication channel has been selected to perform a specific function.</p> <p>Click  to activate the Text entry tool and create a Terminator to define a terminator (1 byte) and transmit it as a block following the activation/deactivation string sent to the master or stand-alone scanner. Use characters from NUL (00H) to (7EH). Click Submit to adopt your text in the original window text field or click Cancel to return to the original window without transferring text.</p>
Activation string	<p> NOTE: this parameter is available only when a communication channel has been selected to perform the Activation or Activation and deactivation function.</p> <p>Click  to activate the Text entry tool and create a string that defines the characters to be transmitted within the output message to activate the energy saving function. Click Submit to adopt your text in the original window text field or click Cancel to return to the original window without transferring text.</p>

Deactivation string

NOTE: this parameter is available only when a communication channel has been selected to perform the **Deactivation** or **Activation and deactivation** function.

Click  to activate the **Text entry tool** and create a character string to be transmitted within the output message to deactivate the **energy saving** function. Click **Submit** to adopt your text in the original window text field or click **Cancel** to return to the original window without transferring text.

Use Aux serial port for

Select **None**, **Deactivation**, **Activation** or **Activation and deactivation** from the drop-down list. This parameter allows definition of the function that is to be performed by the aux serial port:

- **None:** no function is performed by the digital input.
- **Deactivation:** the digital input is used to deactivate the energy saving function. The motors and lasers of all network scanners are switched on.
- **Activation:** the digital input is used to activate the energy saving function. The motors and lasers of all network scanners are switched off.
- **Activation and deactivation:** the digital input is used to both activate and deactivate the energy saving function. The motors and lasers of all network scanners are switched on/off.

Header

NOTE: this parameter is available only when a communication channel has been selected to perform a specific function.

Click  to activate the **Text entry tool** and create a **Header** (up to 128 bytes) to define a header (1 byte) and transmit it as a block preceding the activation/deactivation string sent to a master or stand-alone scanner. Use characters from NUL (00H) to (7EH). Click **Submit** to adopt your text in the original window text field or click **Cancel** to return to the original window without transferring text.

Terminator

NOTE: this parameter is available only when a communication channel has been selected to perform a specific function.

Click  to activate the **Text entry tool** and create a **Terminator** to define a terminator (1 byte) and transmit it as a block following the activation/deactivation string sent to the master or stand-alone scanner. Use characters from NUL (00H) to (7EH). Click **Submit** to adopt your text in the original window text field or click **Cancel** to return to the original window without transferring text.

Activation string

NOTE: this parameter is available only when a communication channel has been selected to perform the **Activation** or **Activation and deactivation** function.

Click  to activate the **Text entry tool** and create a string that defines the characters to be transmitted within the output message to activate the **energy saving** function. Click **Submit** to adopt your text in the original window text field or click **Cancel** to return to the original window without transferring text.

Deactivation string

NOTE: this parameter is available only when a communication channel has been selected to perform the **Deactivation** or **Activation and deactivation** function.

Click  to activate the **Text entry tool** and create a character string to be transmitted within the output message to deactivate the **energy saving** function. Click **Submit** to adopt your text in the original window text field or click **Cancel** to return to the original window without transferring text.

User socket n for

Select **None**, **Deactivation**, **Activation** or **Activation and deactivation** from the drop-down list. This parameter allows definition of the function that is to be performed by a numbered socket:

- **None:** no function is performed by the digital input.
- **Deactivation:** the digital input is used to deactivate the energy saving function. The motors and lasers of all network scanners are switched on.
- **Activation:** the digital input is used to activate the energy saving function. The motors and lasers of all network scanners are switched off.
- **Activation and deactivation:** the digital input is used to both activate and deactivate the energy saving function. The motors and lasers of all network scanners are switched on/off.

Header

NOTE: this parameter is available only when a communication channel has been selected to perform a specific function.

Click  to activate the **Text entry tool** and create a **Header** (up to 128 bytes) to define a header (1 byte) and transmit it as a block preceding the activation/deactivation string sent to a master or stand-alone scanner. Use characters from NUL (00H) to (7EH). Click **Submit** to adopt your text in the original window text field or click **Cancel** to return to the original window without transferring text.

Terminator

NOTE: this parameter is available only when a communication channel has been selected to perform a specific function.

Click  to activate the **Text entry tool** and create a **Terminator** to define a terminator (1 byte) and transmit it as a block following the activation/deactivation string sent to the master or stand-alone scanner. Use characters from NUL (00H) to (7EH). Click **Submit** to adopt your text in the original window text field or click **Cancel** to return to the original window without transferring text.

Activation string

NOTE: this parameter is available only when a communication channel has been selected to perform the **Activation** or **Activation and deactivation** function.

Click  to activate the **Text entry tool** and create a string that defines the characters to be transmitted within the output message to activate the **energy saving** function. Click **Submit** to adopt your text in the original window text field or click **Cancel** to return to the original window without transferring text.

Deactivation string

NOTE: this parameter is available only when a communication channel has been selected to perform the **Deactivation** or **Activation and deactivation** function.

Click  to activate the **Text entry tool** and create a character string to be transmitted within the output message to deactivate the **energy saving** function. Click **Submit** to adopt your text in the original window text field or click **Cancel** to return to the original window without transferring text.

- When you have finished making changes, click **Update** to save or click **Reset** to revert to the previously saved values.

4.5.10 Modify settings | Global settings | HMI settings (Human-machine interface)

Use the **HMI settings** window to configure some aspects of the scanner LEDs and HMI interface.

To view and edit the HMI settings:

1. In the menu tree under **Modify settings**, navigate to **Global settings | HMI settings**. The HMI settings window opens.

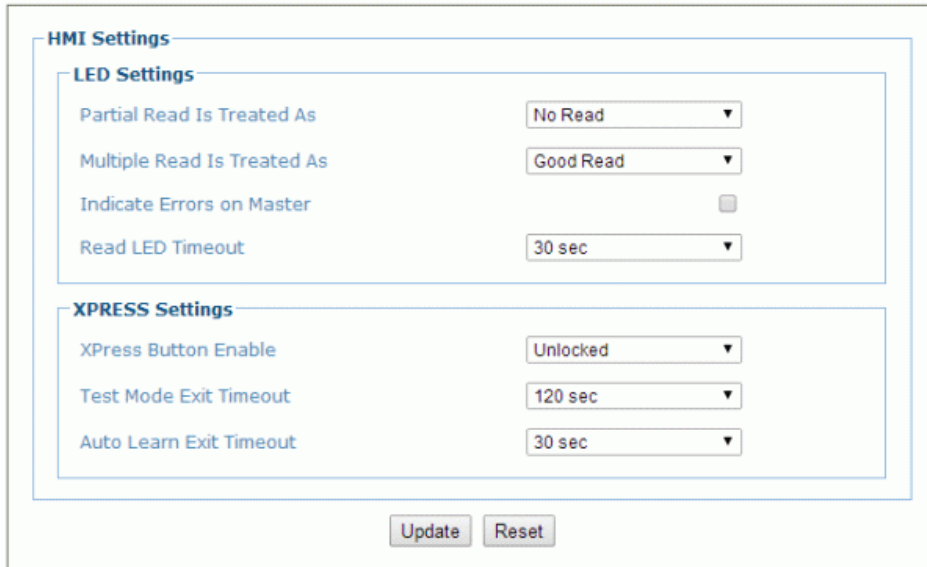

2. Enter the appropriate information in the form described below:

Field name	Action/definition
LED settings	
Partial read is treated as	Select No read or Good read from the drop-down list.
Multiple read is treated as	Select No read or Good read from the drop-down list.
Indicate errors on master	Select the check box to indicate errors from any scanner on the master scanner's LEDs.
Read LED timeout	Select Disable or a second value from the drop-down list.
XPRESS settings	
XPress button enable	Select Unlocked , Partially locked or Locked from the drop-down list. <ul style="list-style-type: none"> • Unlocked: when selected, the XPress button is active • Locked: when selected, the XPress button is inactive
Test mode exit timeout	Select Disable or a second value from the drop-down list. This indicates how long the scanner will stay in Test mode.
Auto learn exit timeout	Select Disable or a second value from the drop-down list. This indicates how long the scanner will stay in Learn mode.

3. When you have finished making changes, click **Update** to save or click **Reset** to revert to the previously saved values.

4.6 DEVICE SETTINGS

Use the options in the **Device settings** menu tree during initial mounting and setup to view device information and configure your **BCL 900i bar code scanner(s)**. If multiple scanners are used in a tunnel or array, each named scanner will be listed under "Device settings" with the sub-menus **Device info**, **Mounting** and **Options**. If necessary, you can make modifications to the configuration later using the same menu options. This includes:

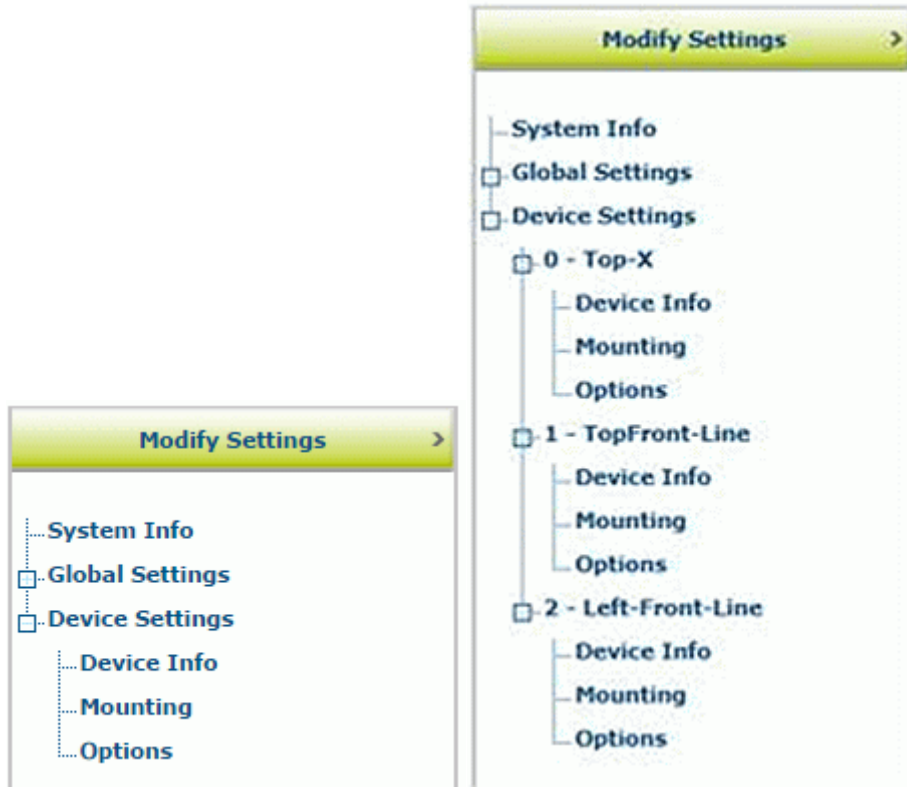

Single-scanner menu trees

Tunnel/array menu tree

4.6.1 Device settings | Device name | Device info

Use the **Device info** window to call up information about each device in the system, e.g. description, serial number and address.

To view the "Device info" window:

1. In the menu tree under **Modify settings**, navigate to **Device settings | Device name (if applicable) | Device info**. The **Device info** window opens.



NOTE: if more than one device belongs to the scanning system, the device name will be listed in the menu tree after the "Device settings" level.

Device Information

Description: Master

Device Address: 0

Serial Number: C14C03507

MAC Address: 0007BE00EF8A

Model Name: DS8110-Custom

Model Number: 19

Hardware Release: 65535

Number Legs: 1

Number Lasers: 2

Number Facets: 7

Scan Rate (scans/sec): 1000

Software Versions

Software Version: ARM_release_v0_8_5_5

DSP Version: Decoder_release_v1_8_14_1

FPGA Version: XLC_v8_28_0_0

2. You can view the following scanner information:

Field name	Definition
Description	Displays the scanner description entered in the System Info window.
Device_Address	Displays the system address.
Serial number	Displays the serial number sent by the device.
MAC address	Displays the MAC (media access control) address of the device.
Model name	Displays the model name sent by the device.
Model number	Displays the model number sent by the device.

Hardware release Displays the hardware release number of the device.

Number legs Displays the number of laser legs (beams) produced by the device. Each BCL 900i (line) scanner has 1 leg.

Number lasers Displays the number of lasers used by the scanner.

Number facets Displays the number of facets in the mirror wheel.

Scan rate (scans/s) Displays the scans/per second achieved by the scanner.

Software versions

Software version Displays the currently installed version of the **ARM** (anonymizing relay monitor) software.

DSP version Displays the currently installed version of the decoder software.

FPGA version Displays the currently installed version of the **FPGA (field-programmable gate array)** software.

4.6.2 Device settings | Device name | Mounting

Use the **Mounting** window to configure some aspects of the scanner LEDs and HMI interface.

To view and edit the mounting settings:

1. In the menu tree under **Modify settings**, navigate to **Device settings | Device name (if applicable) | Mounting**. The Mounting window opens.



NOTE: if more than one device belongs to the scanning system, the device name will be listed in the menu tree after the "Device settings" level.

PackTrack Calibration Coefficients	
Y Adjustment	0 mm
Calibration Item 1	0.738934
Calibration Item 2	0.093086
Calibration Item 3	443.324799
Calibration Item 4	-0.736568
Calibration Item 5	0.152025
Calibration Item 6	1157.441406
Calibration Item 7	-0.032004
Calibration Item 8	-0.997090
Calibration Item 9	1519.108276

2. Enter the appropriate information in the form described below:

Field name	Definition
------------	------------

Calibration method Select **Specify mounting** or **PackTrack calibration** from the drop-down list. If **Specify mounting** is selected, you must manually enter the required data. If **PackTrack calibration** is selected, use the wizard to enter most of the data automatically.



NOTE: at the time of release of this manual, **PackTrack calibration** was the only option available.

PackTrack calibration

PackTrack calibration wizard	Click Launch wizard to open the PackTrack calibration wizard . See section 5.6 <i>PackTrack</i> for the complete procedure for using the wizard to set up your bar code scanner.	
Calibration adjustment	Y adjustment	In the field provided, enter the scanner adjustment from the Y axis in millimeters. This is used to make fine adjustments to the tested calibration (see <i>section 5.6</i>).
PackTrack calibration coefficients	Calibration item 1-9 These non-editable fields display the PackTrack calculations.	

3. When you have finished making changes, click **Update** to save or click **Reset** to revert to the previously saved values.

PackTrack calibration wizard

PackTrack is a patented operating mode for **omni-directional reading stations** used to read and correctly assign codes read on different packs when placed in the scanner reading field at the same time.

See section 5.6 **PackTrack** for the complete procedure for using the wizard to set up your bar code scanner.

4.6.3 Device settings | Device name | Options

Use the **Options** window to configure some aspects of the scanner LEDs and HMI interface.

To view and edit the options settings:

1. In the menu tree under **Modify settings**, navigate to **Device settings | Device name (if applicable) | Options**. The **Options** window opens.



NOTE: if more than one device belongs to the scanning system, the device name will be listed in the menu tree after the "Device settings" level.

2. Enter the appropriate information in the form described below:

Field name	Definition
------------	------------

Field of view start angle	Enter the field of view (FOV) start angle in the field provided. This will adjust the FOV start angle to that specified.
----------------------------------	--

In the example below, the original **start angle** of 30° is reduced to 25° degrees when this value is entered.

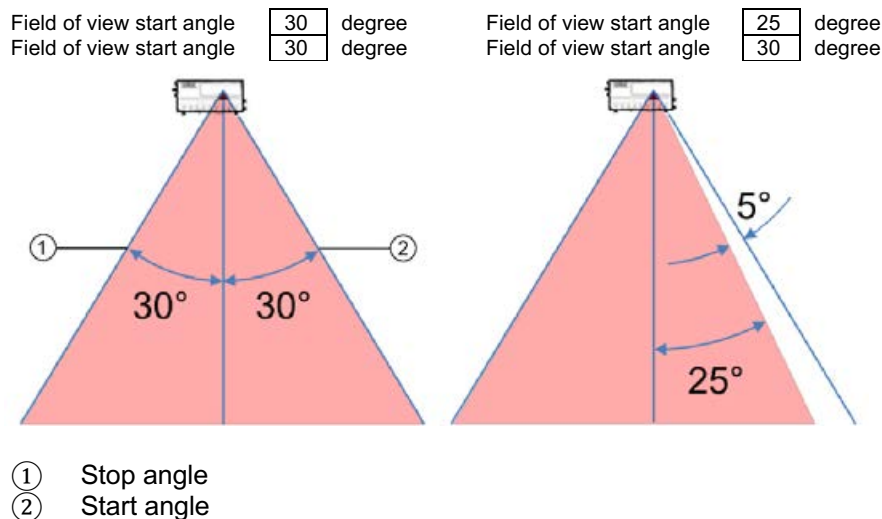



Figure 30: Start/stop angle



NOTE: this option is only available for the BCL 900i scanner.

Field of view stop angle	Enter the field of view (FOV) stop angle in the field provided. This will adjust the FOV stop angle to the value specified.
	 NOTE: this option is only available for the BCL 900i scanner.
Barcode reconstruction	Select the check box to enable code reconstruction technology (CRT) when reading the code. If not selected, standard linear reading mode will be used.
Enable stacked codes	Select the check box to enable code reconstruction when two or more codes (of the same or different symbologies) are stacked one on top of the other with little or no space between them.
Overflow start ratio	Enter the minimum expected width of the bar code starting quiet zone, expressed in number of modules from 1 to 50.
Overflow stop ratio	Enter the minimum expected width of the bar code stopping quiet zone, expressed in number of modules from 1 to 50.

- When you have finished making changes, click **Update** to save or click **Reset** to revert to the previously saved values.

4.7 DIAGNOSIS

Use the **Diagnostics** menu tree options to monitor the performance of your bar code scanning system, to view system messages and to access the online help. The **Diagnostics** window contains the following elements:

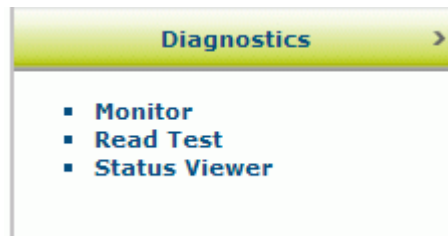

4.7.1 Diagnostics | Monitor

Use the **Diagnostics > Monitor** option as the primary tool to monitor the reader's operation and bar code readability in real-time. Status indicators and vital statistics appear on a single screen, enabling you to effectively and efficiently detect and troubleshoot any problems that may occur.



NOTE: the Monitor is a Java application and requires Java and the appropriate browser plug-in.

To open the Monitor window:

In the menu tree under **Diagnostics**, navigate to **Monitor**. The **Monitor** window opens.

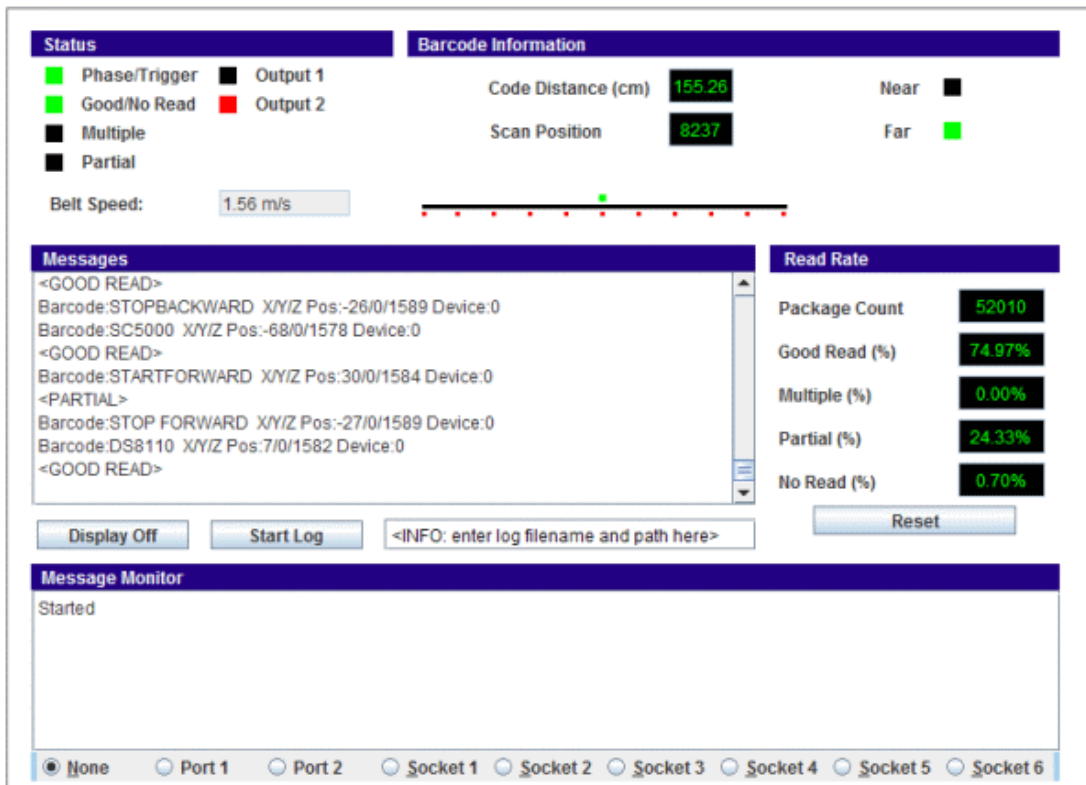

The status indicators in **Diagnostics > Monitor** indicate the following states:

Field	Definition
Status	
Phase/Trigger	GREEN indicates trigger input. The LED is activated upon trigger input irrespective of the trigger source (including software trigger).
Good/No read	GREEN indicates that a good (valid) bar code has been decoded. RED indicates a no-read (or incomplete decode).
Multiple	RED indicates that more codes than desired were read.
Partial	RED indicates a partial read.

Output 1 / Output 2	RED indicates activity on the respective output.
Belt speed	Indicates the current speed of the belt indicated by the encoder (rotation encoder).
Barcode information	
Code distance (cm)	Displays the distance from the laser source to the scanned bar code.
Scan position	Displays the position of the code in the scan line.
Near	GREEN indicates that the bar code has been scanned by the near-focus laser.
Far	GREEN indicates that the bar code has been scanned by the far-focus laser.
Messages	
Messages field	Displays message data being returned by the scanner for each bar code scanned.
Display Off/On	Click to switch the real-time messages off/on.
Start log	Click to create a log file from the time of the click. Enter a filename and path for the log file in the field provided.
Reading rate	
Package count	Displays the number of packages detected since the last reset.
Good read (%)	Displays the number of good bar code reads since the last reset.
Multiple (%)	Displays the number of multiple bar codes detected since the last reset.
Partial (%)	Displays the number of partially read bar codes since the last reset.
No read (%)	Displays the number of no reads (no bar code read on the package) since the last reset.
Reset	Click to reset the above counters.
Message monitor	
Message monitor field	Select the option button next to Port 1, Port 2, Socket 1, Socket 2, Socket 3, Socket 4, Socket 5 or Socket 6 to display messages for the host port concerned. Select the option button next to None to stop displaying messages.

4.7.2 Diagnostics | Read test

Use the "Read test" window to check how well a scanner is operating.

To test operation of a scanner:

1. In the menu tree under **Diagnostics**, navigate to **Read test**. The **Read test** window opens.

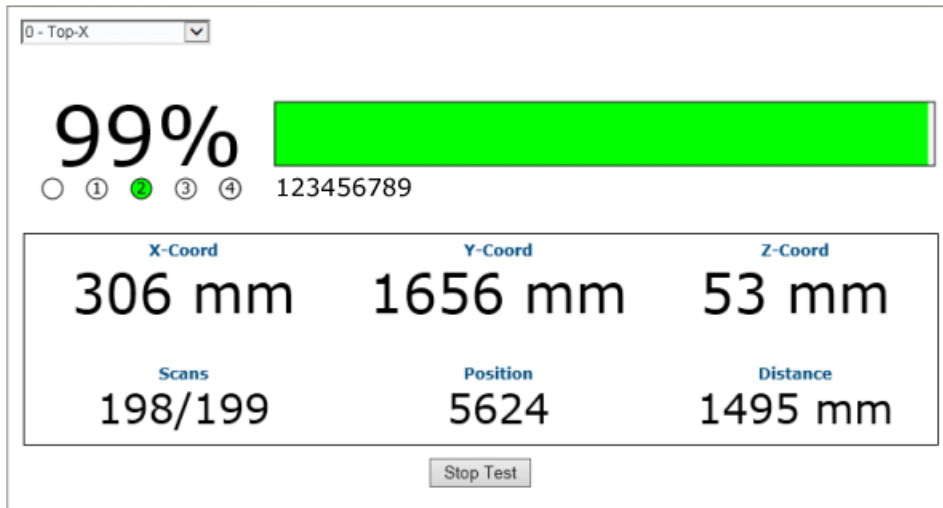

2. If there are multiple scanners in the system, select the scanner to be tested from the drop-down list at the top of the **Read test** window.
3. Click the **Start/Stop test** toggle button to run or stop the real-time performance display of the scanner.

The read test displays the following information:

- **Read rate:** this is the percentage readout and bar at the top of the window, displaying the read rate since the start of the test.
The numbered circle indicators below the read-rate percentage indicate in **GREEN** which of the scanner's lasers is reading the bar code.
The alphanumeric text following the numbered circle indicators is the bar code data.
- **Laser identifiers:** these circles below the read-rate percentage identify the number of lasers in the scan head as well as highlighting in GREEN the laser that is reading the code. In the example above, the scanner has four lasers and laser 2 is identified as reading the code. If the first circle is highlighted in RED, this indicates a NOREAD.
- **XYZ coord:** this displays the real-time coordinates of the bar codes being read.
- **Scans:** displays the number of times the scanner decoded the test bar code out of the number of opportunities it had to decode the test bar code during a test cycle.
- **Position:** displays the position of the bar code in the scan line.
- **Distance:** displays the distance from the laser source to the last bar code read.

4.7.3 Diagnostics | Status viewer

Use the **Status viewer** to check your scanner's health.

To start and use the Status viewer:

1. In the menu tree under "Diagnostics", navigate to "Status viewer". The "Status viewer" window opens.

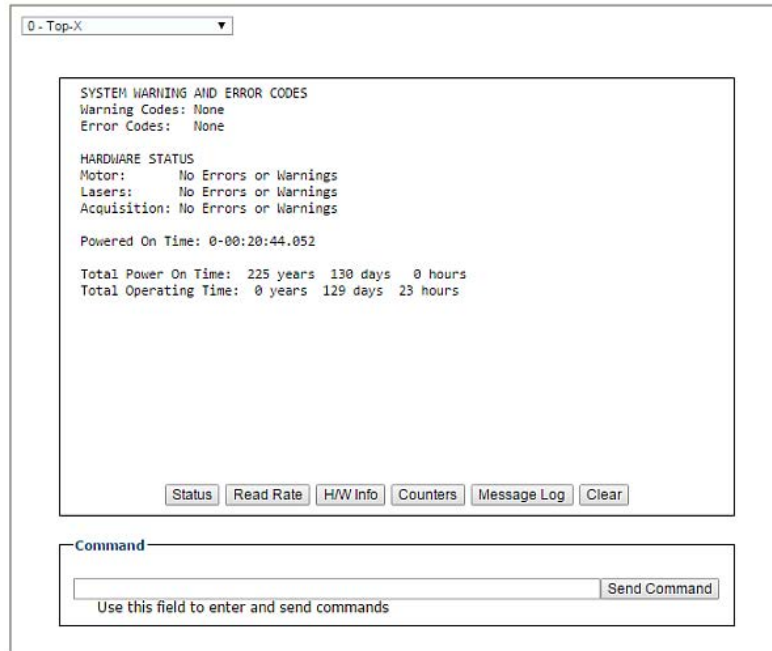

2. Select a device to view from the drop-down list at the top-left corner of the window.
3. Click a button at the bottom of the display window to select the type of information you want to view:
 - **Status:** displays system warnings or errors.

```

SYSTEM WARNING AND ERROR CODES
Warning Codes: None
Error Codes: None

HARDWARE STATUS
Motor:      No Errors or Warnings
Lasers:    No Errors or Warnings
Acquisition: No Errors or Warnings

Total Power On Time: 225 years 172 days 8 hours
Total Operating Time: 0 years 172 days 7 hours

```

- **Read rate:** displays read rate and package count information.

```

READ RATE
Total Packages:      34204
Good Reads:         25086    73%
No Reads:           837      2%
Partial:            8281    24%
Multiple:            0        0%

```

- **H/W Info:** displays information about the selected hardware, e.g. serial number, scans/second, laser information.

```

CONFIGURATION
Model Type:  BCL 900i SM 102
Serial Num:  C14C03507
Mac Address: 00-07-be-00-ef-8a
Num Lasers:  2
Num Legs:    1
Num Facets:  7

CURRENT STATUS
Scan Rate:    1000 scans/sec
Current APD DAC: 469

          Temp      VCC
Laser 1:    40.59 C  3.2790
Laser 2:    40.89 C  3.2722
Logic Board: 39.00 C
APD Board:  41.50 C

```

- **Counters:** displays cumulative data about scans, triggers, errors, and much more.

```

SYSTEM INFO
Scan Rate (scans/sec): 999      Belt Speed (m/s): 1.55
Tach Rate (cnts/sec) : 2429    Belt Speed (ft/min): 306

DECODER COUNTERS
Scan Ints:      14796      DSP Codes:      59214
Triggers:      59548      DSP Triggers:   960
Process L0:    25824      Process L1:     0
Max Elements L0: 310      Max Elements L1: 0
Queue Size:    1          Queue Max:      9
Mem Alloc Err: 0          Memory Full:    0

SCAN DATA EXCEPTION COUNTERS
Missed DMA:    0          Missed QDMA:    0
Xfer Overflow: 0          Xfer Bad Length: 0
ASTRA Seg Err: 0          Invalid Leg No: 0
Low Term Count: 0        High Term Count: 0
Motor Var Cnt: 0

ARM Restarts:  0          DSP Restarts:   0

```

- **Message log:** displays messages logged since the last clear command.

```
0-00:00:00.723: APD Read: DAC/Temp Ref: 243/6400
0-00:00:00.723: APD Read: Gain/Offset/Min/Max/Type: -1/-1/-1/-1/-1
0-00:00:00.725: APD DAC Initialized.
0-00:00:00.852: ADC Configuration Complete.
0-00:00:00.959: Loading FPGA file XLC_v20_0_0.fpga.
0-00:00:03.938: FPGA device id: 4c55.
0-00:00:03.938: FPGA version: 6.0(0).
0-00:00:06.378: Loading DSP file Decoder_release_v1_8_17_0.dsp.
0-00:00:06.678: DSP load complete.
0-00:00:06.678: Scan Engine Started.
0-00:00:06.679: FPGA Buffer Export Task Started
0-00:00:14.664: Motor Speed Threshold set to 0xFFFF.
0-00:00:14.664: FIR Filter Coefficients Loaded.
0-00:00:14.664: Scan FOV set to 88 deg (off=1562 len=21420)
0-00:00:15.263: Ethernet Initialization Complete.
0-00:00:15.263: Web Server Initialization Complete.
0-00:00:16.665: DSP Version 1.8.17 Started.
0-00:00:16.665: Scan Engine Initialized.
0-00:00:16.686: IsAlone=0 IsMaster=0 NumDevices=3
Powered On Time: 0-00:38:22.825
```

4. Click **Clear** to clear the **Message log**.

You can also enter a specific system command in the field provided at the bottom of the window. Click **Send command** to execute.

4.8 UTILITIES

Use the options in the **Utilities** menu tree to backup, restore and update system firmware, or to reboot the scanner. The **Utilities** window contains the following elements:



4.8.1 Utilities | Backup or Restore

Use **Backup or Restore** to save all the settings to the dimensioner and to back up the settings to the backup module and/or a file.

To use the backup or restore functions:

1. In the menu tree under **Utilities**, click **Backup or Restore**. The **Backup or Restore** window opens.

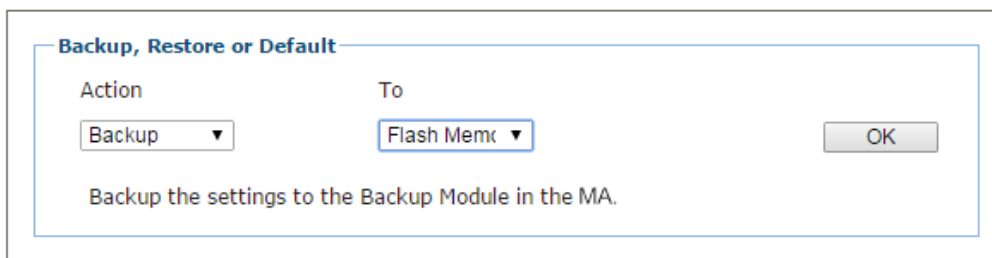

2. From the drop-down lists shown, select an **Action** and a **To/From** option.

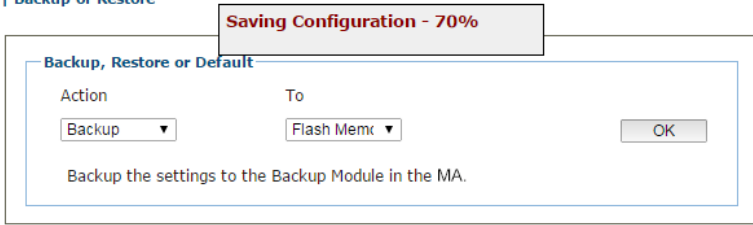
Action	To/From	
Backup	Flash memory	<p>If this option is selected, click OK to save the settings to the backup module in the MA connection unit. An info box displays how far, in percent, the save operation has progressed.</p> <p>Utilities Backup or Restore</p> 
File		<p>If this option is selected, click OK to download the file to your computer. The file can then be saved to an appropriate backup folder.</p>
Restore	Flash memory	<p>If this option is selected, click OK to restore the settings on the backup module in the MA. An info box displays how far, in percent, the restore operation has progressed.</p>

-
- File** If this option is selected, a **Choose file** button is displayed. Click **Choose file** to open a file browser and locate the .txt file with the settings to be restored. When the file has been located and selected, click **OK** to save the file to the device.

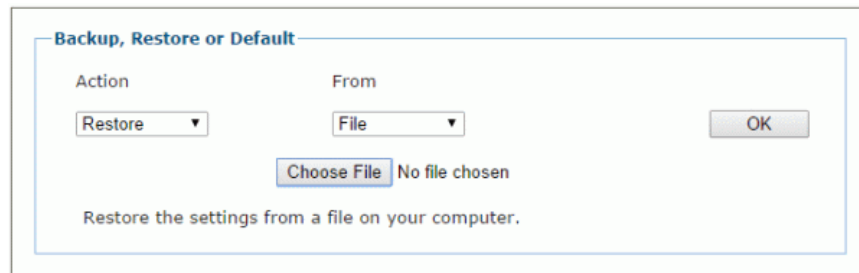

Backup, Restore or Default

Action: Restore ▼ From: File ▼

Choose File No file chosen

Restore the settings from a file on your computer.

OK

-
- Default setting** **Application** If this option is selected, click **OK** to restore the application settings to the factory defaults, except for Ethernet and PackTrack.

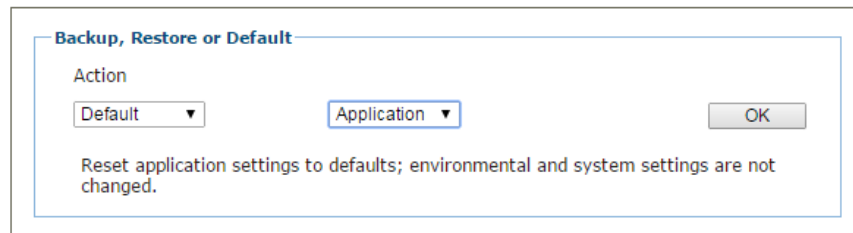

Backup, Restore or Default

Action: Default ▼ From: Application ▼

Reset application settings to defaults; environmental and system settings are not changed.

OK

-
- App and Env** If this option is selected, click **OK** to restore all settings, including Ethernet and PackTrack, to the factory defaults.

-
- All** If this option is selected, click **OK** to **COMPLETELY** reset the scanner to the factory configuration.
-

4.8.2 Utilities | Reboot

Use the **Reboot** window to restart the scanner or system.

To use the reboot function:

1. In the menu tree under **Utilities**, click **Reboot**. The Reboot window opens.

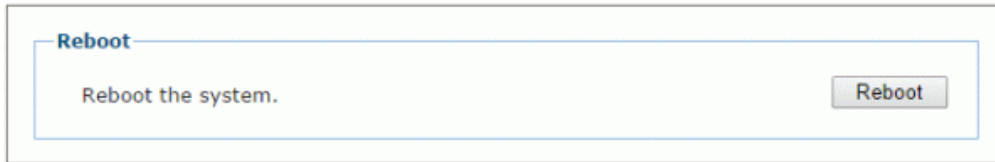

2. Click **Reboot**. A confirmation box appears.

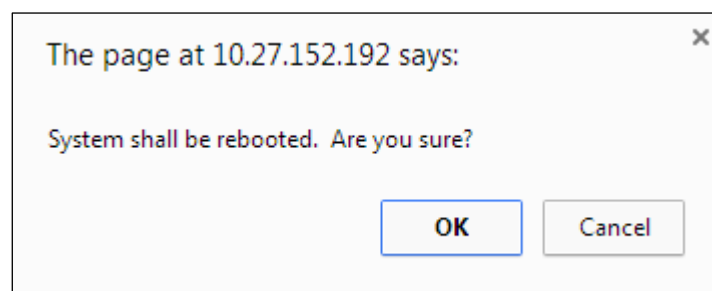

3. Click **OK** to reboot the system, or click **Cancel** to return to the Reboot window without restarting the system.

4.8.3 Utilities | Update firmware

Use **Update firmware** to reload the scanner system firmware.



CAUTION: this function should only be performed under the guidance of Leuze electronic Technical Support.

To extract an image:

1. In the menu tree under **Utilities**, click **Update firmware**. The **Update firmware** window opens.

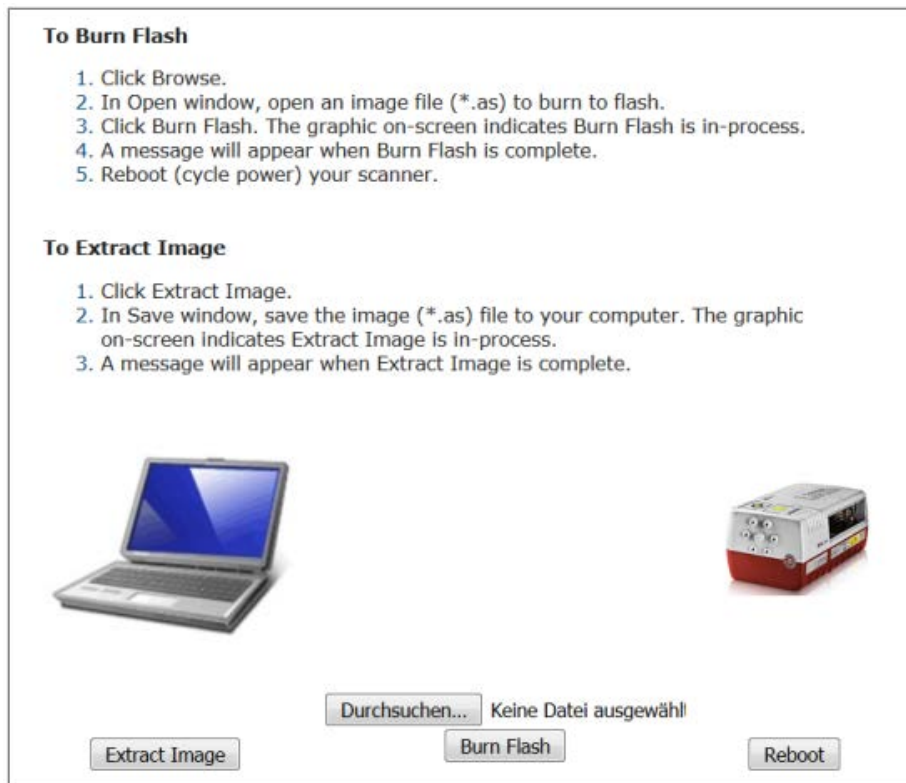

2. Click **Extract image**. A confirmation box appears.

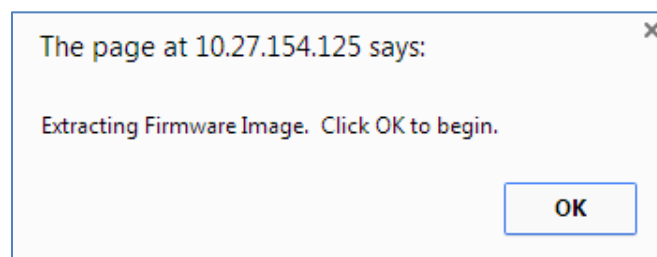

3. Click **OK** to continue.
4. The graphic on the screen indicates that **Extract image** is in progress. A message will appear when **Extract image** is complete.

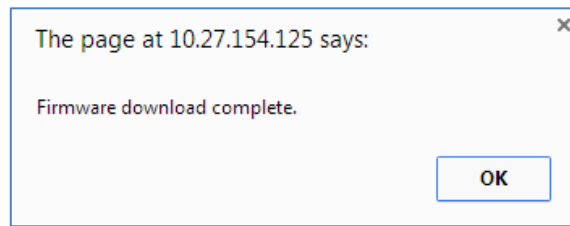
**To burn the flash memory:**

1. Click **Choose file**. In the browser window, select an image file (*.as) to burn to the flash memory.



NOTE: the appearance of these functions may vary from browser to browser.

2. Click **Burn flash**. The graphic on the screen indicates that **Burn flash** is in progress.
3. A message will appear when **Burn flash** is complete.

To reboot the system:

1. Click **Reboot**. A confirmation box appears.

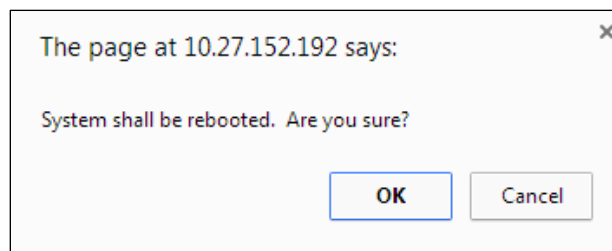

2. Click **OK** to reboot the system, or click **Cancel** to return to the Reboot window without restarting the system.

5 BAR CODE SCANNING FUNCTIONS

This chapter provides details on how the BCL 900i bar code scanning system functions during normal operation. It also helps familiarize the user with the status indicator LEDs, the control panel functions and system setup, and also provides information on how the scanners can be easily and quickly replaced with a new device if necessary.



IMPORTANT: the procedures outlined in this chapter should only be performed by a technician trained by Leuze electronic.

For further information on training, contact us through the Leuze electronic website at www.leuze.com.

5.1 INITIAL COMMISSIONING



NOTE: before starting up or testing the scanner, it must be connected to an MA 900 connection unit or an MSC 900 controller, depending on the system configuration.

On initial power-up, the BCL 900i performs a series of self-diagnostic and LED tests. The complete power-up sequence takes about 20 seconds. When the **READY** LED flashes and turns a steady green, the power-up sequence is complete and the scanner is operational.

5.1.1 Default parameters

The bar code scanners are shipped from the factory with the following defaults:

- Default password: LEUZE
- Control panel buttons enabled
- Code 128 (10-30 characters), Code 39
- IP address HOST 172.27.101.220; setup 192.168.3.100

Perform the following setup procedure using these defaults or configure your bar code scanner with your application's parameters using the user interface.

5.1.2 Checking functions in test mode



NOTE: perform the following test using a bar code that matches the default parameters. A bar code test chart is included in the box with each scanner, and a code from the chart can be used to perform the test.

If the default parameters have been changed, you must enable the control panel buttons and the other default parameters listed.

To quickly check BCL 900i operation:

1. Make sure that the scanner is connected to an MA 900 or MSC 900.
2. Switch on the reader.
3. Press and hold the MODE button until the first two red LEDs light up. Then release the button.
4. Position a test bar code symbol approximately 750 mm [30 inches] from the reader. Skew the bar code symbol slightly.
5. The laser(s) should scan continuously during normal operation. (Observe the laser safety warnings.)
6. Observe the LEDs. The LEDs light up when the reader is scanning and decoding the bar code symbol, and indicate the approximate read rate of the scan (see 5.5.1).

5.2 BASIC INSTALLATION PROCEDURES WITH THE MA 900

1. Mechanically install the scanner(s) according to the application drawing for your system.
2. Install the MA 900 according to the application drawing or at a location that provides optimum wiring access to scanner(s), encoder (rotation encoder) and photoelectric sensor.
3. If using more than one scanner, connect the host cable to ETH1 of the designated master scanner. Then connect the ETH2 connection from the master to the ETH1 connection of the first slave, and then the ETH2 connection of the first slave to the ETH1 connection of the next slave and so on.
4. Connect the 25 pin I/O communication cable from the scanner (master only in multihead systems) to the MA 900.
5. Route the supply line from the encoder (rotation encoder) and photoelectric sensor into the MA 900 (see sections 3.11 and 3.10).
6. After the scanner(s), MA 900 and accessories have been carefully wired, switch on the system.
7. When everything is powered up, connect a laptop to ETH2 of the scanner (last slave in a multihead system).
8. Open a browser and enter the default IP address (192.168.3.100, see section 4.1.2). The user interface opens.



NOTE: detailed information on connecting a laptop to the system and using the user interface is available in *Chapter 4*.

9. Log on to the user interface (see section 4.1.2).
10. From the menu tree, select **Modify settings | System info**.

The screenshot shows a web interface with two main sections: 'System Info' and 'Device Information'.

System Info:

- System Description: Induct
- Role: Standalone

Device Information:

Model	Dev	MAC Addr	Software Version	Description	ID
	0	0007BE00EF8A	ARM_release_v0_9_0_0	Master	<input type="button" value="ID"/>

Below the table is an 'Edit...' dropdown menu. At the bottom of the interface are 'Update' and 'Reset' buttons.

11. Select **Standalone** (single head) or **Master** (multihead) from the **Role** drop-down list.
12. If "Master" is selected, the system is poled, and the other scanners are added to the Device Information list.
13. From **Modify settings | Global settings | Operating mode**, select a mode, trigger source and encoder setting.

Operating Mode

Operating Mode Selection Packtrack

Trigger Source

Start Input Number Trigger (Input 1)

Start Input Active Level Active Closed

Transmission Edge Trailing

Mode Settings

Distance from PS Line to Tx Line 2499 mm

PS Line 0 mm

Minimum Package Length 51 mm

Minimum Distance Error Behaviour Compose

Minimum Distance Between Packages 30 mm

Window Dimension 15 mm

Encoder Settings

Physical Encoder Enable

Encoder Step (hundredths of millimeter) 64

Beam Shutter Settings

Beam Shutter Disabled

Update Reset

14. Adjust the bar code settings in **Modify settings | Global settings | Barcode settings table** according to the needs of your system.

Barcode Settings

Idx	Symbology	Minimum Length	Maximum Length
<input checked="" type="radio"/> 1	Code 128	8	40
<input type="radio"/> 2	Code 39	4	40
<input type="radio"/> 3	Disabled		
<input type="radio"/> 4	Disabled		
<input type="radio"/> 5	Disabled		

Barcode 1

Enable

Code Symbology Code 128

Minimum Label Length 8

Maximum Label Length 40

Match String Rule Match

Pattern Match String (max. 200 chars)

Code Label Local No Read String (max. 48 chars) ????

Options

Decoding Safety 1

Bar Count Variable

Match Direction Rule Disable

Update Reset

15. In **Modify settings | Global settings | Barcode configuration**, select single, multiple or logical combination of labels, based on your application.

Barcode Configuration

Code Combination Single Label

No Read Message Local No Read(s) Mes

Multi Filters

Update Reset

16. Move through the menu tree to configure the **Serial ports**, **Ethernet** and **Messaging** settings based on your application requirements.
17. In **Global settings | Messaging | Message format**, change the **Message Tx selection** to **After reading phase OFF**.

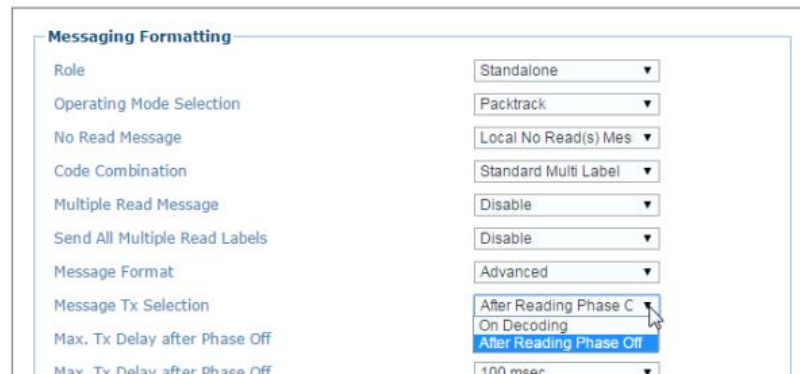

18. Run the **PackTrack** calibration procedure (see section 5.6).
19. When the scanner(s) has/have been configured and calibrated, back up the system configuration using **Utilities | Backup or Restore**. It is recommended to save the system parameters to the backup module on the MA 900 and to a file on your computer.

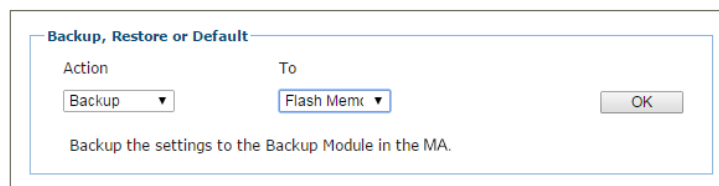

20. Select **Save** from the **Action** drop-down list, and select **Flash memory** from the **To** drop-down list.
21. Click **OK**. The following message will be displayed.



22. Next, select **Backup** from the **Action** drop-down list, and select **File** from the **To** drop-down list.
23. Click **OK** to download the configuration text file (param.txt) to your computer.

5.3 BASIC INSTALLATION PROCEDURES WITH MSC 900 CONTROLLER

1. Mechanically install the scanners according to the application drawing for your system.
2. Install the MSC 900 according to the application drawing or at a location that provides optimum wiring access to scanner(s), encoder (rotation encoder) and photoelectric sensor.
3. Connect the host cable to the HOST connection of the MSC 900 (see figure below). Next, connect the ETH2 connection from the MSC 900 to the ETH1 connection of the first slave, and then the ETH2 connection of the first slave to the ETH1 connection of the next slave and so on. If wiring the scanners in a complete ring configuration, connect ETH2 of the last slave in the series to ETH1 of the MSC 900.

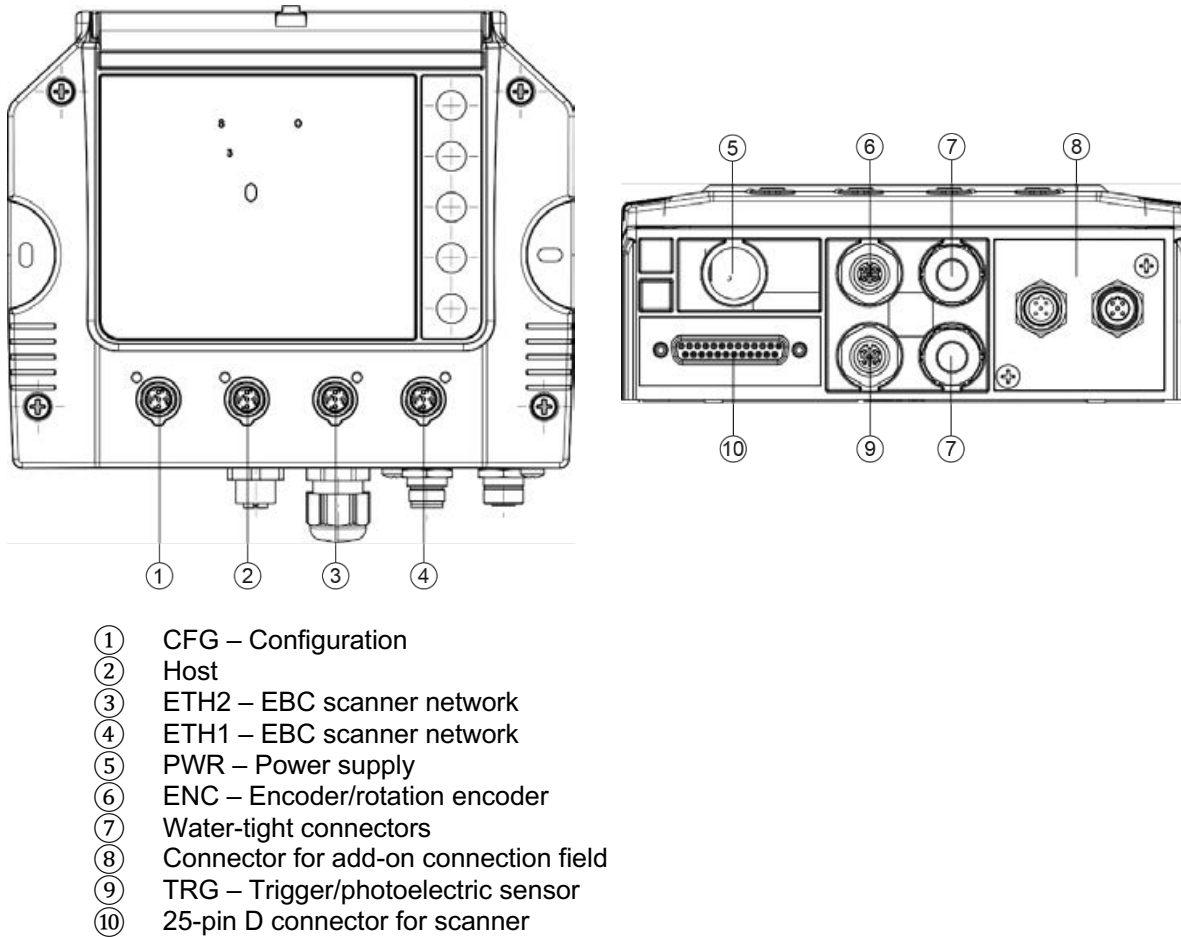

Figure 31 - Connection field of MSC 900 standard model

4. Connect the encoder (rotation encoder) and photoelectric sensor (trigger) to the bottom of the MSC 900 controller (see figure above).
5. Connect the (unpowered) power supplies to the scanners and MSC 900.
6. After the scanner(s), MSC 900 and accessories have been carefully wired, switch on the system.

7. When everything is powered up, connect a laptop to the CFG port on the front of the MSC 900. In a open (non-ring) system, the laptop can be connected to ETH2 of the scanner.
8. Open a browser and enter the default IP address (192.168.3.100, see *section 4.1.2*). The user interface opens.



NOTE: detailed information on connecting a laptop to the system and using the user interface is available in *Chapter 4*.

9. Log on to the user interface (see *section 4.1.2*).
10. From the menu tree, select **Modify settings | System info**.

The screenshot shows the 'System Info' and 'Device Information' sections of a web interface. The 'System Info' section includes fields for 'System Description' (set to 'TunnelWithController'), 'Role' (set to 'Master'), and 'Enable Automatic Slave Replace' (unchecked). Below this are 'Master Tools' buttons for 'Discover Scanners' and 'Distribute Software'. The 'Device Information' section contains a table with columns for Model, Dev, MAC Addr, Software Version, and Description. It lists four devices: a Controller (Dev 0) and three Scanners (Dev 1, 2, 3). Each scanner entry has an 'ID' button. At the bottom of the interface are 'Update' and 'Reset' buttons.

Model	Dev	MAC Addr	Software Version	Description	
	0	0007BE0099C0	ARM_release_v0_9_0_0	Controller	
	1	0007BE00CE59	ARM_release_v0_8_8_0	Scanner3	ID
	2	0007BE00DACD	ARM_release_v0_8_8_0	Scanner2	ID
	3	0007BE00EF89	ARM_release_v0_8_8_0	Scanner1	ID

11. If "Master" is selected, the system is poled, and the other scanners are added to the Device Information list. The MSC 900 controller always serves as the master when used.
12. From **Modify settings | Global settings | Operating mode**, select a mode, trigger source and encoder setting.

Operating Mode

Operating Mode Selection Packtrack ▼

Trigger Source

Start Input Number Trigger (Input 1) ▼

Start Input Active Level Active Closed ▼

Transmission Edge Trailing ▼

Mode Settings

Distance from PS Line to Tx Line 2499 mm

PS Line 0 mm

Minimum Package Length 51 mm

Minimum Distance Error Behaviour Compose ▼

Minimum Distance Between Packages 30 mm

Window Dimension 15 mm

Encoder Settings

Physical Encoder Enable ▼

Encoder Step (hundredths of millimeter) 64

Beam Shutter Settings

Beam Shutter Disabled ▼

13. Adjust the bar code settings in **Modify settings | Global settings | Barcode settings table** according to the needs of your system.

Barcode Settings

Idx	Symbology	Minimum Length	Maximum Length
1	Code 128	8	40
2	Code 39	4	40
3	Disabled		
4	Disabled		
5	Disabled		

Barcode 1

Enable

Code Symbology Code 128 ▼

Minimum Label Length 8

Maximum Label Length 40

Match String Rule Match ▼

Pattern Match String (max. 200 chars)

Code Label Local No Read String (max. 48 chars)

Options

Decoding Safety 1

Bar Count Variable ▼

Match Direction Rule Disable ▼

14. In **Modify settings | Global settings | Barcode configuration**, select single, multiple or logical combination of labels, based on your application.

Barcode Configuration

Code Combination Single Label ▼

No Read Message Local No Read(s) Mes ▼

Multi Filters

- 15. Move through the menu tree to configure the **Serial ports**, **Ethernet** and **Messaging** settings based on your application requirements.
- 16. In **Global settings | Messaging | Message format**, change the **Message Tx selection** to **After reading phase OFF**.

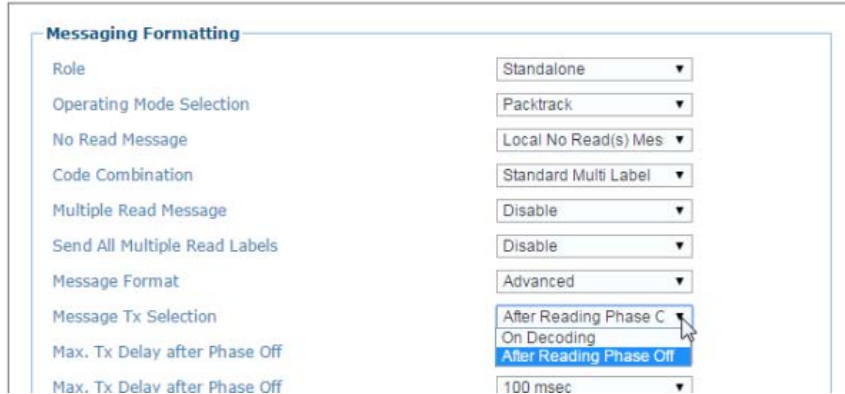

- 17. Run the **PackTrack** calibration procedure (see section 5.6).
- 18. When the scanner(s) has/have been configured and calibrated, back up the system configuration using **Utilities | Backup or Restore**. It is recommended to save the system parameters to the *flash memory* on the MSC 900 and to a file on your computer.

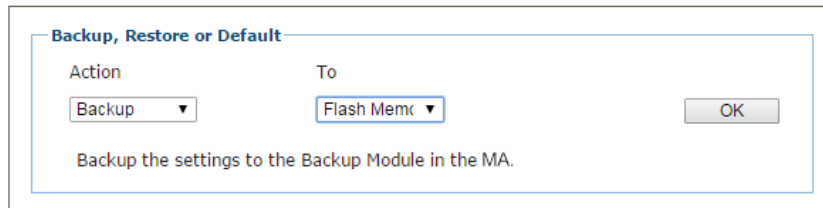

- 19. Select **Save** from the **Action** drop-down list, and select **Flash memory** from the **To** drop-down list.
- 20. Click **OK**. The following message will be displayed.



- 21. Next, select **Backup** from the **Action** drop-down list, and select **File** from the **To** drop-down list.
- 22. Click **OK** to download the configuration text file (param.txt) to your computer.

5.4 LED INDICATORS

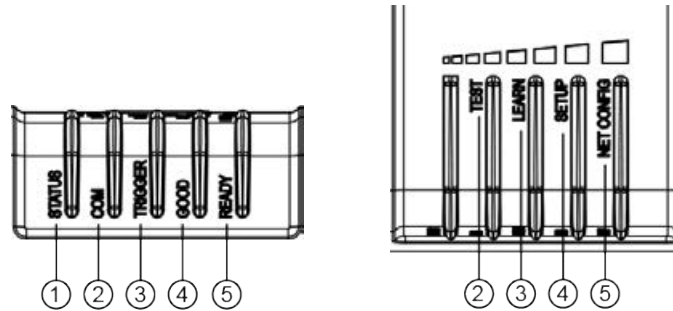

The BCL 900i bar code scanners have several LED rows on the top cover plate and front panel.



- ① STATUS
- ② COM/TEST
- ③ TRIGGER/LEARN
- ④ GOOD/SETUP
- ⑤ READY/NETCONFIG

Figure 32: LED indicators (front and top views)

The indicators have the following meaning:

LED	Description
STATUS	Flashes RED in the case of a NO READ
COM / TEST	Flashes YELLOW to indicate data transmission from main serial port.  NOTE: when the operating mode is set to PackTrack (see section 4.5.1), these LEDs are inactive on slave scanners.
TRIGGER/LEARN	Flashes YELLOW to indicate an active external presence sensor.  NOTE: when the operating mode is set to PackTrack (see section 4.5.1), these LEDs are inactive on slave scanners.
GOOD / SETUP	Flashes GREEN to indicate that a bar code was successfully read.
READY / NETCONFIG	Continuous GREEN indicates that the device is ready to operate.

For alternate functions, see 5.5.1 Human-machine interface below.

5.5 CONTROL PANEL BUTTONS

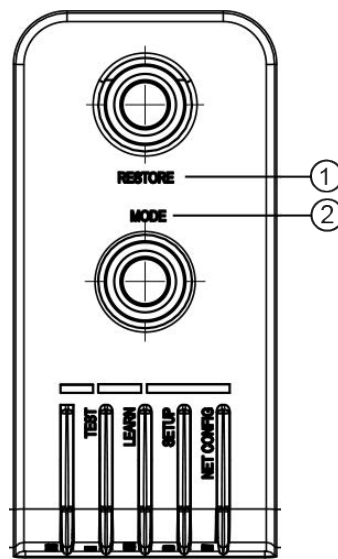

- ① RESTORE
- ② MODE

Figure 33: Control panel buttons

5.5.1 Human-machine interface

The intuitive human-machine interface is designed to improve ease of installation and maintenance.

Status information is clearly presented by means of the five colored LEDs, while the single pushbutton gives immediate access to the following relevant functions:

- **TEST** with bar graph visualization to check static reading performance
- **LEARN** to self-detect and auto-configure to enable unknown codes to be read
- **SETUP** (not used at this time)
- **NETCONFIG** to locate and configure slave scanners in a array (tunnel)

HMI functions (Mode)

Quick access to the following functions is provided by an easy procedure using the MODE button:

1. Press the button (the Status LED gives visual feedback).
2. Hold down the button until the respective function LED lights up (**TEST**, **LEARN**, **SETUP** or **NETCONFIG**).
3. Release the button to enter the respective function.

If the button is pressed and held, the LEDs are activated in the following sequence:

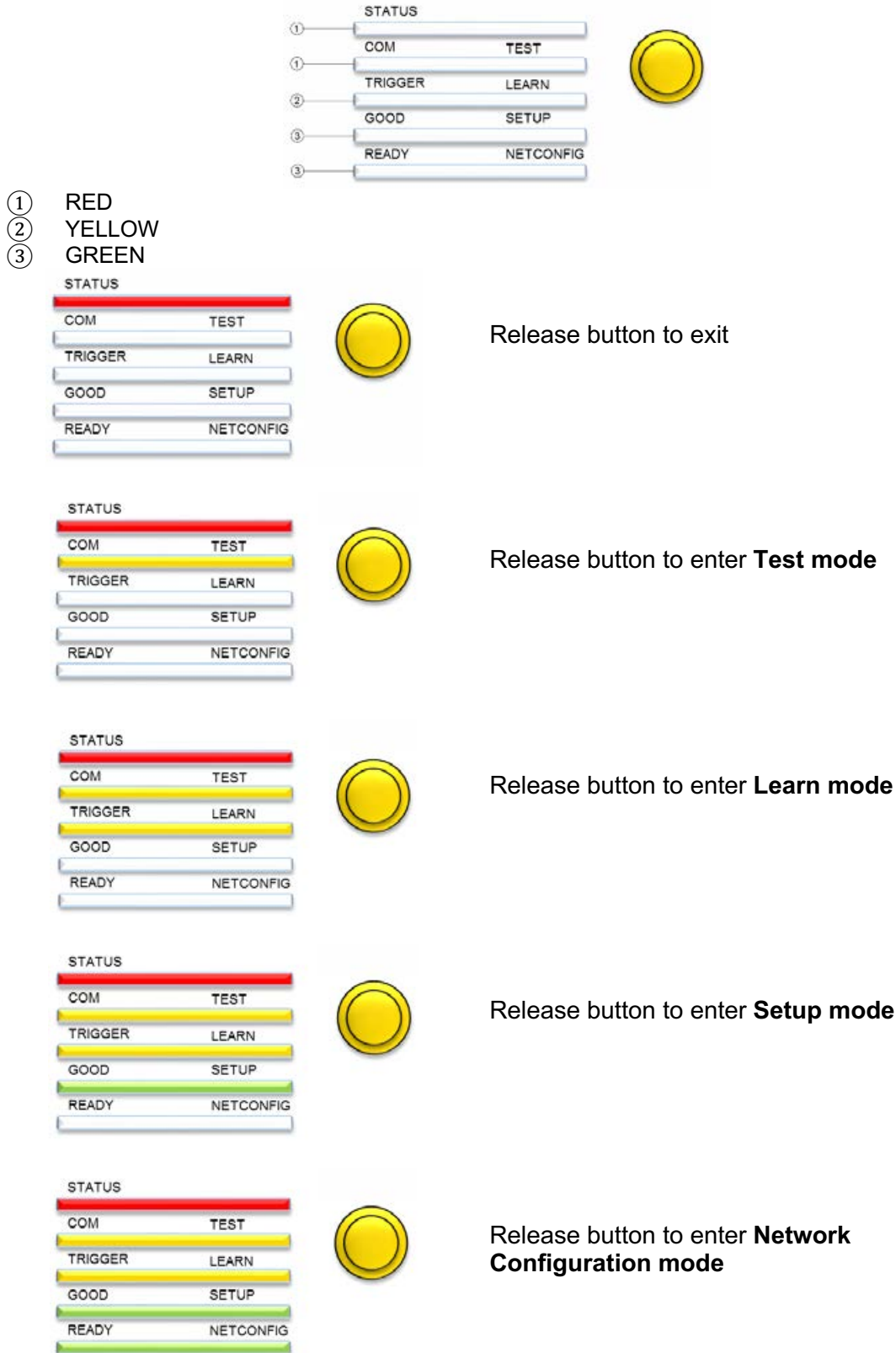

Figure 34: HMI LEDs for operating modes

Test mode

When this mode is entered, the five LEDs are activated. When the scanner starts reading the bar codes, the LEDs indicate the reading rate percentage. In case of a NO READ, only the Status LED flashes.

The LEDs indicate the read rate percentage as follows:

	STATUS	
≥ 20%	COM	TEST
≥ 40%	TRIGGER	LEARN
≥ 60%	GOOD	SETUP
≥ 75%	READY	NETCONFIG
≥ 95%		

To exit **Test mode**, press the **MODE** button once.



NOTE: by default, Test mode ends automatically after two minutes.

Learn mode

When this mode is entered, the **LEARN** LED flashes and the scanner starts a procedure to automatically detect and recognize bar codes which are presented to it.

Place a bar code in the scan line so that the **LEARN** LED lights up continuously for a short time as the processing and decoding parameters are successfully saved.

If calibration cannot be achieved after a timeout of about 3 (three) minutes, the scanner will exit Learn mode without saving the parameters.

Setup

Not used at this time.

Netconfig mode

When this operating mode is entered from a master scanner in a multi-scanner array (tunnel), the system detects and identifies slave scanners in the array. The slave scanners (and the master) will then be available in the user interface (see *chapter 4*).

Press the MODE button again to exit the mode.

5.5.2 Restore button and other functions

Function	Description
Scanner replacement	Hold down the RESTORE button until all LEDs light up. After all LEDs go out, the READY LED comes back on. Parameters stored in the MA 900 are now being used in the scanner.
Software recovery mode	Hold down the MODE button while the scanner is powered up.
Reset scanner to factory defaults	Hold down the MODE and RESTORE buttons while the scanner is powered up. If resetting to the defaults settings was successful, all LEDs will light up three times.

5.6 PACKTRACK™

PackTrack is a patented operating mode for omni-directional reading stations used to read and correctly assign codes read on different packs when placed in the scanner reading field at the same time.

In the following example, the codes of two or more consecutive packages are found at the same time in the scanner reading field. As a result, in the sequence of the two packages, the code of the second package is read first, immediately before the code of the preceding package. A system without **PackTrack** would assign the code of the second package to the first package and vice versa, thus causing a gross error in sortation.

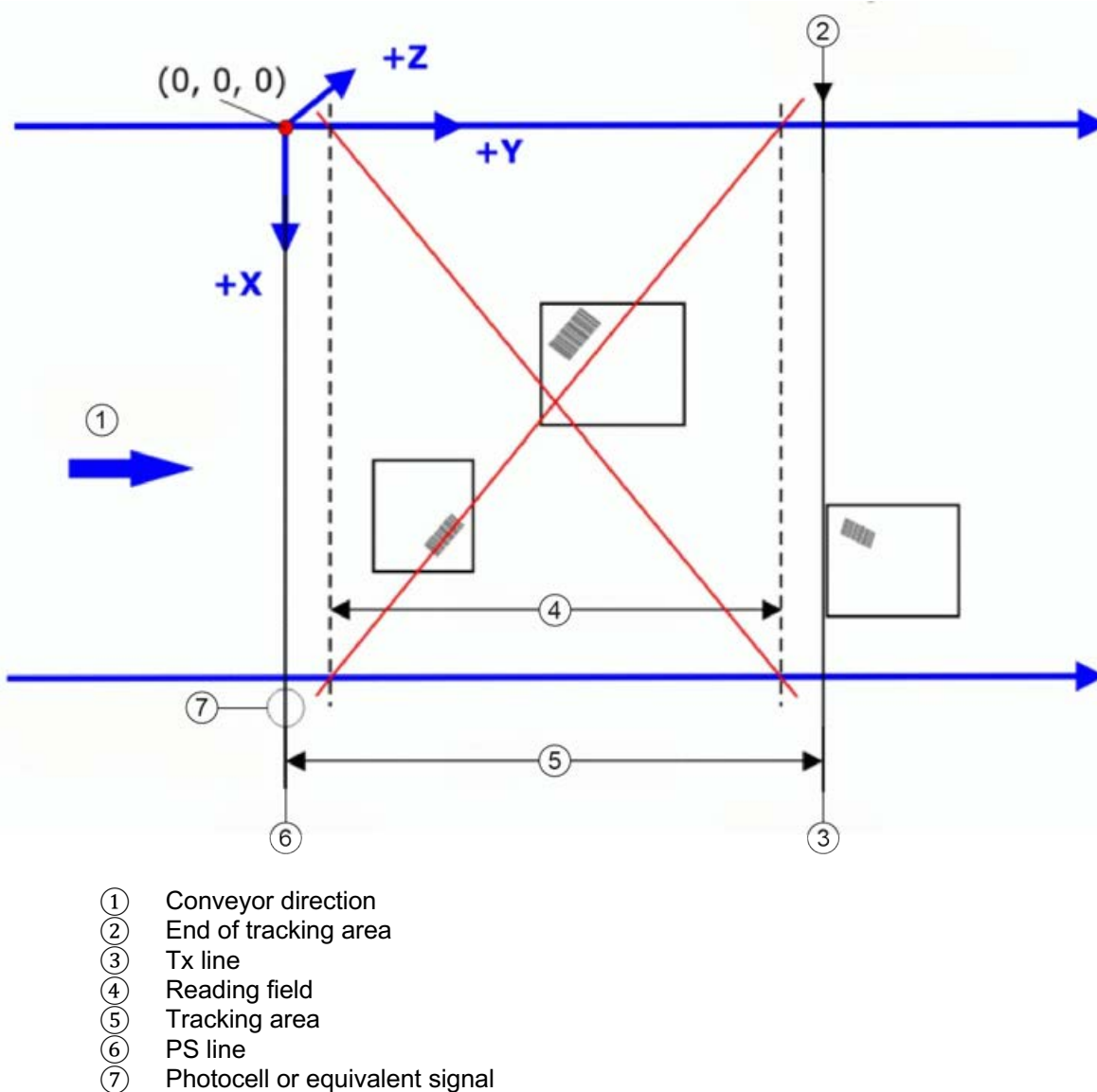
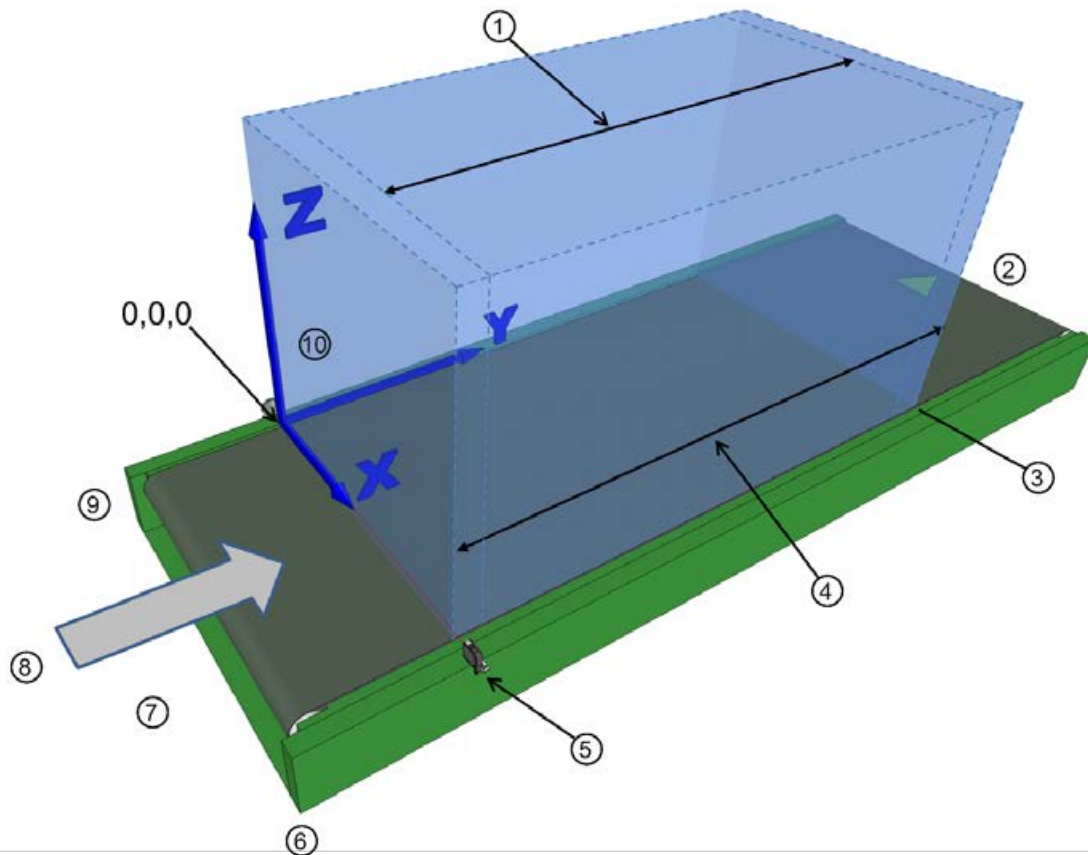

Figure 35: Tracking problem

PackTrack uses a right-handed reference system where the **X** axis coincides with the photoelectric sensor line, the **Y** axis coincides with the conveyor direction, and the **Z** axis is oriented upwards from the conveyor (see figure below). The arrows point in the positive direction. The coordinate point of origin (0,0,0) is on the left edge of the conveyor as illustrated.



- ① Reading field
- ② Downstream
- ③ Transmit (Tx) point, end of tracking
- ④ Tracking area
- ⑤ Photoelectric sensor or equivalent trigger signal (X-coordinate)
- ⑥ Right side
- ⑦ Upstream
- ⑧ Conveyor direction
- ⑨ Left Side
- ⑩ XYZ coordinate orientation

Figure 36: Tracking area

This coordinate system is absolute for the reading station, i.e. valid for all the scanners irrespective of their position or orientation with respect to the conveying belt. For this reason, after the **PackTrack** configuration (and calibration) has been correctly performed, when a bar code is under the beam in order to be read by the scanners, its position is defined by the coordinates of its central point, regardless of which scanner is reading it.

Step-by-step procedures for calibrating top-mounted (see 5.6.2) and side-mounted (see 5.6.3) bar code scanners are described below.

5.6.1 Using the PackTrack wizard

Before you begin calibration:

1. In **Modify settings | Global settings | Barcode settings**, select and configure a system bar code.
2. In **Modify settings | Global settings | Barcode configuration**, create a **global no read message** you can easily recognize, such as **NO READ**.
3. In **Modify settings | Global settings | Operating mode**, select **PackTrack** as the **operating mode**. Make sure that the mode settings and encoder settings match your system parameters.
4. Navigate to **Diagnostics | Read test**.
5. Place a system bar code in the scan line of the bar code scanner.
6. Click **Start test**. The scanner should successfully read the bar code. If it does not read it successfully or registers a low read rate, check the system specifications for mounting distance and the bar code specifications. Then make adjustments as necessary and repeat the test. If the scanner continues to have problems reading the bar code, contact Leuze electronic (www.leuze.com).

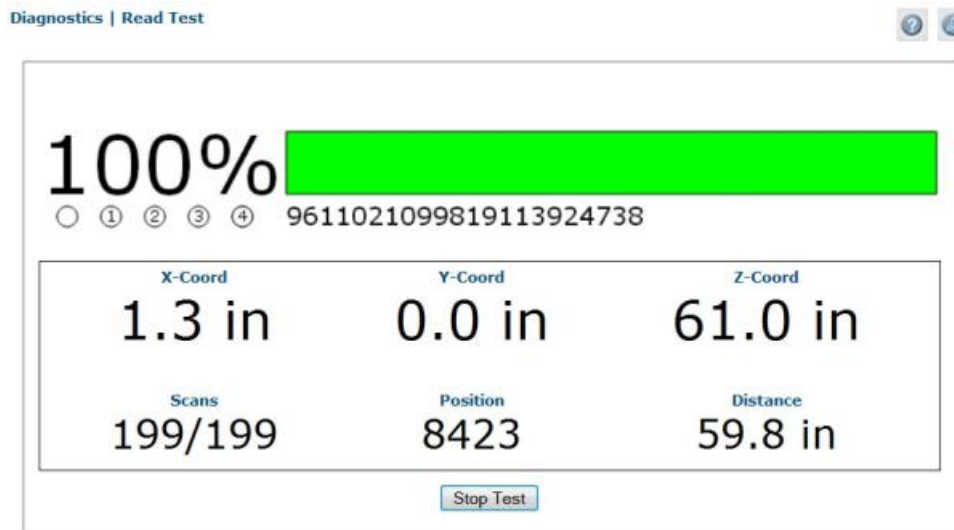

7. Click **Stop test**.

To launch the PackTrack wizard:

1. In the menu tree under **Modify settings**, navigate to **Device settings | Device name (if applicable) | Mounting**. The **Mounting** window opens.
2. Select **PackTrack calibration** from the "Mounting Specifications" drop-down list.

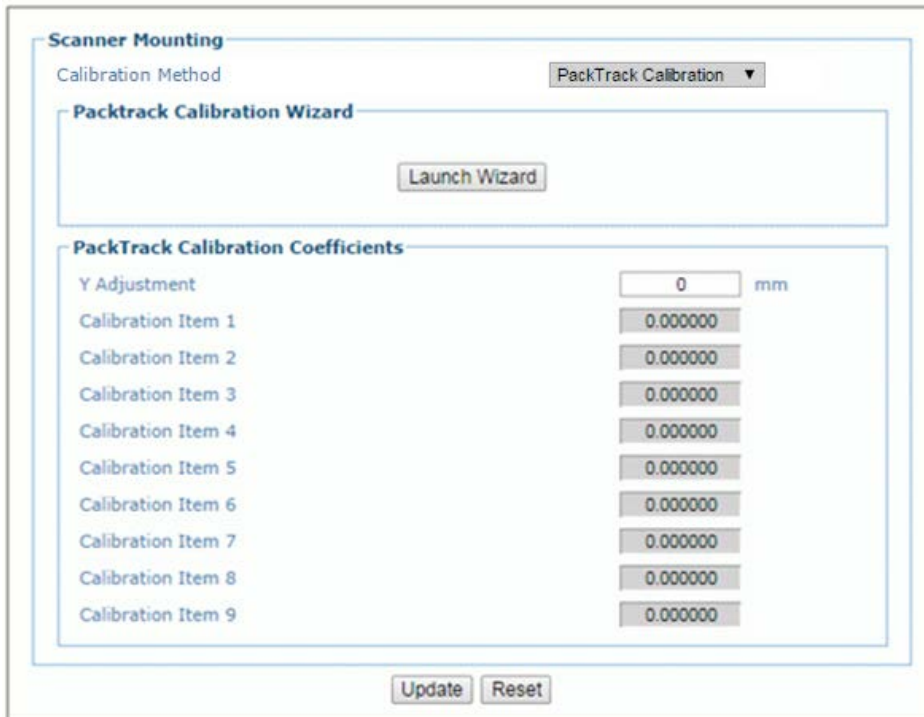

3. Click **Launch wizard**. The **PackTrack calibration wizard** window opens.

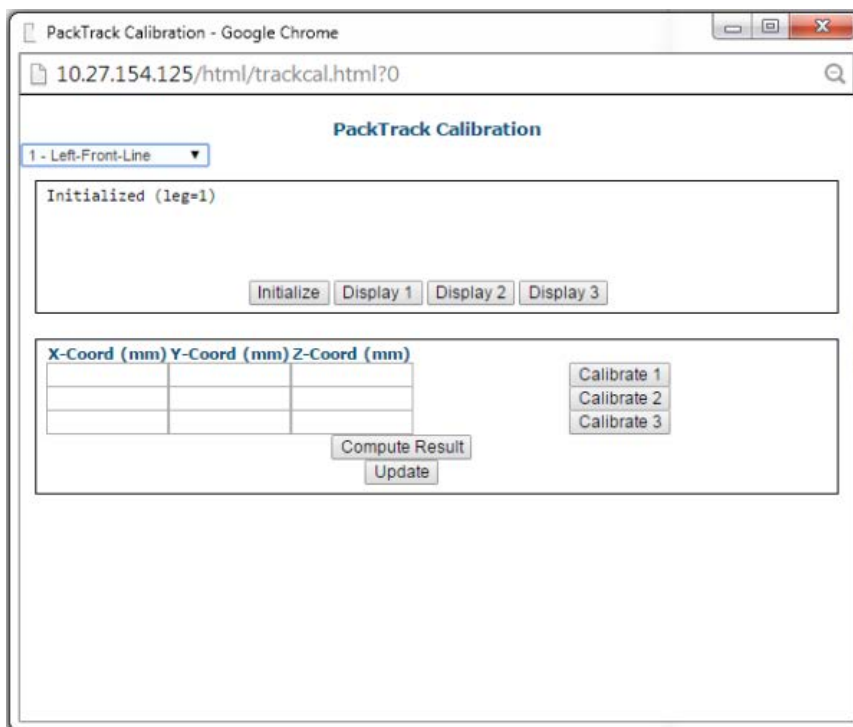

The **PackTrack calibration wizard** asks you to physically measure and enter bar code coordinates for the extremes of your bar code scanning system. You must now measure and enter XYZ coordinates for bar codes at three different locations along the bar code scanner laser line(s) for each system scanner, as shown for **top-mounted** and **side-mounted** scanners in the illustrations below.

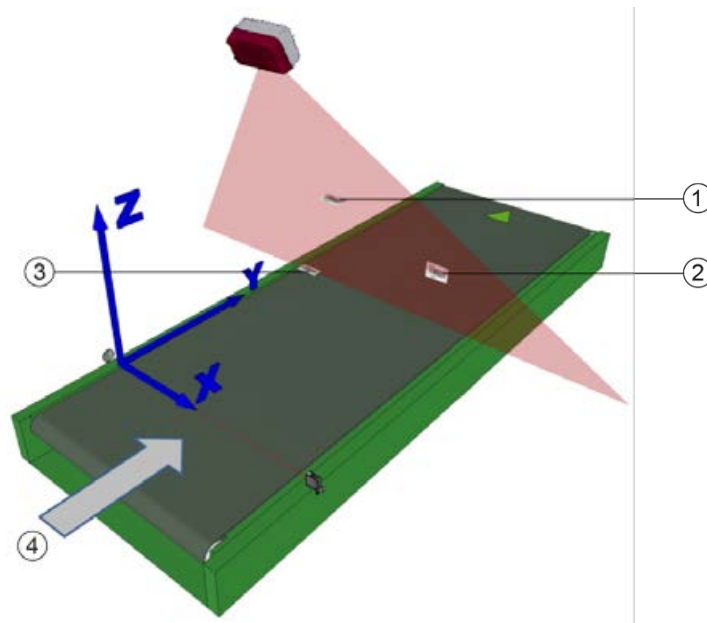

- ① Centered above conveyor bed at top of tallest box
- ② At mid-height on right edge of conveyor bed
- ③ Left side, lying on conveyor bed
- ④ Conveyor direction

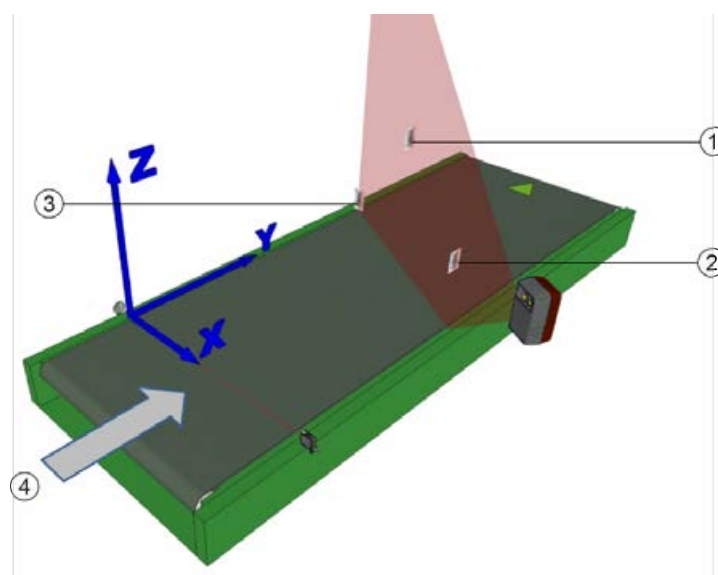

- ① Centered above conveyor bed at top of tallest box
- ② At mid-height on right edge of conveyor bed
- ③ Left side close to conveyor bed
- ④ Conveyor direction

Figure 37: Bar code positions for top-mounted and side-mounted bar code scanners



NOTE: a bar code test chart is included in the box with each scanner, and a code from the chart can be used to perform the test. You can also use a standard barcode from your specific application; however, test the code to ensure that the scanner reads it 100% by using the **Diagnosis | Read test** option in the user interface (see 4.7.2).

5.6.2 Calibration of top-mounted bar code scanners using PackTrack



NOTE: it is not possible to show every possible installation angle and scanner mounting position in this manual. Use the following steps as a general guide to calibrating each system scanner using bar codes at three positions. You will need to make adjustments to the label/box position based on your situation. It is, however, important to note the fixed XYZ coordinates of the conveying belt.

With the conveyor stopped, measure and enter the XYZ coordinate data of the bar code for each scanner as follows:

1. Make sure that the intended scanner (in a multi-head system) has been selected from the drop-down lists at the top of the wizard window.
2. Start by laying a system bar code on the conveying belt bed in the laser line as close to the left edge (X=0 edge) as possible. See illustration below.

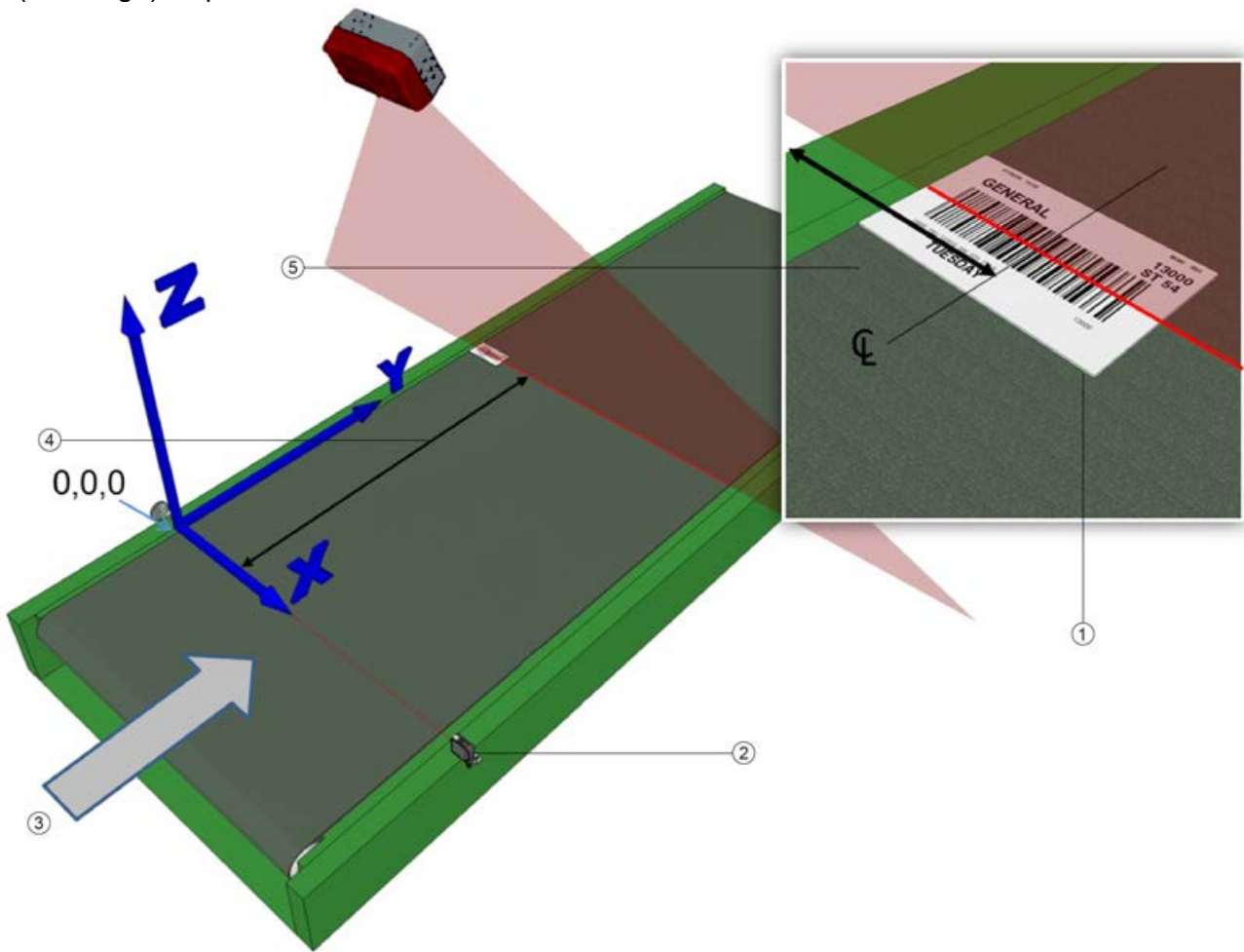

- ① Z-distance – conveyor bed surface to code (Z = 0 with code laid on conveyor)
- ② Trigger
- ③ Conveyor direction
- ④ Y-distance – trigger to scan line
- ⑤ X-distance – conveyor bed edge to center of bar code

Figure 38: Positioning of first top-read bar code

3. Measure the distance for **X** from the edge of the conveyor bed to the center of the bar code, and enter this distance in the first field under **X-Coord (mm)** in the **PackTrack Calibration Wizard**.

Your measurements will likely differ from those shown below.

X-Coord (mm)	Y-Coord (mm)	Z-Coord (mm)
100		

4. Measure the distance for **Y** from the trigger (PS line) to the bar code scanner's laser line on the bar code, and enter this distance in the first field under **Y-Coord (mm)**.

Your measurements will likely differ from those shown below.

X-Coord (mm)	Y-Coord (mm)	Z-Coord (mm)
100	70	

5. Measure the distance for **Z** from the conveyor bed to the bar code, and enter that distance in the first field under **Z-Coord (mm)**. Since the bar code is lying on the conveyor bed, the value should be "0".

Your measurements will likely differ from those shown below.

X-Coord (mm)	Y-Coord (mm)	Z-Coord (mm)
100	70	0

6. Click **Calibrate 1**. The PackTrack data is displayed for the first code.

Code 1 - X/Y/Z: 100.000000 / 70.000000 / 0.000000
 (Leg 1) Dist/Angle: 1003.550000 / 0.118065

X-Coord (mm)	Y-Coord (mm)	Z-Coord (mm)
100	70	0

7. Next, place a bar code overhanging the top corner of the tallest box specified for your scanning system as shown in the illustration below. Center one edge of the box on the conveying belt and align the other edge with the laser line as shown.

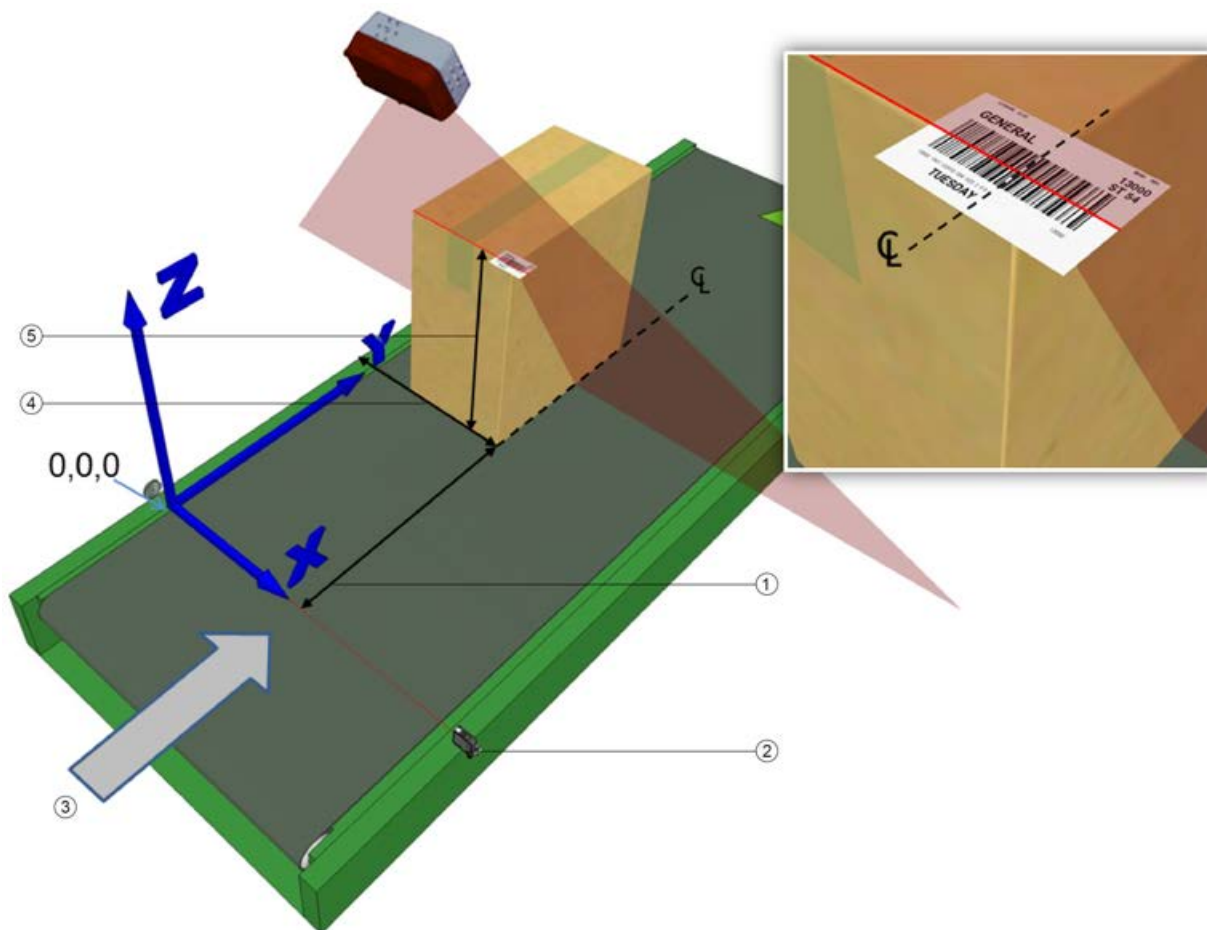

- ① Y-distance – trigger to scan line (box edge)
- ② Trigger
- ③ Conveyor direction
- ④ X-distance – conveyor bed edge to center of bar code
- ⑤ Z-distance – conveyor bed surface to scan line (top of box)

Figure 39: Positioning of second top-read bar code

8. Measure the distance for **X** from the left edge of the conveyor bed to the center of the bar code (centered side edge of box), and enter this distance in the first field under **X-Coord (mm)**.

Your measurements will likely differ from those shown below.

X-Coord (mm)	Y-Coord (mm)	Z-Coord (mm)
100	70	0
280		

- Measure the distance for **Y** from the trigger (PS line) to the bar code scanner's laser line on the bar code (back edge of box), and enter this distance in the first field under **Y-Coord (mm)**.

Your measurements will likely differ from those shown below.

X-Coord (mm)	Y-Coord (mm)	Z-Coord (mm)
100	70	0
280	165	

- Measure the distance for **Z** from the conveyor bed to the bar code (top of box), and enter this distance in the first field under **Z-Coord (mm)**.

Your measurements will likely differ from those shown below.

X-Coord (mm)	Y-Coord (mm)	Z-Coord (mm)
100	70	0
280	165	160

- Click **Calibrate 2**. The PackTrack data is displayed for the second code.

```
Code 2 - X/Y/Z:      280.000000 / 165.000000 / 160.000000
(Leg 1)  Dist/Angle: 816.225000 / -0.073688
```

Initialize Display 1 Display 2 Display 3

X-Coord (mm)	Y-Coord (mm)	Z-Coord (mm)
100	70	0
280	165	160

Compute Result
Update

Calibrate 1
Calibrate 2
Calibrate 3

12. Finally, place a system bar code on the back right edge of a box, about halfway up the scanner field of view as shown in the illustration below.

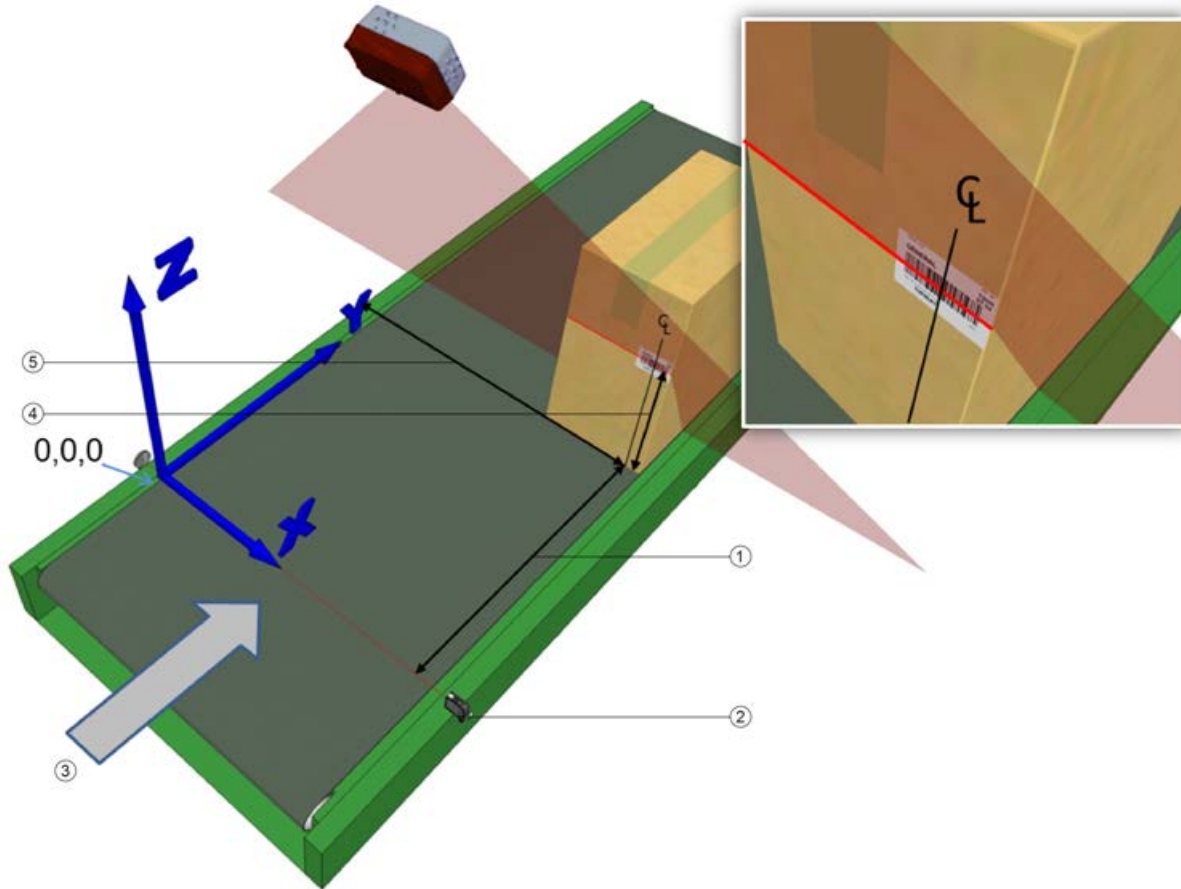

- ① Y-distance – trigger to scan line (box edge)
- ② Trigger
- ③ Conveyor direction
- ④ Z-distance – conveyor bed surface to scan line
- ⑤ X-distance – conveyor bed edge to center of code

Figure 40: Positioning of third top-read bar code

13. Measure the distance for **X** from the left edge of the conveyor bed to the center of the bar code, and enter this distance in the first field under **X-Coord (mm)**.

Your measurements will likely differ from those shown below.

X-Coord (mm)	Y-Coord (mm)	Z-Coord (mm)
100	70	0
280		

14. Measure the distance for **Y** from the trigger (PS line) to the bar code scanner's laser line on the bar code (back edge of box), and enter this distance in the first field under **Y-Coord (mm)**.

Your measurements will likely differ from those shown below.

X-Coord (mm)	Y-Coord (mm)	Z-Coord (mm)
100	70	0
280	165	

15. Measure the distance for **Z** from the conveyor bed to the laser line intersecting the bar code, and enter this distance in the first field under **Z-Coord (mm)**.

Your measurements will likely differ from those shown below.

X-Coord (mm)	Y-Coord (mm)	Z-Coord (mm)
100	70	0
280	165	160

16. Click **Calibrate 3**. The PackTrack data is displayed for the third code.

Code 3 - X/Y/Z: 400.000000 / 120.000000 / 80.000000
 (Leg 1) Dist/Angle: 930.525000 / -0.181289

X-Coord (mm)	Y-Coord (mm)	Z-Coord (mm)
100	70	0
280	165	160
400	120	80

17. Click Compute results. The results are displayed at the top of the **PackTrack calibration** window.

Result: -1.064197 0.053396 172.585510
 -0.037263 -0.484000 556.741272
 -0.042378 -0.835064 837.203674

X-Coord (mm)	Y-Coord (mm)	Z-Coord (mm)	
<input type="text" value="100"/>	<input type="text" value="70"/>	<input type="text" value="0"/>	<input type="button" value="Calibrate 1"/>
<input type="text" value="280"/>	<input type="text" value="165"/>	<input type="text" value="160"/>	<input type="button" value="Calibrate 2"/>
<input type="text" value="400"/>	<input type="text" value="120"/>	<input type="text" value="80"/>	<input type="button" value="Calibrate 3"/>
<input type="button" value="Compute Result"/>			
<input type="button" value="Update"/>			

18. Click **Update**. "Update successful" should be displayed in the **PackTrack calibration** window.

19. Close the **PackTrack Calibration Wizard** window. The **PackTrack calibration coefficients** have been entered in the Scanner Mounting window.

Scanner Mounting

Calibration Method PackTrack Calibration ▼

Packtrack Calibration Wizard

PackTrack Calibration Coefficients

Y Adjustment	<input type="text" value="0"/> mm
Calibration Item 1	<input type="text" value="-1.064197"/>
Calibration Item 2	<input type="text" value="0.053396"/>
Calibration Item 3	<input type="text" value="172.585510"/>
Calibration Item 4	<input type="text" value="-0.037263"/>
Calibration Item 5	<input type="text" value="-0.484000"/>
Calibration Item 6	<input type="text" value="556.741272"/>
Calibration Item 7	<input type="text" value="-0.042378"/>
Calibration Item 8	<input type="text" value="-0.835064"/>
Calibration Item 9	<input type="text" value="837.203674"/>

20. When you have finished making changes, click **Update** to save or click **Reset** to revert to the previously saved values.

21. See **Checking PackTrack calibration** below.

5.6.3 Calibration of side-mounted bar code scanners using PackTrack



NOTE: it is not possible to show every possible installation angle and scanner mounting position in this manual. Use the following steps as a general guide to calibrating each system scanner using bar codes at three positions. You will need to make adjustments to the label/box position based on your situation. It is, however, important to note the fixed XYZ coordinates of the conveying belt.

With the conveyor stopped, measure and enter the XYZ coordinate data of the bar code for each scanner as follows:

1. Start by placing a system bar code projecting halfway over the lower left edge of a box, and then place the box along the edge of the conveyor belt as shown in the illustration below.

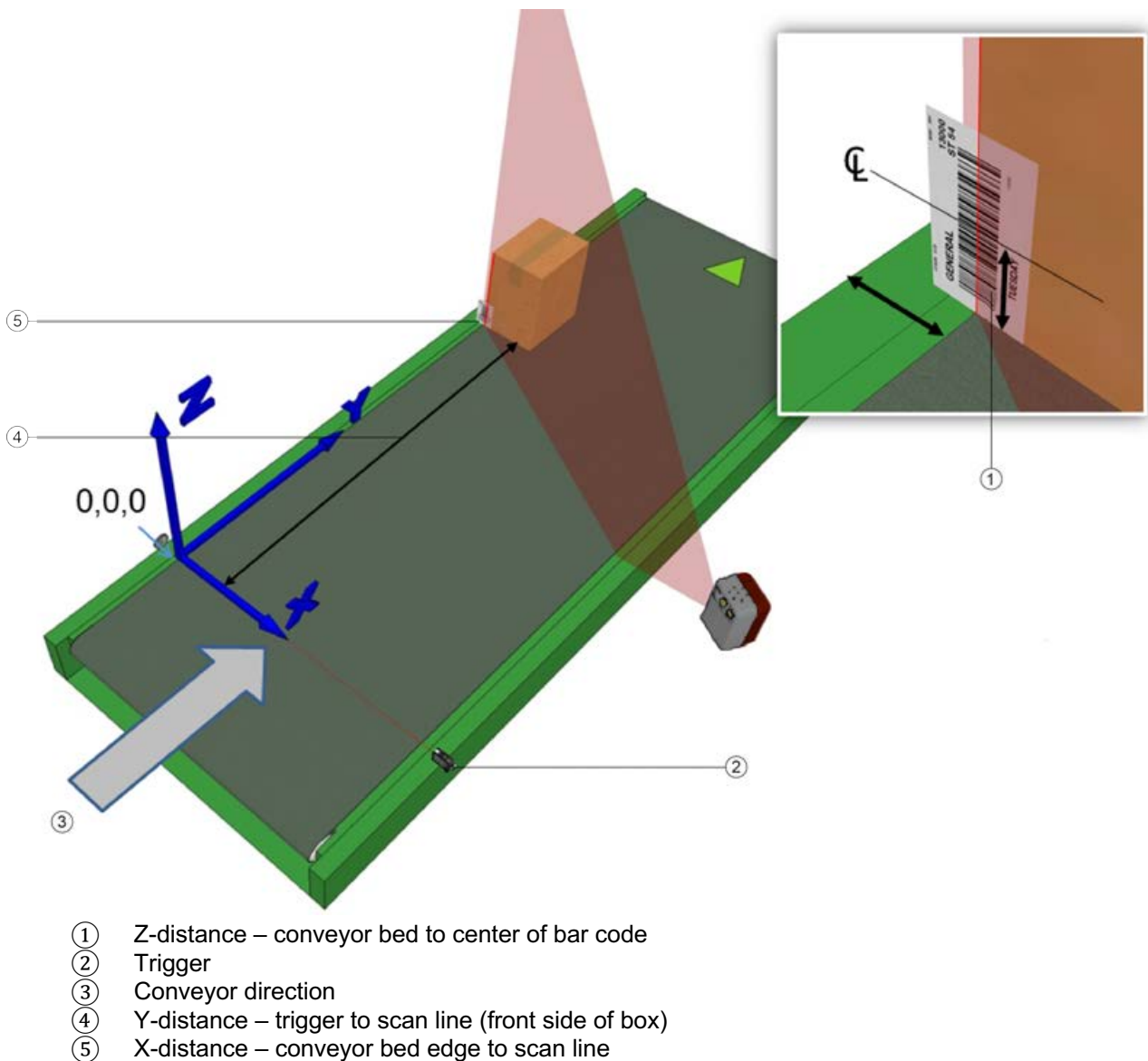

- ① Z-distance – conveyor bed to center of bar code
- ② Trigger
- ③ Conveyor direction
- ④ Y-distance – trigger to scan line (front side of box)
- ⑤ X-distance – conveyor bed edge to scan line

Figure 41: Positioning of first side-read bar code

- Measure the distance for **X** from the edge of the conveyor bed to the laser line centered on the bar code, and enter this distance in the first field under **X-Coord (mm)** in the **PackTrack calibration wizard**.

Your measurements will likely differ from those shown below.

X-Coord (mm)	Y-Coord (mm)	Z-Coord (mm)
100		

- Measure the distance for **Y** from the trigger (PS line) to the back edge of the box, and enter this distance in the first field under **Y-Coord (mm)**.

Your measurements will likely differ from those shown below.

X-Coord (mm)	Y-Coord (mm)	Z-Coord (mm)
100	70	

- Measure the distance for **Z** from the conveyor bed to the center of the bar code, and enter this distance in the first field under **Z-Coord (mm)**.

Your measurements will likely differ from those shown below.

X-Coord (mm)	Y-Coord (mm)	Z-Coord (mm)
100	70	50

- Click **Calibrate 1**. The PackTrack data is displayed for the first code.

```
Code 1 - X/Y/Z: 100.000000 / 70.000000 50.000000
(Leg 1) Dist/Angle: 1003.550000 / 0.118065
```

Initialize Display 1 Display 2 Display 3

X-Coord (mm)	Y-Coord (mm)	Z-Coord (mm)
100	70	50

Calibrate 1
Calibrate 2
Calibrate 3

Compute Result
Update

- Next, place a bar code overhanging the top corner of the tallest box specified for your scanning system as shown in the illustration below. Center the right edge of the box on the conveyor aligning the right back corner with the laser line as shown.

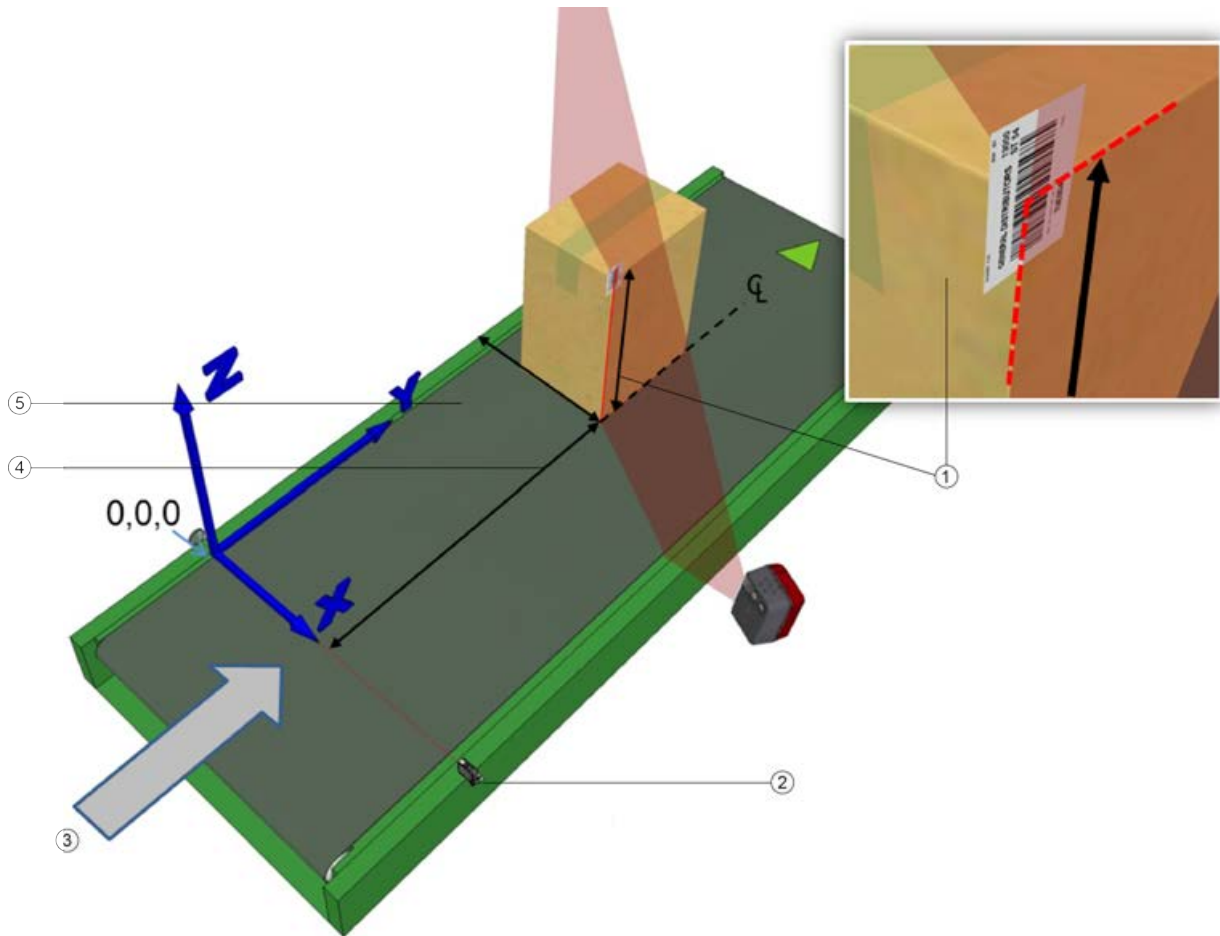

- ① Z-distance – conveyor bed to center of code (top of box)
- ② Trigger
- ③ Conveyor direction
- ④ Y-distance – trigger to scan line (front side of box)
- ⑤ X-distance – conveyor bed edge to scan line

Figure 42: Positioning of second side-read bar code

- Measure the distance for **X** from the left edge of the conveyor bed to the center of the bar code (right edge of box), and enter this distance in the first field under **X-Coord (mm)**.

Your measurements will likely differ from those shown below.

X-Coord (mm)	Y-Coord (mm)	Z-Coord (mm)
100	70	50
280		

- Measure the distance for **Y** from the trigger (PS line) to the back edge of the box, and enter this distance in the first field under **Y-Coord (mm)**.

Your measurements will likely differ from those shown below.

X-Coord (mm)	Y-Coord (mm)	Z-Coord (mm)
100	70	50
280	165	

- Measure the distance for **Z** from the conveyor bed to the center of the bar code (top of box), and enter this distance in the first field under **Z-Coord (mm)**.

Your measurements will likely differ from those shown below.

X-Coord (mm)	Y-Coord (mm)	Z-Coord (mm)
100	70	50
280	165	160

- Click **Calibrate 2**. The PackTrack data is displayed for the second code.

Code 2 - X/Y/Z: 280.000000 / 165.000000 / 160.000000
 (Leg 1) Dist/Angle: 816.225000 / -0.073688

X-Coord (mm)	Y-Coord (mm)	Z-Coord (mm)
100	70	50
280	165	160

11. Finally, place a system bar code on the back right edge of a box, about halfway up the scanner field of view as shown in the illustration below.

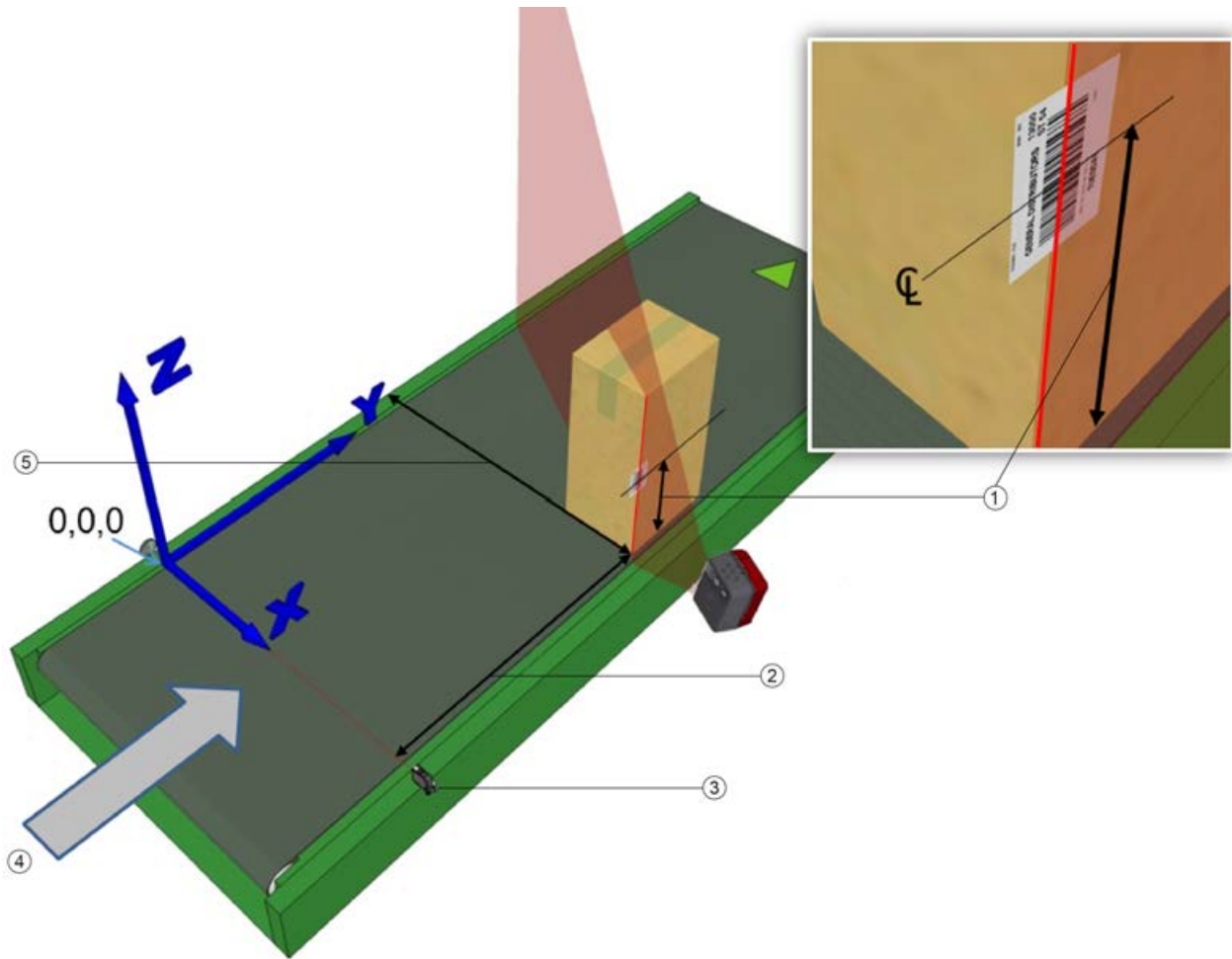

- ① Z-distance – conveyor bed to center of code (top of box)
- ② Y-distance – trigger to scan line (front side of box)
- ③ Trigger
- ④ Conveyor direction
- ⑤ X-distance – conveyor bed edge to scan line

Figure 43: Positioning of third side-read bar code

12. Measure the distance for **X** from the left edge of the conveyor bed to the center of the bar code, and enter this distance in the first field under **X-Coord (mm)**.

Your measurements will likely differ from those shown below.

X-Coord (mm)	Y-Coord (mm)	Z-Coord (mm)
100	70	50
280	165	160
400		

13. Measure the distance for **Y** from the trigger (PS line) to the bar code scanner's laser line on the bar code (back edge of box), and enter this distance in the first field under **Y-Coord (mm)**.

Your measurements will likely differ from those shown below.

X-Coord (mm)	Y-Coord (mm)	Z-Coord (mm)
100	70	50
280	165	160
400	120	

14. Measure the distance for **Z** from the conveyor bed to the laser line intersecting the bar code, and enter this distance in the first field under **Z-Coord (mm)**.

Your measurements will likely differ from those shown below.

X-Coord (mm)	Y-Coord (mm)	Z-Coord (mm)
100	70	50
280	165	160
400	120	80

15. Click **Calibrate 3**. The PackTrack data is displayed for the third code.

Code 3 - X/Y/Z: 400.000000 / 120.000000 / 80.000000
 (Leg 1) Dist/Angle: 930.525000 / -0.181289

X-Coord (mm)	Y-Coord (mm)	Z-Coord (mm)
100	70	50
280	165	160
400	120	80

16. Click Compute results. The results are displayed at the top of the **PackTrack calibration** window.

Result: -1.064197 0.053396 172.585510
 -0.037263 -0.484000 556.741272
 -0.042378 -0.835064 837.203674

X-Coord (mm)	Y-Coord (mm)	Z-Coord (mm)	
<input type="text" value="100"/>	<input type="text" value="70"/>	<input type="text" value="50"/>	<input type="button" value="Calibrate 1"/>
<input type="text" value="280"/>	<input type="text" value="165"/>	<input type="text" value="160"/>	<input type="button" value="Calibrate 2"/>
<input type="text" value="400"/>	<input type="text" value="120"/>	<input type="text" value="80"/>	<input type="button" value="Calibrate 3"/>
<input type="button" value="Compute Result"/>			
<input type="button" value="Update"/>			

17. Click **Update**. "Update successful" should be displayed in the **PackTrack calibration** window.

18. Close the PackTrack Calibration Wizard window. The **PackTrack calibration coefficients** have been entered in the Scanner Mounting window.

Scanner Mounting

Calibration Method PackTrack Calibration ▼

Packtrack Calibration Wizard

PackTrack Calibration Coefficients

Y Adjustment	<input type="text" value="0"/> mm
Calibration Item 1	<input type="text" value="-1.064197"/>
Calibration Item 2	<input type="text" value="0.053396"/>
Calibration Item 3	<input type="text" value="172.585510"/>
Calibration Item 4	<input type="text" value="-0.037263"/>
Calibration Item 5	<input type="text" value="-0.484000"/>
Calibration Item 6	<input type="text" value="556.741272"/>
Calibration Item 7	<input type="text" value="-0.042378"/>
Calibration Item 8	<input type="text" value="-0.835064"/>
Calibration Item 9	<input type="text" value="837.203674"/>

19. When you have finished making changes, click **Update** to save or click **Reset** to revert to the previously saved values.

20. See **Checking PackTrack calibration** below.

5.6.4 Calibration of bottom-mounted bar code scanners using PackTrack

When using the PackTrack Wizard to calibrate a bottom read scanner, three bar code positions are needed for accurate calibration. For the left and right sides of the conveyor, place a bar code label face-down, overhanging the corner of a typical box for your application, as shown below. Place another bar code label on the bottom of a box and place the code along the laser beam in the center of the conveyor bed, as shown in the illustration below.

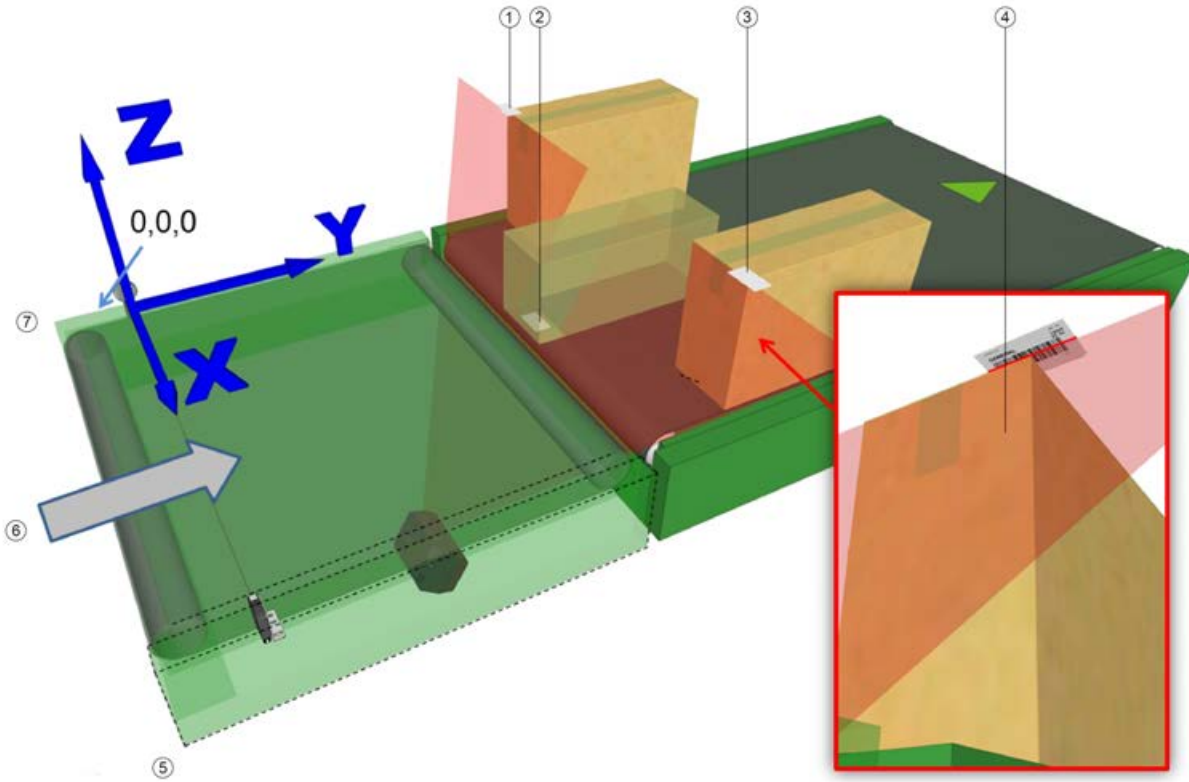

- ① Left side, label face-down overhanging top of box
- ② Centered on conveyor bed on bottom of box
- ③ Right side, label face-down overhanging top of box
- ④ Viewed from below
- ⑤ Right side
- ⑥ Conveyor direction
- ⑦ Left Side

As with the top and side-read examples in this section, enter the X, Y and Z coordinates for each code in the PackTrack Wizard.

5.6.5 Checking PackTrack calibration

1. In the menu tree, navigate to **Diagnostics/Read test**. The **Read test** window opens.

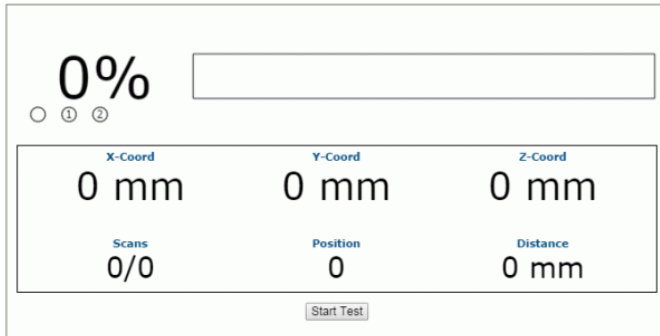

2. Place a bar code anywhere in the scanner's laser beam other than where you placed the labels for calibration.
3. Click **Start test**. The system runs a test to identify the location of the bar code within the reading field and displays the results in the Read test window.

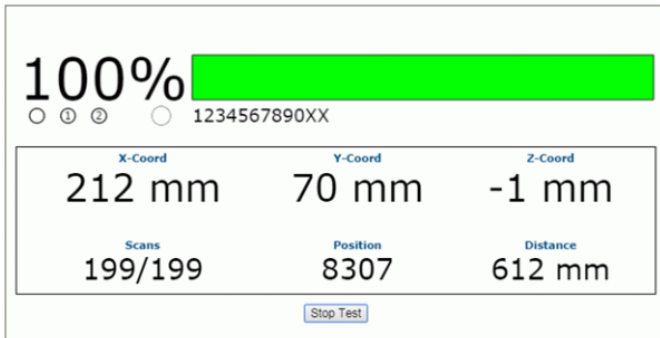

4. Physically measure the X (from left edge), Y (from PS) and Z (code height) coordinates of your test bar code, and compare your measured results with the **Read test** results. Your measured results and those displayed should be close (within a few millimeters) but do not need to be exactly the same.

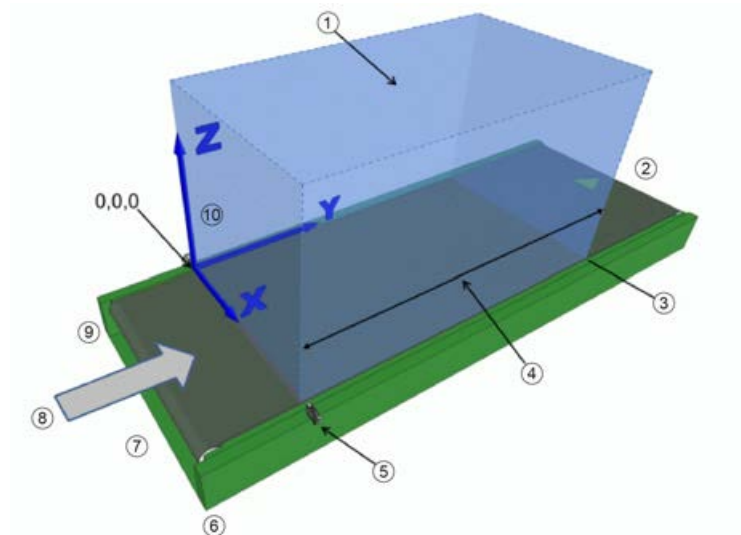

- ① Reading field
- ② Downstream
- ③ Transmit (Tx) point, end of tracking
- ④ Tracking area
- ⑤ Photoelectric sensor or equivalent trigger signal (X-coordinate)
- ⑥ Right side
- ⑦ Upstream
- ⑧ Conveyor direction
- ⑨ Left Side
- ⑩ XYZ coordinate orientation

Figure 44: Tracking area

5. Next, in the menu tree, navigate to **Diagnostics/Monitor**.
6. Switch on the conveyor and run a box with a readable bar code past the bar code scanner.
7. Check the **Monitor** to make sure that the bar code on the box is being read. If NO READ is displayed (i.e. the bar code on the box is not being read), double check your physical measurements you entered in the **PackTrack calibration wizard** and enter them again.

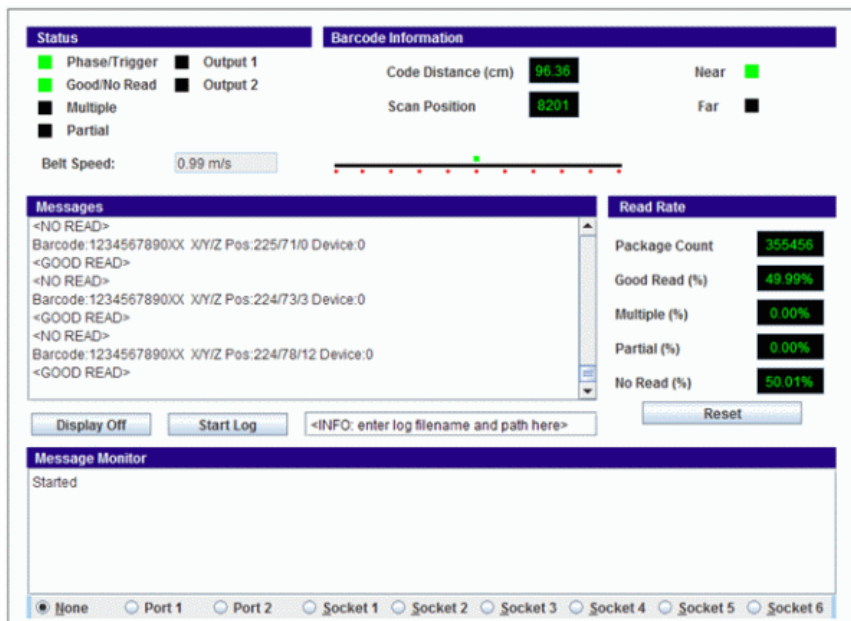

5.7 REPLACING AN INSTALLED BCL 900I

If, for any reason, a scanner fails, it can be replaced quickly with a spare unit with parameters recovered from the flash memory or a saved parameter file.



NOTE: this procedure assumes that system parameters have been properly saved as described in sections 4.8.1, 5.2 and 5.3.



NOTE: if you are not sure whether the replacement scanner has been defaulted to the factory settings, it is a good idea to default the device before installing it in a system. To do this proceed as follows:

1. Connect a power cable to the replacement scanner and switch on the operating voltage.
2. Press and hold down the yellow **MODE** and **RESTORE** buttons simultaneously on the device until the LEDs flash three times.
3. Release the buttons. The device is now reset to the factory default.

5.7.1 Replacing a stand-alone scanner using RESTORE

A stand-alone scanner (a single scanner not connected to an array/tunnel) can be replaced by pressing the **RESTORE** button located near the LEDs on the side of the housing.

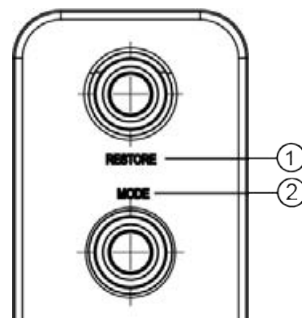

- ① RESTORE
- ② MODE

Figure 45: Restore button

To replace the scanner using **RESTORE**:

1. Switch off the existing scanner and remove the power supply and I/O cables.
2. Label the cables connected to ETH1 and/or ETH2 so you can easily identify where they were connected, then remove the cables.
3. Detach the existing scanner from its mounting bracket, leaving the bracket attached to the mounting structure.
4. Attach the replacement scanner to the mounting bracket.
5. Reconnect the power supply, I/O, ETH1 and/or ETH2 cables.
6. Switch on the system.
7. Once the scanner has booted up and the **READY** LED lights up green continuously, press and hold the **RESTORE** button until all of the LEDs light up, indicating that the parameters are being restored from the backup module of the MA 900.
8. Release the **RESTORE** button. The green **READY** LED should light up again.

5.7.2 Replacing a slave scanner in an array/tunnel automatically

The user interface provides an option for automatically replacing a slave scanner in a tunnel when the system is configured. To enable this option in the user interface, select **Modify setting/System info** from the user interface menu tree. The System info window opens.

The screenshot shows the 'System Info' window. The 'System Description' field contains 'Test Tunnel'. The 'Role' dropdown is set to 'Master'. The 'Enable Automatic Slave Replace' checkbox is checked and highlighted with a red rectangle. Below this are 'Master Tools' buttons for 'Discover Scanners' and 'Distribute Software'. The 'Device Information' section contains a table with the following data:

Model	Dev	MAC Addr	Software Version	Description	ID
	0	000E13040103	ARM_release_v0_9_0_0	Top-X	ID
	1	0007BE00F238	ARM_release_v0_9_0_0	Left-Front-Line	ID

At the bottom of the window are 'Update' and 'Reset' buttons.

1. Select the **Enable automatic slave replacement** check box, click **Update** and save the system parameters as *described in sections 4.8.1, 5.2 and 5.3*.
2. If the **Enable automatic slave replacement** check box has been selected and saved in the system parameters, use the following procedure to replace a slave scanner:
3. Switch off the array.
4. Remove the power supply and I/O cables from the scanner being replaced.
5. Label the cables connected to ETH1 and/or ETH2 so you can easily identify where they were connected, then remove the cables.
6. Detach the existing scanner from its mounting bracket, leaving the bracket attached to the mounting structure.
7. Attach the replacement scanner to the mounting bracket.
8. Reconnect the power supply, I/O, ETH1 and/or ETH2 cables.
9. Switch on the array. The system will automatically find the system parameters and download them to the replacement scanner.

5.7.3 Replacing a slave scanner in an array/tunnel using RESTORE

If the **Enable automatic slave replacement** check box has NOT been selected and saved in the system parameters, use the following procedure to replace a slave scanner:

1. Switch off the array.
2. Remove the power supply and I/O cables from the scanner being replaced.
3. Label the cables connected to ETH1 and/or ETH2 so you can easily identify where they were connected, then remove the cables.
4. Detach the existing scanner from its mounting bracket, leaving the bracket attached to the mounting structure.
5. Attach the replacement scanner to the mounting bracket.
6. Reconnect the power supply, I/O, ETH1 and/or ETH2 cables.

7. Switch on the array.
8. Once the scanner has booted up and the **READY** LED lights up green continuously, press and hold the **RESTORE** button until all of the LEDs light up, indicating that the parameters are being restored from the backup module of the MA 900 or from the flash memory of the MSC 900.
9. Release the **RESTORE** button.

5.7.4 Replacing a master scanner in an array/tunnel using RESTORE

1. Switch off the array.
2. Remove the power supply and I/O cables from the master scanner being replaced.
3. Label the cables connected to ETH1 and/or ETH2 so you can easily identify where they were connected, then remove the cables.
4. Detach the existing scanner from its mounting bracket, leaving the bracket attached to the mounting structure.
5. Attach the replacement master scanner to the mounting bracket.
6. Reconnect the power supply, I/O, ETH1 and/or ETH2 cables.
7. Switch on the array.
8. Once the scanner has booted up and the **READY** LED lights up green continuously, press and hold the **RESTORE** button until all of the LEDs light up, indicating that the parameters are being restored from the backup module of the MA 900 or from the flash memory of the MSC 900.
9. Release the **RESTORE** button.

5.7.5 Checking operation of the replacement

With the scanner replaced and your PC connected to the system, navigate to **Modify settings/System info** from the user interface menu tree. The System info window opens.

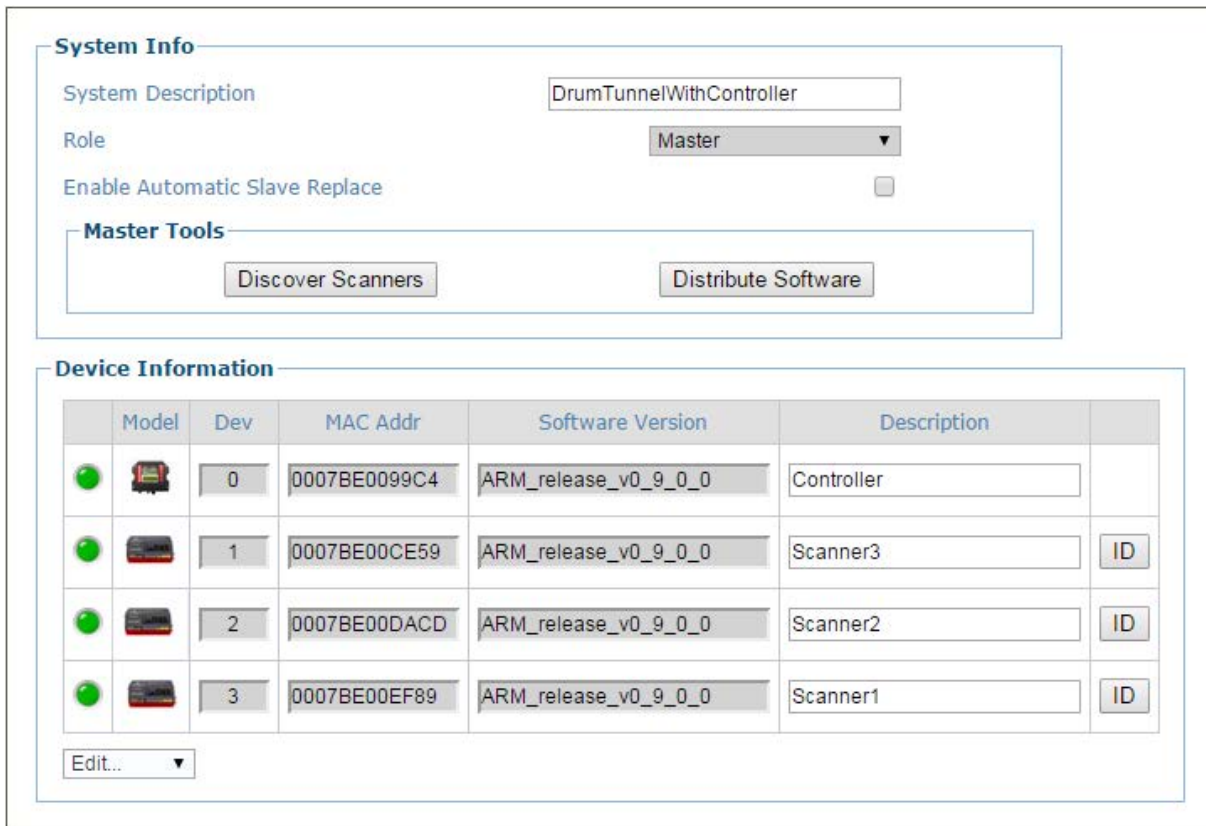

The **Device information** section of the window should now list all of the scanners (and an MSC 900 controller if used), including the scanner you just replaced.

5.8 TYPICAL LAYOUTS

The following typical layouts refer to system hardware configurations, but also require the correct setup of the software configuration parameters.

Other layouts require the use of a specific MSC 900 controller model.

The accessories and cables indicated in the following figures are Leuze electronic products. We recommend their use to ensure correct operation of the system.

5.8.1 Large synchronized network layout

When setting up a large local EBC (Ethernet Based Connectivity) network, an MSC 900 controller should be used. In this case, the MSC 900 unit acts as the system master and is connected to the host through one of its interfaces.

- The MSC 900 can be connected to the host in several different layouts depending on the controller model.

The MSC 900 standard models provide both Ethernet connections (direct or through a hub/switch) and point-to-point connections on the main interface using either RS232 or RS422 full-duplex.

Fieldbus models, additionally provide the model-specific fieldbus standard: PROFIBUS, PROFINET IO, etc.

- All scanners act as slaves and are connected to the MSC 900 through the EBC interface.

External components such as a presence sensor and an encoder are all connected either to the MSC 900 through its M12 connectors or to the MA 900 connection unit (connected to the controller), whereby the signals are routed via the hardwired compression connectors of the MA 900.

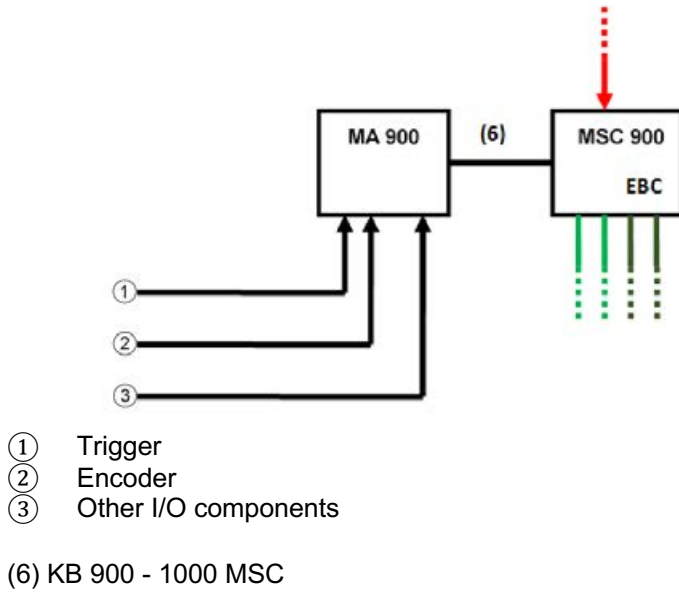

Figure 46 – Large synchronized network with BCL 900i scanners

MSC 900: Basic layout: COM to host

If the host supports COM-type data communication (RS232 or RS422) rather than Ethernet communication, use the MA 900 as an accessory, as shown below.

The remaining part of the layout (scanners, PWR, etc.) remains the same.

As already mentioned, the MA 900 can also be used to wire the trigger and encoder signals (and other I/O signals) as an alternative to the M12 connection.

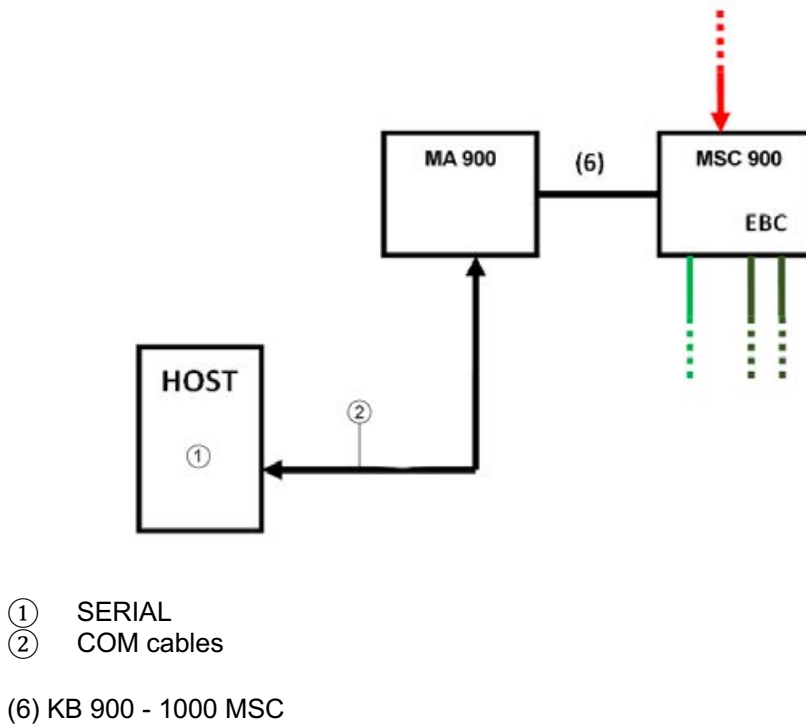

Figure 47 – Large synchronized network with COM to host

5.9 CODE RECONSTRUCTION TECHNOLOGY (CRT)

The traditional way of bar code reading could be referred to as "linear reading". In this case, the laser beam crosses the bar code symbol from its beginning to its end as shown in the following figure:



① Laser beam

Figure48 – Linear reading

In Code Reconstruction Technology mode, it is no longer necessary for the laser beam to cross the label from the start to the end. With just a set of partial scans on the label (obtained using the motion of the label itself), the BCL 900i is able to "reconstruct" the bar code. A typical set of partial scans is shown in the figure below:

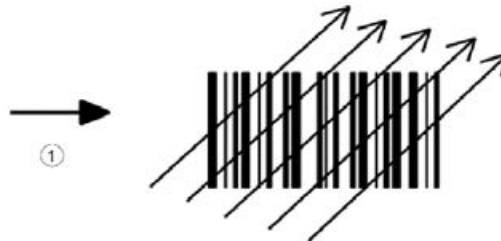

① Code direction

Figure49 – Partial scans

None of the partial scans captures the whole label. The decoder aligns each partial scan correctly and combines them to form the complete code.

The alignment is performed by calculating the time difference from one partial scan to another using a reference code element.

5.9.1 Tilt angle for code reconstruction technology

The most important parameter for code reconstruction technology is the value of the maximum tilt angle (α maximum) under which the code reconstruction process is still possible.

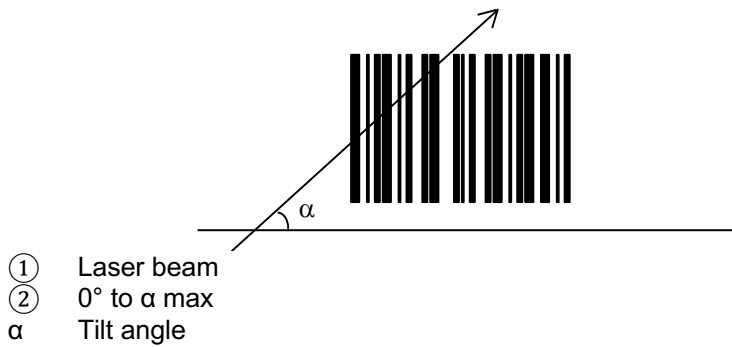

Figure50 – Tilt angle

The decoder will be able to read the label with a tilt angle between $+\alpha$ max and $-\alpha$ max as shown in the following figure:

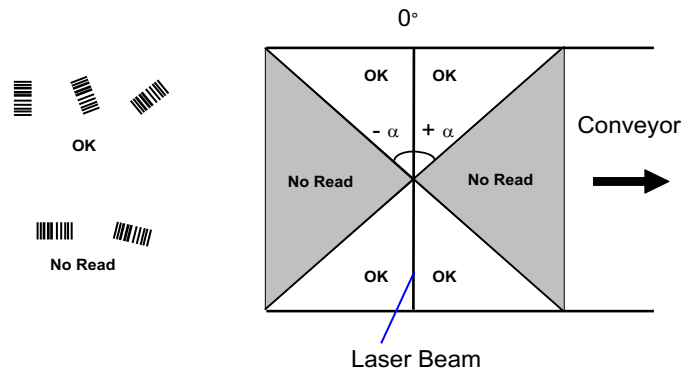

Figure51 – Reading zones with α -maximum

The formulas to calculate α maximum depend on various parameters such as label height, number of scans per second, code motion speed, etc. Minimum label heights at different conveyor speeds are given in the tables in section 5.9.2 for standard α values of 45° and 30° .

5.9.2 Minimum code height for code reconstruction technology

Based on the scanner read rate of 1000 scans/sec., minimum label heights at different conveyor speeds are given in the tables below.

Refer to the reading diagrams in *section 5.10* for further details on the reading functions. These diagrams apply to sample codes with various resolutions at a 25°C ambient temperature based on the conditions listed under each diagram.

- ANSI grade B minimum
- 1000 scans/s

The following tables describe the requirements for standard applications.

		Minimum code height for CRT reading (mm)											
		45°						30°					
		0.5	1	1.5	2	2.5	3	0.5	1	1.5	2	2.5	3
Conveyor speed (m/s)													
2/5 Interleaved Code resolution (mm)	0.25	10	11	13	14	16	17	7	8	9	10	12	13
	0.30	12	13	14	16	17	19	8	9	10	11	12	14
	0.33	12	14	15	17	18	20	8	9	10	12	13	14
	0.38	14	15	16	18	19	21	9	10	11	12	14	15
	0.50	18	18	20	21	23	24	11	12	13	14	15	17
	0.72	24	25	26	27	28	30	15	16	16	18	19	20
	1.00	33	33	34	35	36	37	20	20	21	22	23	24

Ratio 3:1

Table 1

		Minimum code height for CRT reading (mm)											
		45°						30°					
		0.5	1	1.5	2	2.5	3	0.5	1	1.5	2	2.5	3
Conveyor speed (m/s)													
Code 39 Code resolution (mm)	0.25	9	9	11	12	14	15	6	7	8	9	10	11
	0.30	10	11	12	13	15	16	7	7	8	10	11	12
	0.33	11	11	12	14	15	17	7	8	9	10	11	12
	0.38	12	13	13	15	16	18	8	8	9	10	12	13
	0.50	15	16	16	17	18	20	9	10	11	12	13	14
	0.72	20	21	22	22	23	24	13	13	14	14	15	16
	1.00	27	28	29	29	30	31	17	17	18	18	19	20

Ratio 3:1; interdigit = modulus size

Table 2

		Minimum code height for CRT reading (mm)											
		45°						30°					
Conveyor speed (m/s)		0.5	1	1.5	2	2.5	3	0.5	1	1.5	2	2.5	3
Code 128 – GS1-128 Code resolution (mm)	0.25	7	9	10	12	13	15	6	6	8	9	10	11
	0.30	8	9	11	12	14	15	6	7	8	9	10	12
	0.33	9	10	11	13	14	16	6	7	8	9	11	12
	0.38	10	11	12	14	15	17	6	8	9	10	11	12
	0.50	12	13	14	16	17	19	8	9	10	11	12	13
	0.72	16	17	18	19	21	22	10	11	12	13	14	15
	1.00	21	22	23	24	25	26	13	14	15	16	17	18

Table 3

		Minimum code height for CRT reading (mm)											
		45°						30°					
Conveyor speed (m/s)		0.5	1	1.5	2	2.5	3	0.5	1	1.5	2	2.5	3
Codabar Code resolution (mm)	0.25	8	9	10	12	13	15	5	6	8	9	10	11
	0.30	9	9	11	12	14	15	6	7	8	9	10	12
	0.33	9	10	11	13	14	16	6	7	8	9	11	12
	0.38	10	11	12	14	15	17	7	8	9	10	11	12
	0.50	13	13	14	16	17	19	8	9	10	11	12	13
	0.72	17	18	18	19	21	22	11	11	12	13	14	15
	1.00	23	23	24	25	26	26	14	15	15	16	17	18

Ratio 3:1; interdigit = modulus size

Table 4

		Minimum code height for CRT reading (mm)											
		45°						30°					
Conveyor speed (m/s)		0.5	1	1.5	2	2.5	3	0.5	1	1.5	2	2.5	3
EAN 8-13, UPC-A Code resolution (mm)	0.25	7	8	9	11	12	14	5	6	7	8	9	11
	0.30	8	9	10	11	13	14	6	6	7	9	10	11
	0.33	9	10	10	12	13	15	6	7	8	9	10	11
	0.38	10	11	11	12	14	15	6	7	8	9	10	12
	0.50	12	13	14	14	15	17	8	8	9	10	11	12
	0.72	16	17	18	18	19	20	10	11	11	12	13	14
	1.00	21	22	23	24	24	25	13	14	15	15	16	16

Table 5

5.10 READING DIAGRAM

How to identify the scanner model:

The model type is shown on the series name plate.

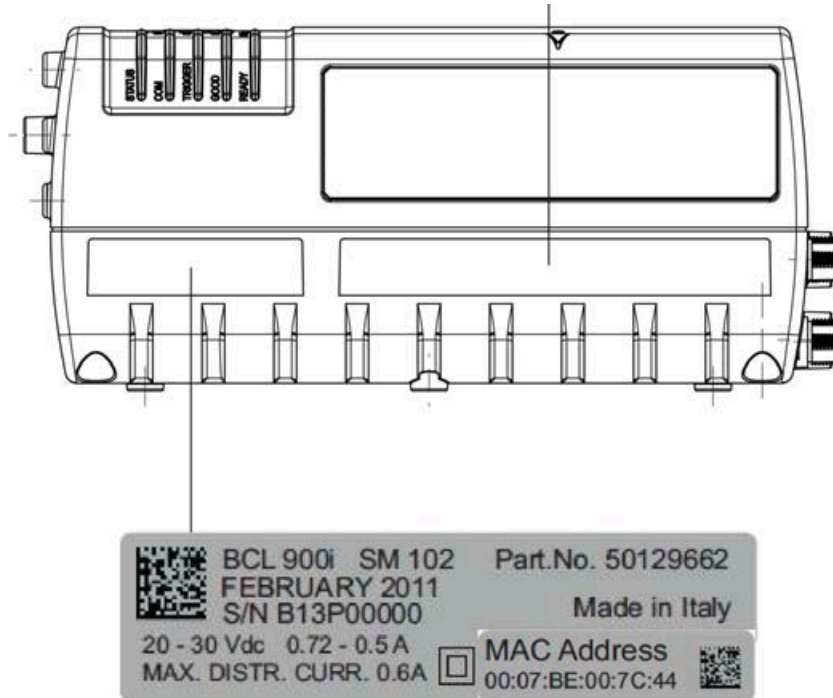
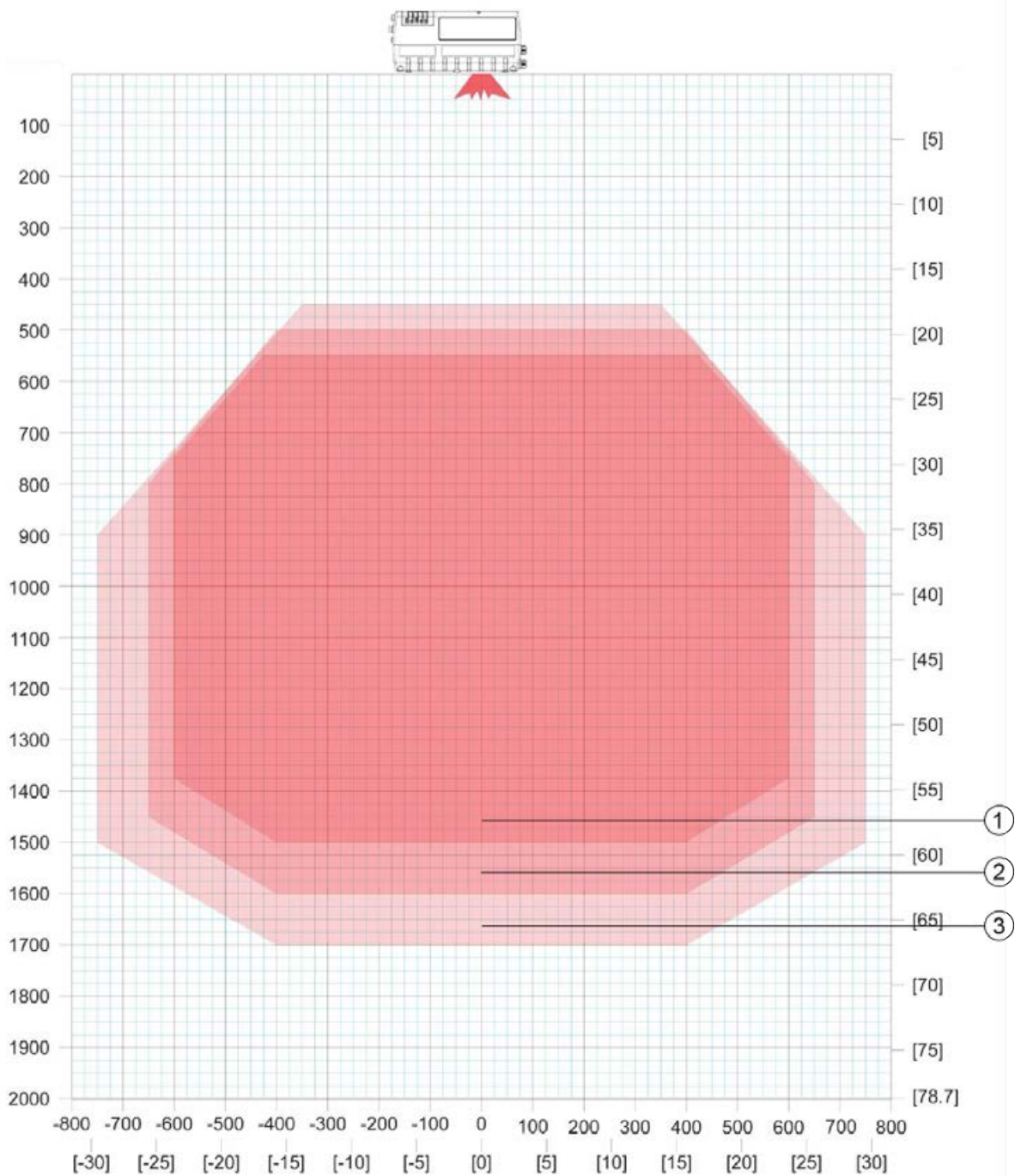

Figure 52 – Identifying scanner model

- BCL 900i SN 102: **High density/resolution**
- BCL 900i SM 102: **Medium density/resolution**

BCL 900i SM 102



1,000 scans per second (standard) over entire DOF
 ANSI contrast grade 84 % or greater
 ANSI "Grade A" print quality

Pitch not greater than +/- 15°
 Skew not greater than +/- 15°
 Tilt not greater than +/- 45°

- ① BCL 900i SM 102 0.33 mm/13 mil
- ② BCL 900i SM 102 0.38 mm/15 mil
- ③ BCL 900i SM 102 0.50 mm/20 mil

Figure 53 – Reading diagram – BCL 900i SM 102 combined

BCL 900i SM 102 0.33 mm/13 mil

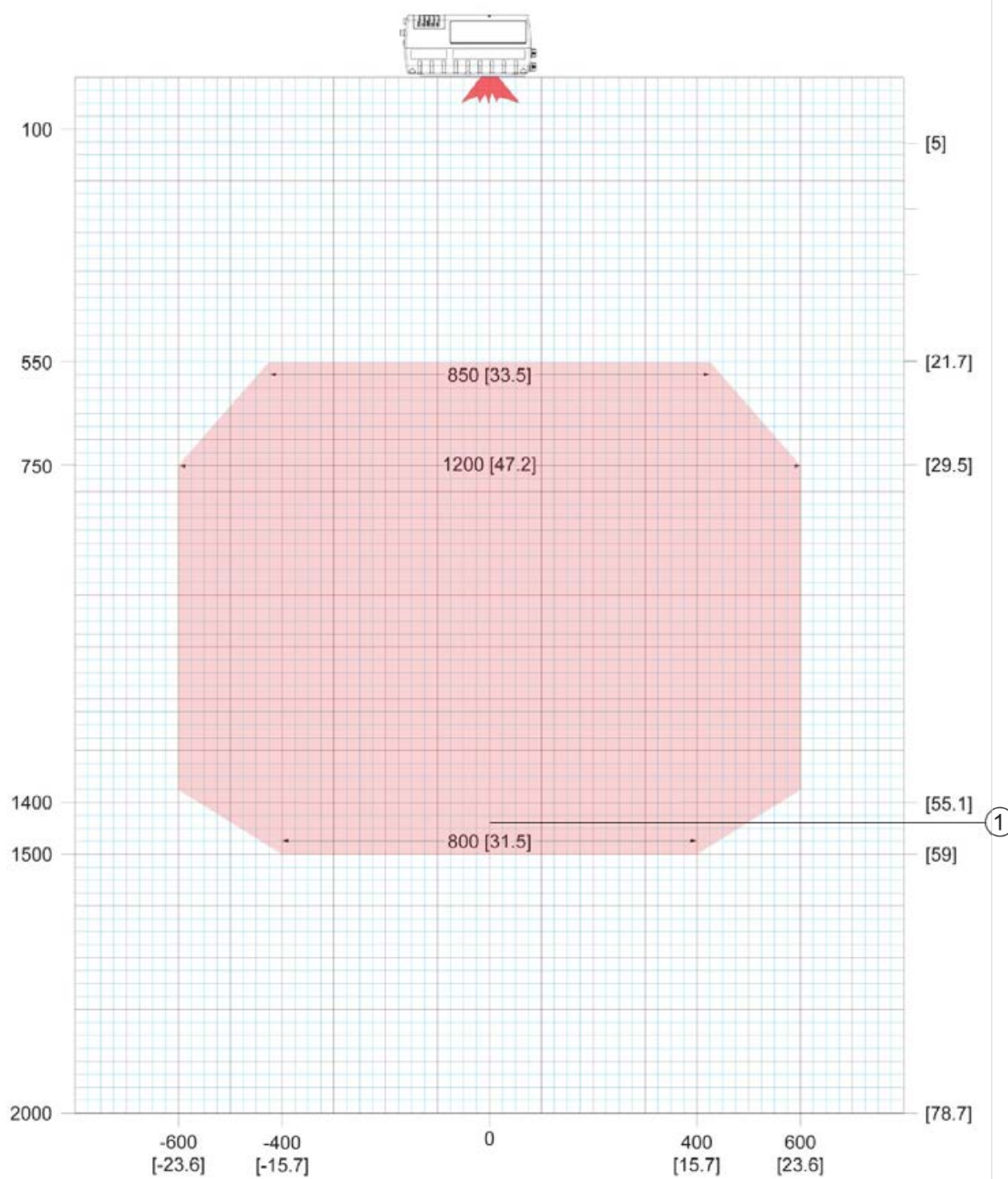

1,000 scans per second (standard) over entire DOF
 ANSI contrast grade 84 % or greater
 ANSI "Grade A" print quality

Pitch not greater than +/- 15°
 Skew not greater than +/- 15°
 Tilt not greater than +/- 45°

① BCL 900i SM 102 0.33 mm/13 mil

Figure 54 – Reading diagram, BCL 900i SM 102 0.33 mm/13 mil

BCL 900i SM 102 0.38 mm/15 mil

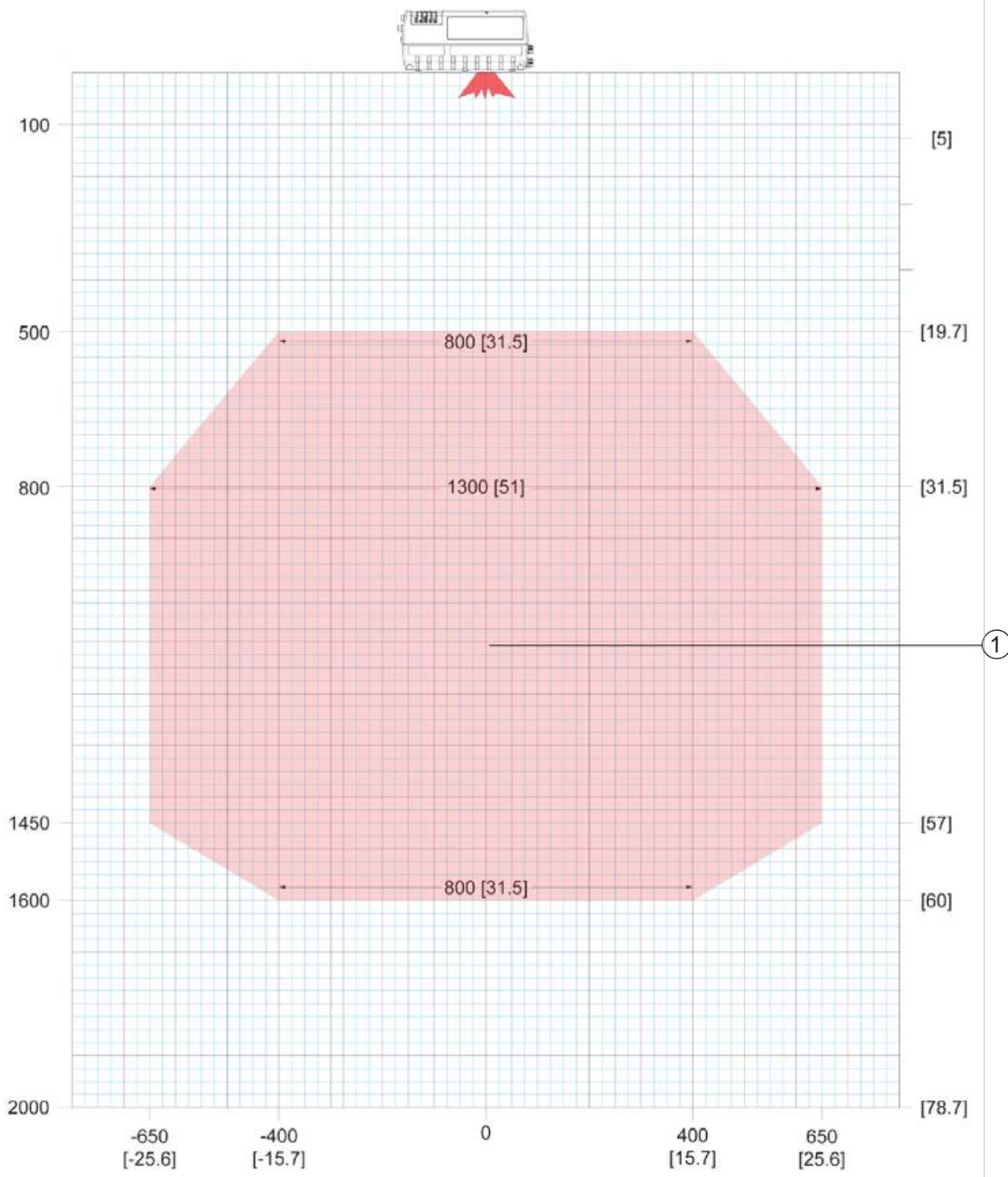

1,000 scans per second (standard) over entire DOF
 ANSI contrast grade 84 % or greater
 ANSI "Grade A" print quality

Pitch not greater than +/- 15°
 Skew not greater than +/- 15°
 Tilt not greater than +/- 45°

① BCL 900i SM 102 0.38 mm/15 mil

Figure 55 – Reading diagram, BCL 900i SM 102 0.38 mm/15 mil

BCL 900i SM 102 0.50 mm/20 mil

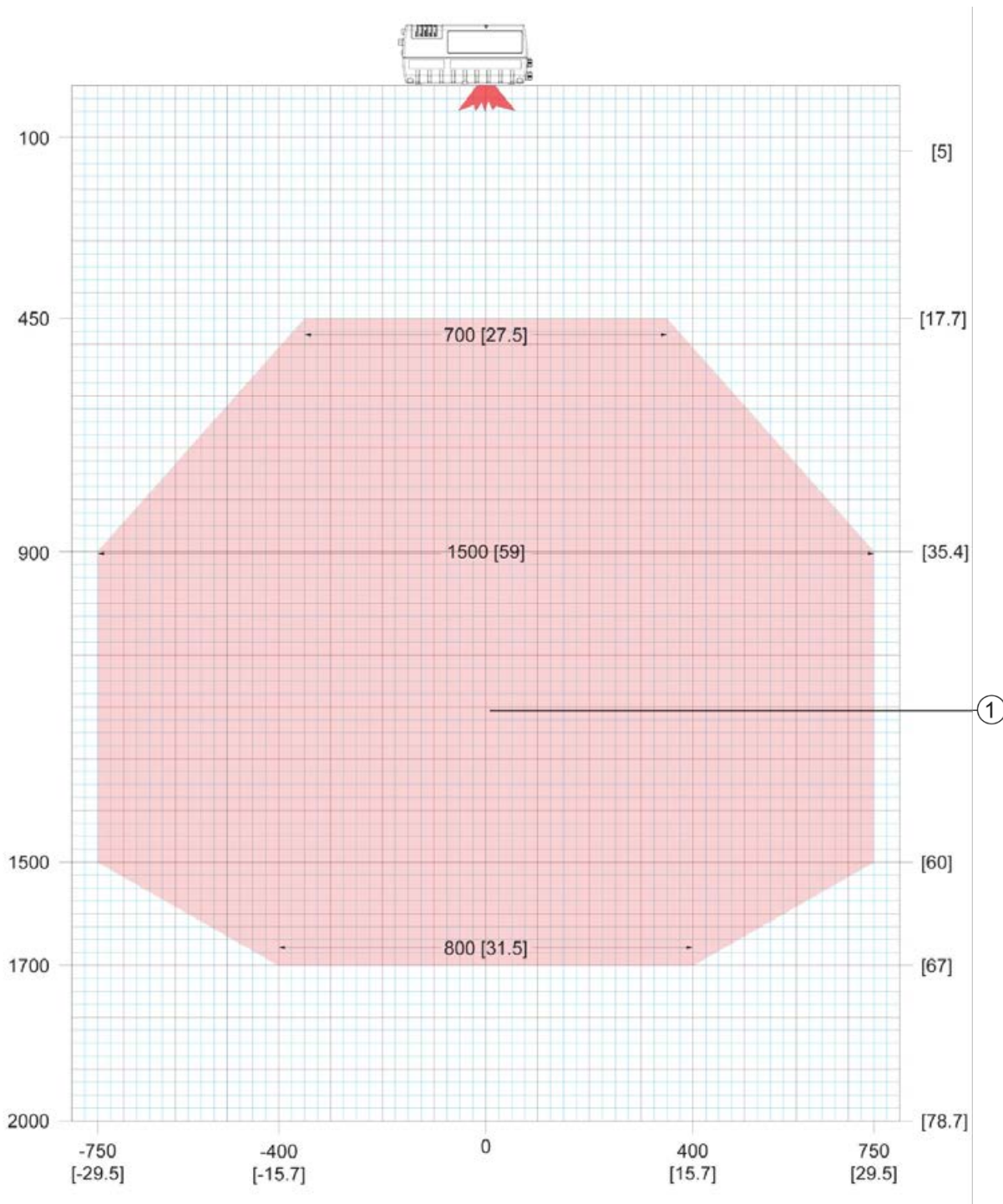

1,000 scans per second (standard) over entire DOF
 ANSI contrast grade 84 % or greater
 ANSI "Grade A" print quality

Pitch not greater than +/- 15°
 Skew not greater than +/- 15°
 Tilt not greater than +/- 45°

① BCL 900i SM 102 0.50 mm/20 mil

Figure 56 – Reading diagram, BCL 900i SM 102 0.50 mm/20 mil

BCL 900i SN 102

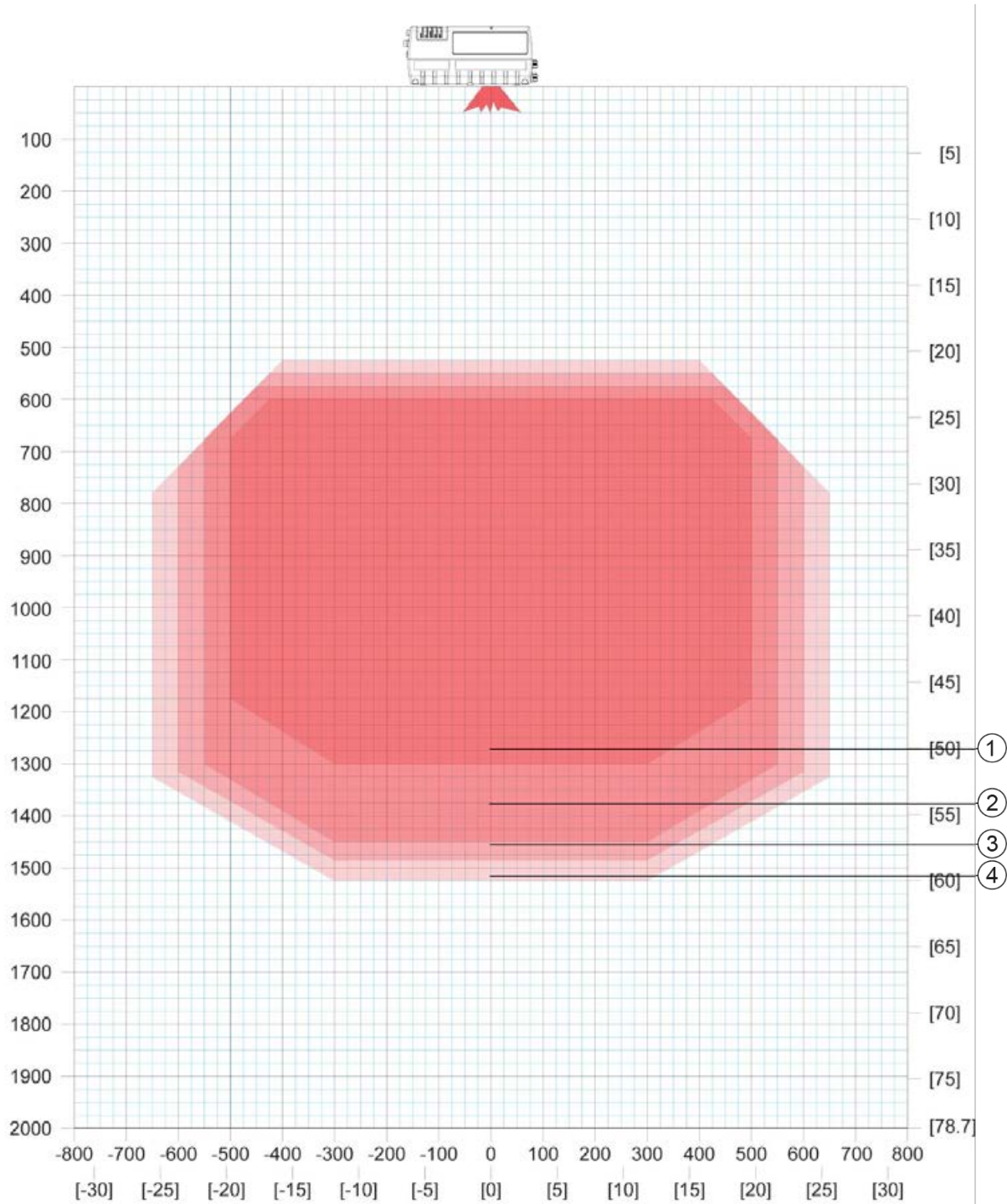

1,000 scans per second (standard) over entire DOF
 ANSI contrast grade 84 % or greater
 ANSI "Grade A" print quality

Pitch not greater than +/- 15°
 Skew not greater than +/- 15°
 Tilt not greater than +/- 45°

- ① BCL 900i SN 102 0.25 mm/10 mil
- ② BCL 900i SN 102 0.30 mm/12 mil
- ③ BCL 900i SN 102 0.33 mm/13 mil
- ④ BCL 900i SN 102 0.38 mm/15 mil

Figure 57 – Reading diagram, BCL 900i SN 102 combined

BCL 900i SN 102 0.25 mm/10 mil

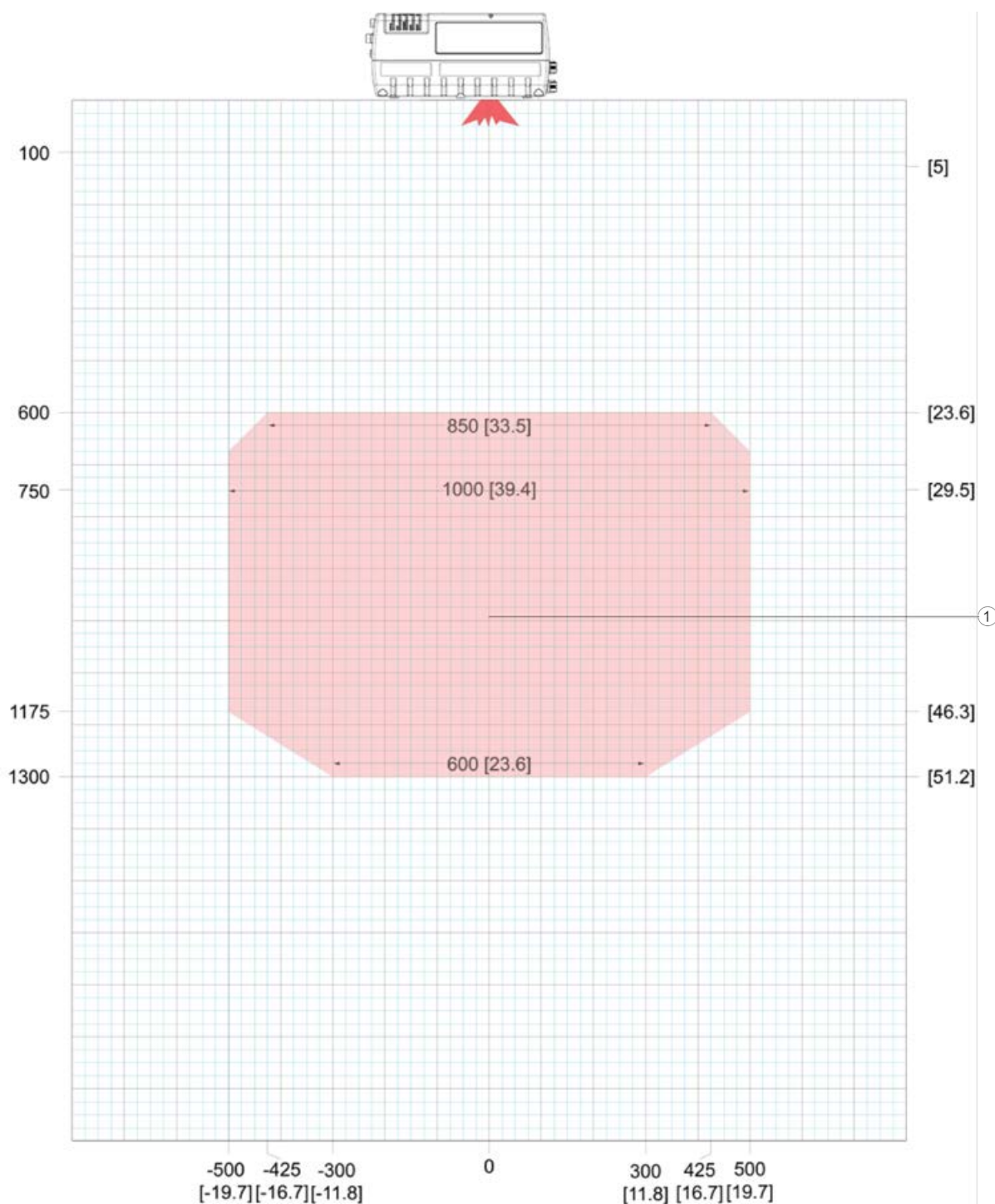

1,000 scans per second (standard) over entire DOF
 ANSI contrast grade 84 % or greater
 ANSI "Grade A" print quality

Pitch not greater than +/- 15°
 Skew not greater than +/- 15°
 Tilt not greater than +/- 45°

① BCL 900i SN 102 0.25 mm/10 mil

Figure 58 – Reading diagram, BCL 900i SN 102 0.25 mm/10 mil

BCL 900i SN 102 0.30 mm/12 mil

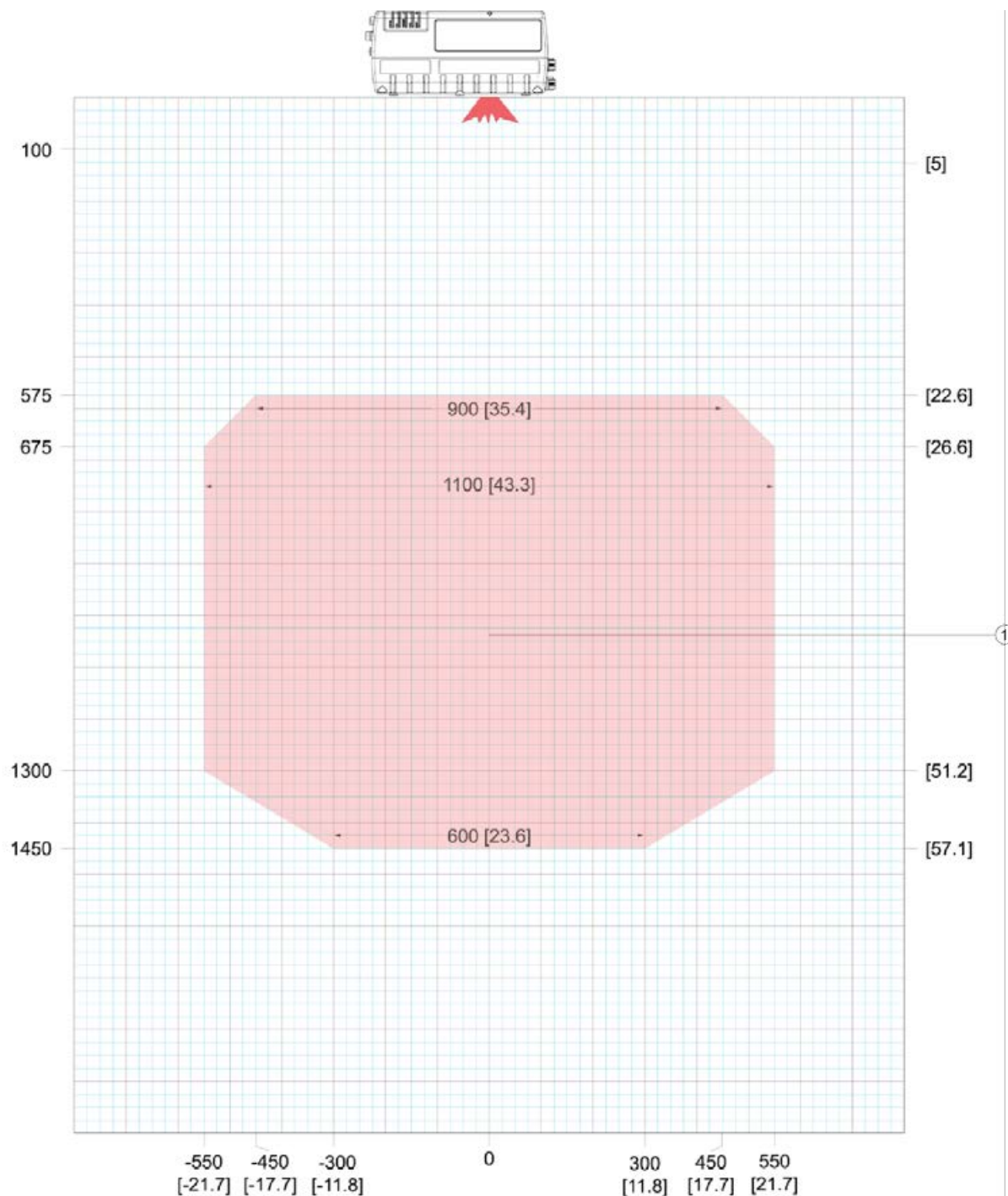

1,000 scans per second (standard) over entire DOF
 ANSI contrast grade 84 % or greater
 ANSI "Grade A" print quality

Pitch not greater than +/- 15°
 Skew not greater than +/- 15°
 Tilt not greater than +/- 45°

① BCL 900i SN 102 0.30 mm/12 mil

Figure 59 – Reading diagram, BCL 900i SN 102 0.30 mm/12 mil

BCL 900i SN 102 0.33 mm/13 mil

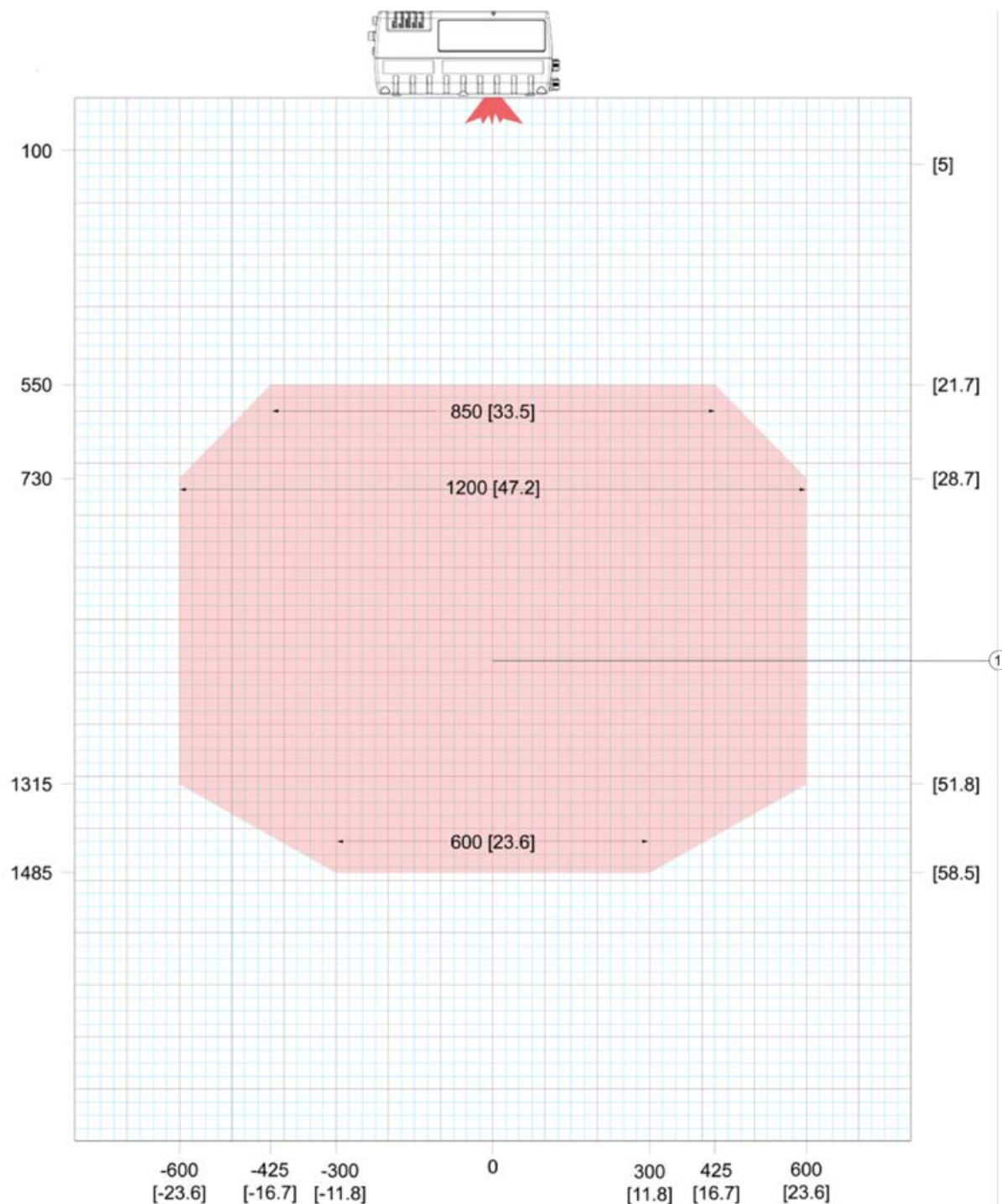

1,000 scans per second (standard) over entire DOF
 ANSI contrast grade 84 % or greater
 ANSI "Grade A" print quality

Pitch not greater than +/- 15°
 Skew not greater than +/- 15°
 Tilt not greater than +/- 45°

① BCL 900i SN 102 0.33 mm/13 mil

Figure 60 – Reading diagram, BCL 900i SN 102 0.33 mm/13 mil

BCL 900i SN 102 0.38 mm/15 mil

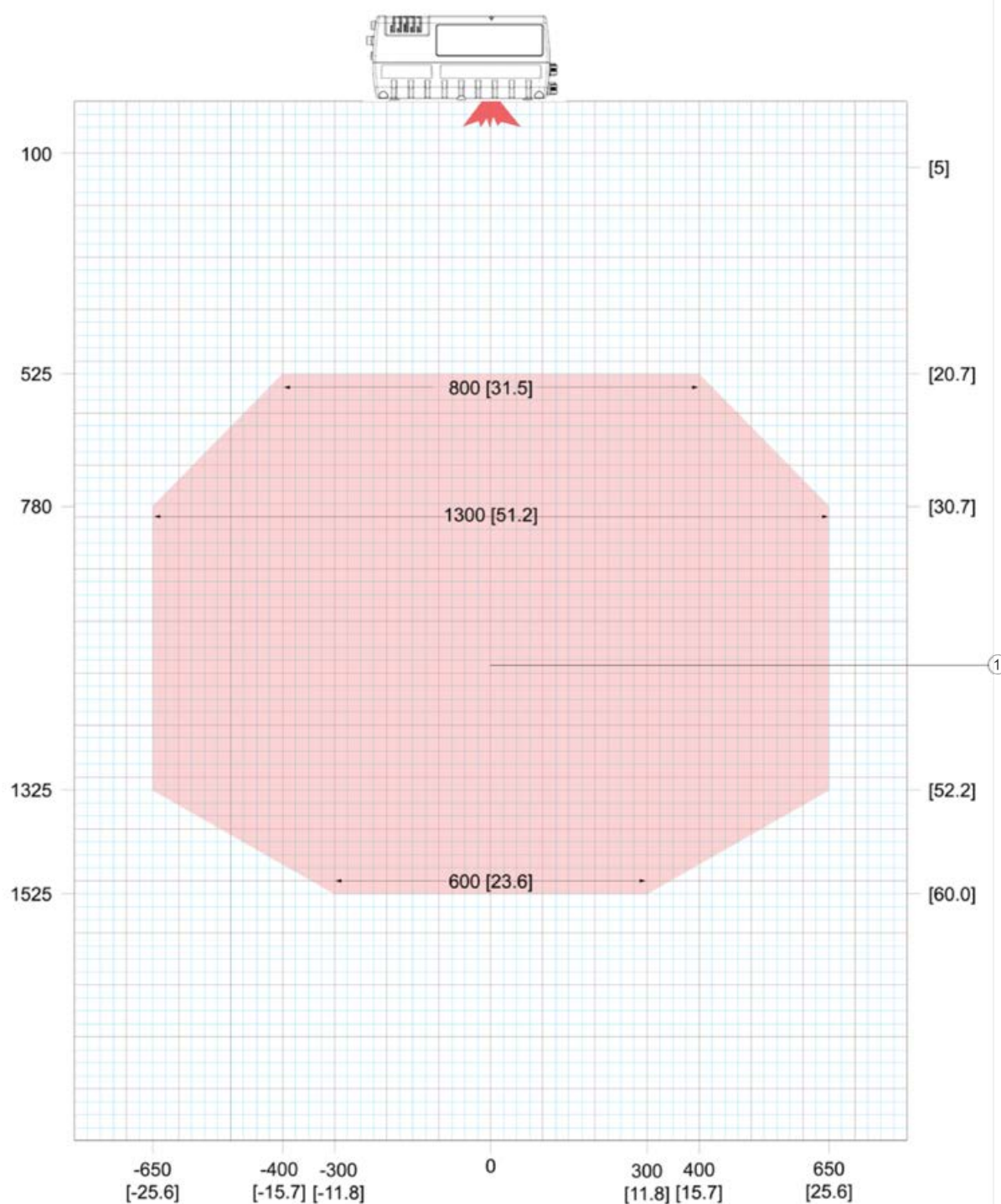

1,000 scans per second (standard) over entire DOF
 ANSI contrast grade 84 % or greater
 ANSI "Grade A" print quality

Pitch not greater than +/- 15°
 Skew not greater than +/- 15°
 Tilt not greater than +/- 45°

① BCL 900i SN 102 0.38 mm/15 mil

Figure 61 – Reading diagram, BCL 900i SN 102 0.38 mm/15 mil

6 MAINTENANCE

6.1 OVERVIEW

This chapter provides instructions to ensure optimum performance and service life of your BCL 900i bar code scanner. It provides specific information on:

- Maintenance procedures
- Exterior cleaning
- Mounting hardware checks
- Wiring connection checks

Position	Description
Soft-bristled brush	For cleaning the outside of the device
Clean, soft cloths	For cleaning the outside of the device
Cleaning solutions	Mild detergent solutions for cleaning the outside of the device Solution of 70% denatured alcohol and 30% de-ionized water for cleaning exit window
Soft cotton swabs or lint-free cloth	For cleaning the exit window of the bar code scanner



IMPORTANT: due to the complex and application-specific nature of these installations, the bar code scanner must be set up and serviced by authorized technicians trained by Leuze electronic.

THE MAINTENANCE PROCEDURES IN THIS CHAPTER MAY BE PERFORMED BY A TECHNICIAN PROVIDED BY THE END USER. TRAINING IS RECOMMENDED IF THE END USER INTENDS TO CARRY OUT PROCEDURES BEYOND THOSE DESCRIBED IN THIS CHAPTER.

THERE ARE NO USER-SERVICEABLE PARTS IN THE BAR CODE SCANNER.

DO NOT OPEN THE DEVICE. OPENING THE BAR CODE SCANNER MAY VOID ITS WARRANTY.

CAUTION: PERFORMING ANY SETUP, CALIBRATION OR SERVICE PROCEDURES WITHOUT PROPER TRAINING MAY VOID THE WARRANTY.

FOR FURTHER INFORMATION ON TRAINING, CONTACT US THROUGH OUR WEBSITE AT www.leuze.com.

6.2 MAINTENANCE TASKS

Perform the maintenance tasks on an "as needed" basis to ensure correct operation of the bar code scanner. The frequency of the scheduled tasks depends on the conditions in the application environment. Each maintenance task requires only a few minutes.

Exterior cleaning



WARNING: shut down the scanner before performing this maintenance task. Do not stare at the laser light in the scanner's exit window. Avoid direct eye exposure. The laser light level does not constitute a health hazard; however, staring at the laser light for prolonged periods can result in eye damage.



CAUTION: do not use any chemicals on the scanner that are unsafe for plastics, such as benzene, acetone or similar products. Before performing this maintenance task, be sure to shut down the device.

The exterior cleaning procedure may be performed without removing the reader from the mounting structure.

1. Switch off the bar code scanner by disconnecting the power supply line.
2. Clean the exterior (except the exit window) with a clean, soft-bristled brush. Be sure not to brush any dust, dirt or other residue onto the exit window.
3. Carefully remove all residue on or around the exit window.
4. Wipe the exterior (except the exit window) with a clean, soft cloth dampened slightly with a mild detergent solution.
5. The exit window should be cleaned after this task is completed.

6.2.1 Cleaning the exit window

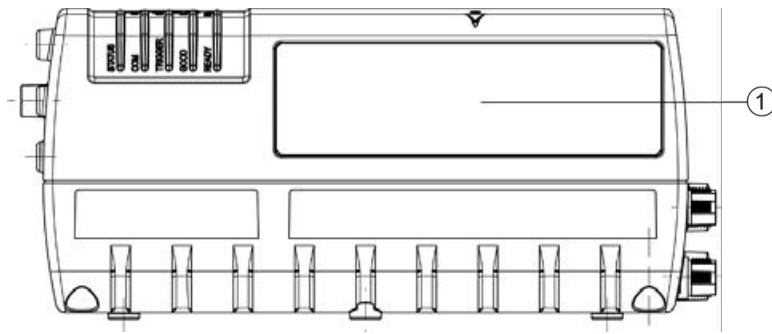

① Exit window

Figure 62: Position of exit windows



WARNING: shut down the scanner before performing this maintenance task. Do not stare at the laser light in the scanner's exit window. Avoid direct eye exposure. The laser light level does not constitute a health hazard; however, staring at the laser light for prolonged periods can result in eye damage.



CAUTION: never apply cleaning solution directly to the exit window. Always apply the solution to a cloth and then clean the window using the cloth. Do not use any chemicals on the barcode scanner that are unsafe for plastics, such as benzene, acetone or similar products.

The exit window cleaning procedure may be performed without removing the reader from the mounting structure if it is possible to do so.

1. Switch off the scanner by disconnecting the power supply line.
2. Perform the exterior cleaning procedure before cleaning the exit window.
3. Check the exit window surface for dust, dirt or smudges. If the window needs to be cleaned, proceed to step 4.
4. Make a cleaning solution of seven parts denatured alcohol and three parts water.
5. Apply the cleaning solution to a cotton swab or lint-free cloth.
6. Use this to apply the cleaning solution to the exit window.
7. Remove any streaks or remaining moisture from the exit window with a dry, soft, lint-free cloth or lens paper.
8. Check operation of the scanner.

6.2.2 Cleaning the photoelectric sensor

If your application uses the photoelectric sensor option as a hardware trigger, be sure to clean the photoelectric sensor periodically as outlined below.

1. Switch off the product transport.
2. Switch off the scanner by disconnecting the power supply line.
3. Clean the lens of the photoelectric sensor using the denatured alcohol solution and a cotton swab or lens paper.
4. Clean the reflector using the denatured alcohol solution and a cotton swab or lens paper.
5. Check that the photoelectric sensor operates correctly.

6.2.3 Cleaning the rotation encoder

If your application uses the rotation encoder option for tracking purposes, be sure to clean the wheels of the rotation encoder periodically as outlined below.

1. Switch off the product transport.
2. Switch off the scanner by disconnecting the power supply line.
3. Wipe down the wheels of the rotation encoder with a mild detergent solution using a clean, soft cloth.
4. Before restarting the system, be sure that the rotation encoder is making good contact with the product transport.
5. Check that the rotation encoder operates correctly.



Figure 63: Rotation encoder wheel

6.2.4 Tightening mounting hardware

1. Check the mounting hardware of the bar code scanner, MA connection unit (if applicable), MSC 900 controller (if applicable) and power supply as necessary. Tighten the fastening elements as necessary. Do not over-tighten. Take care to not to disturb the device alignment as this is linked to the product transport.
2. Check the mounting hardware of the photoelectric sensor (if this option is being used). Tighten the fastening elements as necessary. Do not over-tighten.
3. Check the mounting hardware of the rotation encoder (if this option is being used). Tighten the fastening elements as necessary. Do not over-tighten.

6.2.5 Checking bar code scanning system connections

The connections to the bar code scanners run between the connection field and MA connection unit and/or MSC 900 controller.

(See *Chapter 3, Electrical installation.*)

1. Check all cable connections to the connection field. Tighten any loose connections as necessary. Do not over-tighten.
2. Check all cable connections to the MA connection unit and/or the MSC 900 controller. Tighten any loose connections as necessary. Do not over-tighten.
3. Check all cables/cable ducts for signs of wear or damage. Repair or replace any damaged cable connections as necessary.

6.2.6 Checking bar code scanner operation

If after maintenance the performance of the bar code scanning system is below that achieved in normal operation under normal daily conditions, contact Leuze electronic through our website at www.leuze.com.

6.2.7 Checking photoelectric sensor operation

1. Block the beam emitted from the photoelectric sensor to confirm that it is aligned properly with the reflector.
2. Check that the TRIGGER LED on the bar code scanner lights up YELLOW when the photoelectric sensor beam is blocked.

If the photoelectric sensor LED does not change status, adjust the photoelectric sensor so that it is properly aligned with the reflector.

If the TRIGGER LED on the bar code scanner does not light up green when the photoelectric sensor beam is blocked, check the wiring between the photoelectric sensor and MA 900 or MSC 900 for damage.

6.2.8 Checking rotation encoder operation

Rotate the rotation encoder wheel slowly.

The **ENC/TACH** LED in the MA 900 or the **TACH** LED on the MSC 900 should flash indicating that the rotation encoder is operational. You can also view the belt speed by navigating to **Diagnostics | Monitor** in the user interface (see section 4.7.1).

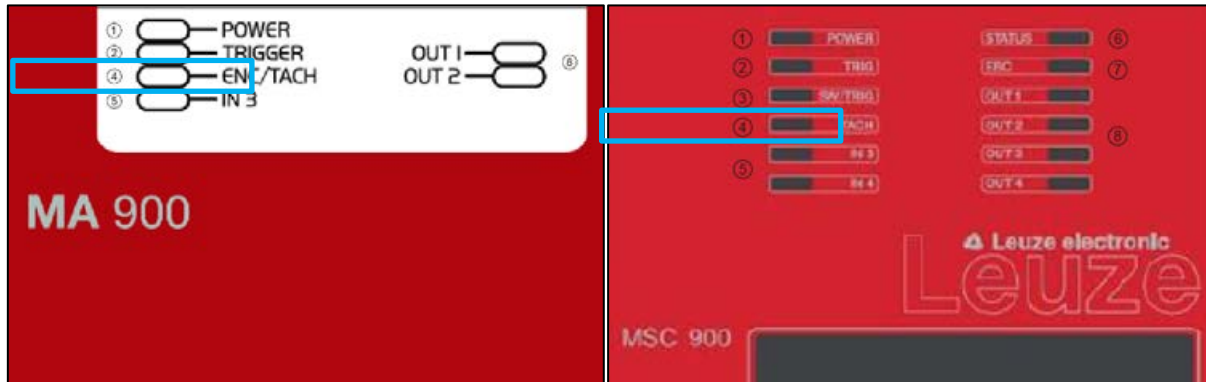

- ① POWER
- ② TRIGGER/TRIG
- ③ SW/TRIG
- ④ ENC/TACH
- ⑤ IN 3 - IN 4
- ⑥ STATUS
- ⑦ EBC
- ⑧ OUT1 – OUT 4

Figure 64: ENC/TACH LED indicators in MA 900 and MSC 900

If these indicators do not register feedback when the rotation encoder wheel is rotated, check the wiring between the rotation encoder and the MA 900 for damage.

7 TROUBLESHOOTING



IMPORTANT: due to the complex and application-specific nature of these installations, operational deficiencies of the bar code scanner must be diagnosed and serviced by technicians who have been trained and authorized by Leuze electronic.

There are no user-serviceable components or field-replaceable units (FRUs) inside the bar code scanner.

For further information on training, contact us through the Leuze electronic website at www.leuze.com.



NOTE: when contacting Leuze electronic for help with a scanner, please have the serial number of the device to hand ready to give to the Leuze electronic technician. The serial number tag is located on the device as shown below. The contact information for the help desk is available at www.leuze.com

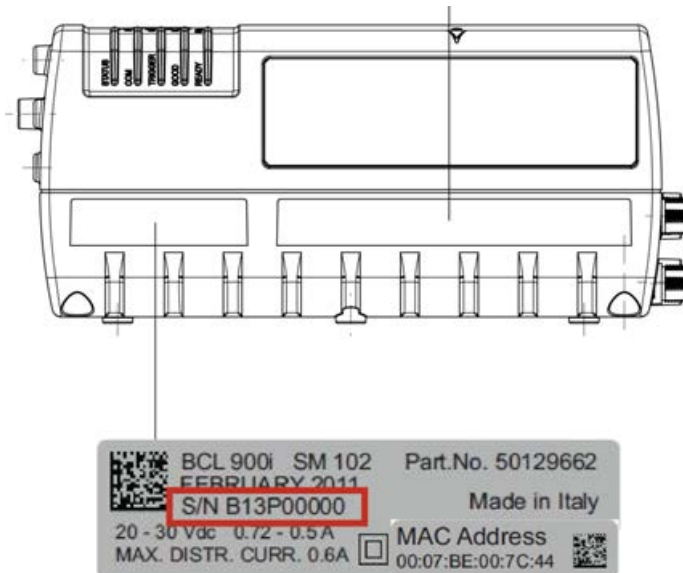

Figure 65: Location of serial number label

7.1 ERROR CODES AND RESOLUTIONS

Error code	Description	Severity	Explanation	Symptom	Troubleshooting	Action required
1	Node not responding	Error	In a master/slave configuration, the master monitors the status of the slaves in its network. If a slave unit fails to be identified, the master will send this message.	<ul style="list-style-type: none"> - The NOREAD rate of the scanning tunnel increases. - More than one slave unit may be shown as not responding. 	<ul style="list-style-type: none"> - In a tunnel configuration, the wiring that connects the system to a network must be intact or a scanner will be reported as not responding. - Make sure that all the slave units are switched on. 	<ul style="list-style-type: none"> - Make sure that the cables are connected. - Check the power supply of the scanners. - Replace the scanner.
80	Node reset	Error	In a master/slave configuration, the master monitors the status of the slaves in its network. If a slave resets, it sends a reset message to the master. The master then displays this error state on the diagnostic screen.	<ul style="list-style-type: none"> - The NOREAD rate of the scanning tunnel may increase while the slave scanner is being reconnected. 	<ul style="list-style-type: none"> - This state relates to a slave scanner. Make sure that the power supply of the slave is not faulty. 	<ul style="list-style-type: none"> - If the state persists, replace the scanner.
81	Motor failure	Error	The motor of the scanner mirror wheel has failed.	<ul style="list-style-type: none"> - The scanner is powered up but does not emit laser light from its exit window. - The motor of the scanner does not run. 	<ul style="list-style-type: none"> - Hold your hand in front of the scanner to determine whether the laser is switched on. 	<p>This is an internal failure and is not field-serviceable.</p> <ul style="list-style-type: none"> - Replace the scanner.
83	Laser failure	Error	The laser of the scanner has failed.	<ul style="list-style-type: none"> - No laser light is emitted from the scanner. - The motor of the mirror wheel may still run, but the motor speed may be out of range, which causes the scanner to switch off the laser light. 	<ul style="list-style-type: none"> - Hold your hand in front of the scanner to determine whether the laser is switched on. 	<p>This is an internal failure and is not field-serviceable.</p> <ul style="list-style-type: none"> - Replace the scanner.

Error code	Description	Severity	Explanation	Symptom	Troubleshooting	Action required
130	Encoder timeout	Warning	<p>No encoder (rotation encoder) is detected in the specified time. The encoder signal provides the scanner with the belt speed and other tracking information.</p> <p>This error only occurs when the scanner is in PackTrack operating mode.</p>	<ul style="list-style-type: none"> - The scanner may register an increase in no-reads. - The scanner may start missing the transmit point. 	<ul style="list-style-type: none"> - Make sure that the belt is running. - Make sure that the encoder (rotation encoder) makes firm contact with the conveyor belt. - Check under Global settings Diagnostics Encoder timeout that the setting is not too low (see section 4.5.8). 	<ul style="list-style-type: none"> - Adjust the mounting of the encoder (rotation encoder). - Adjust the Encoder timeout setting (see section 4.5.8).
131	Input 1 failure	Error	<p>The primary photoelectric sensor input is stuck in the active state (PackTrack mode).</p>	<ul style="list-style-type: none"> - The scanner is not triggered. - No data is transmitted to the host. 	<ul style="list-style-type: none"> - Check the alignment of the photoelectric sensor. - Check the functionality of the photoelectric sensor. 	<ul style="list-style-type: none"> - Realign the photoelectric sensor. - Replace the photoelectric sensor.
132	"No phase" error	Error	<p>The "No phase" timeout is exceeded (On-Line and PackTrack mode).</p> <ul style="list-style-type: none"> - The trigger must be identified within a specified time. 			
133	Input 2 failure	Error	<p>The secondary photoelectric sensor input has failed and is stuck in the active state (PackTrack mode).</p>	<ul style="list-style-type: none"> - The scanner is not triggered. - No data is transmitted to the host. 	<ul style="list-style-type: none"> - Check the alignment of the photoelectric sensor. - Check the functionality of the photoelectric sensor. 	<ul style="list-style-type: none"> - Realign the photoelectric sensor. - Replace the photoelectric sensor.

Error code	Description	Severity	Explanation	Symptom	Troubleshooting	Action required
135	Encoder failure	Error	The phase input (trigger source) is activated while the encoder (rotation encoder) is stationary (PackTrack mode).	<ul style="list-style-type: none"> - No data is transmitted to the host. - The scanner(s) does/do not read any bar codes. - The system receives a trigger cycle if no encoder signal is present. 	<ul style="list-style-type: none"> - Check Diagnostics Monitor to see whether the scanner is reporting a conveyor speed (see section 4.7.1). - Make sure that the encoder (rotation encoder) makes firm contact with the conveyor belt. 	<ul style="list-style-type: none"> - Adjust, realign or replace the encoder (rotation encoder).
157	SD card failure	Error	<p>MSC 900 – The SD card cannot be accessed. The SD card contains the backup files. It also contains a copy of the scanner application software.</p> <p>This failure occurs only in the MSC 900.</p>	<ul style="list-style-type: none"> - The device does not back up or restore the parameters. 	<p>Try to save the parameters from the MSC 900 to the SD card (see the <i>MSC 900 system controller reference manual</i>).</p>	<ul style="list-style-type: none"> - Make sure that the SD card is seated properly in the MSC 900. - Replace the SD card (see the <i>MSC 900 system controller reference manual</i>).
169	Main serial port error	Error	Protocol index message not received on the main serial port.			
176	Aux serial port error	Error	Protocol index message not received on the aux serial port.			
178	Ethernet socket 1 error	Error	Protocol index message not received on user socket 1.			
179	Ethernet socket 2 error	Error	Protocol index message not received on user socket 2.			
180	Ethernet socket 3 error	Error	Protocol index message not received on user socket 3.			
181	Ethernet socket 4 error	Error	Protocol index message not received on user socket 4.			
182	Ethernet socket 5 error	Error	Protocol index message not received on user socket 5.			
183	Ethernet socket 6 error	Error	Protocol index message not received on user socket 6.			

Error code	Description	Severity	Explanation	Symptom	Troubleshooting	Action required
191	Fieldbus mismatch	Error	The fieldbus module type does not match the specified model. - The selected module does not match the module actually installed.			
193	Fieldbus config error	Error	Error during configuration of the fieldbus module.	- Communication with the module not possible.	- Make sure that the device is not communicating with the host. - Make sure that the fieldbus parameters are configured properly (<i>see section 4.5.7</i>).	- Replace the fieldbus module.
195	Fieldbus DHCP error	Error	A DHCP error has occurred on the PROFINET module.	- IP address acquisition not possible.	- Make sure that the device is not communicating with the host. - Make sure that the fieldbus parameters are configured properly (<i>see section 4.5.7</i>).	- Replace the fieldbus module.
205	APD temperature Error	Error	The APD temperature sensor is not working. A fluctuation in scanner temperature can have an adverse effect on several internal functions of the scanner. The scanner monitors the temperature and reports this error if it detects an anomaly.	- The scanner may register an increase in no-reads. - The scanner may start missing the transmit point.	1. Switch the scanner off and on again. 2. Wait until the device has cooled down. 3. Restart the scanner and monitor it to determine whether the error reoccurs.	This is an internal failure and is not field-serviceable. - Replace the scanner.
207	In-beam sensor error	Error	The scanner has an in-beam sensor, which provides the timing for the decoding of bar codes. The scanner monitors this signal and reports this error if the signal is sporadic or missing.	- The scanner stops reading bar codes.	- Put the scanner in the test mode to test whether it is able to read the bar code (<i>see section 4.7.2</i>).	This is an internal failure and is not field-serviceable. - Replace the scanner.

Error code	Description	Severity	Explanation	Symptom	Troubleshooting	Action required
211	PTP error	Error	Synchronization of the internal clock using the PTP (precision time protocol) not possible. This clock sync pulse is generated by the controller unit. It is used to sync the read data of all the scanners in the network with the master unit.	LEDs flashing.	<ul style="list-style-type: none"> - Make sure that all scanners are connected to the chain. - Use the scanner test mode to confirm that the scanner can statically read a bar code (see section 4.7.2). - Position a bar code on a box so that it faces the scanner concerned, and dynamically test the scanner. 	<ul style="list-style-type: none"> - Replace the faulty scanner.
219	Fieldbus communication error	Error	No communication with the fieldbus module possible.	<ul style="list-style-type: none"> - The host loses communication with the scanner. 	<ul style="list-style-type: none"> - Make sure that the device is not communicating with the host. - Make sure that the fieldbus parameters are configured properly (see section 4.5.7). 	<ul style="list-style-type: none"> - Replace the fieldbus module.
220	Network ring open	Error	When the MSC 900 is used, the internal scanner network is connected in a chain configuration. If the MSC 900 detects that the network chain is not complete, it reports this error.	<ul style="list-style-type: none"> - The system is experiencing a high NO READ rate. - One or more scanners may not appear on the System Info page (see section 4.4). 	<ul style="list-style-type: none"> - Make sure that all scanners are connected to the chain. - Use the scanner test mode to confirm that the scanner can statically read a bar code (see section 4.7.2). - Position a bar code on a box so that it faces the scanner concerned, and dynamically test the scanner. 	<ul style="list-style-type: none"> - Replace the faulty scanner.

8 TECHNICAL FEATURES

This chapter provides detailed specifications for the BCL 900i bar code scanning systems. It provides specific information on:

- Electrical features
- Optical features
- Reading features
- Human-machine interface
- Software features
- Environmental features
- Physical features

8.1 TECHNICAL SPECIFICATIONS

ELECTRICAL FEATURES					
Supply voltage	20-30VDC				
Power consumption	0.72-0.5A (note: 1.3A max peak current at motor start-up) 20 W typical				
Common communication interfaces	<table border="1"> <thead> <tr> <th>Main port</th> <th>Baud rate</th> </tr> </thead> <tbody> <tr> <td>RS232/RS422 up to 115.2 Kbit/s</td> <td>1200 to 115200</td> </tr> </tbody> </table>	Main port	Baud rate	RS232/RS422 up to 115.2 Kbit/s	1200 to 115200
	Main port	Baud rate			
	RS232/RS422 up to 115.2 Kbit/s	1200 to 115200			
<table border="1"> <thead> <tr> <th>Auxiliary port</th> <th></th> </tr> </thead> <tbody> <tr> <td>RS232 up to 115.2 Kbit/s</td> <td>1200 to 115200</td> </tr> </tbody> </table>	Auxiliary port		RS232 up to 115.2 Kbit/s	1200 to 115200	
Auxiliary port					
RS232 up to 115.2 Kbit/s	1200 to 115200				
Ethernet	2 x Ethernet TCP/IP				
Digital inputs	3 x inputs (2 + 1 x "encoder"), optocoupled, NPN/PNP				
Digital outputs	2 x outputs, SW-programmable, optocoupled, event-driven, NPN				
Internal communication system	EBC technology				
Integrated fieldbus	Ethernet TCP/IP and UDP, Ethernet/IP, PROFIBUS and PROFINET are supported				
OPTICAL FEATURES					
Wavelength	630 to 680 nm				
Laser class	2, IEC 60825-1:2014 / EN 60825-1:2014+A11:2021				
Light source	Red laser diode				
Laser control	Safety system to switch off the laser if the motor speed drops				
Focusing system	Fixed focus position				

READING FEATURES	
Scanning rate	Typ.: 1000 scans/s max.
Maximum resolution	Min: 0.25 mm (10 mils) / max: 0.50 mm (20 mils)
Max. reading distance	See 5.10 Reading diagrams
Max. reading field width	See 5.10 Reading diagrams
Max. depth of field	See 5.10 Reading diagrams
Aperture angle	60 degrees
Scan pattern type	Linear

HUMAN-MACHINE INTERFACE	
Keypad	2 keys
LED indicators	Status, Com, Trigger, Good, Ready, Test, Learn, Setup, Netconfig

SOFTWARE FEATURES	
Device programming	Multilanguage, browser-based, on-board HTML web server interface
Readable bar codes	22 symbologies including 2/5 family, Code39, Code93, Code128, EAN/UPC, EAN128, ISBN128
Multilabel reading	Up to 10 different symbologies during the same reading phase
Headers and terminators	Up to 128-byte headers and 128-byte terminators
Operating modes	On Line, Test, PackTrack™, Continuous
Bar code assignment technology	PackTrack
Code reconstruction technology	CRT
Parameter storage	Non-volatile internal FLASH memory

ENVIRONMENTAL FEATURES	
Temperature	Operating: 0 to 50 °C (32 to 122 °F) Storage: -20 to 70 °C (-4 to 158 °F)
Relative humidity	10-90% non-condensing
Ambient light sensitivity	> 30,000 lux
Vibration resistance ①	<ul style="list-style-type: none"> • SINE vibration as per EN60068-2-6 • 2-10 Hz: 14 mm / 13-55 Hz: 1.5 mm / 70-500 Hz: 2 g • 2 h per axis / 3 axes
Shock resistance	As per EN60068-2-27, 30 g / 11 ms / 3 times up and 3 times down on each axis / 3 axes
Degree of protection	IP65

PHYSICAL FEATURES	
Dimensions	216 x 96 x 127 mm [8.5 x 3.8 x 5 in]
Weight	2.0 kg (4.4 lb)
Housing	Aluminum alloy
Connections	I/O, POWER, ETH1, ETH2; other connections via MA 900
OTHER	
Service options	Installation services and on-site training
Warranty	2-year limited, parts and labor

① Product not installed on mounting bracket provided.

Index

- Accessories 4
- Applications 1
- Backup 148
- Barcode configuration 73
 - code collection 90
 - logical combination 82
 - single label 74
 - standard multi label 78
- Barcode scanning functions 153
- Barcode settings table 68
- Caution
 - ESD vii
 - high voltage vii
 - laser vii
- CE conformity ix
- Commissioning
 - initial 153
- Conformity vii
- Connecting a laptop 28
- Connection 21
 - typical 22
- Connection field
 - BCL 900i 27
- Conventions vii
- CRT 195
- Device description 2
- Device settings 134
 - device info 135
 - mounting 137
 - options 139
- Diagnosis 141
- Diagnostics 128
- Diagnostics
 - monitor 142
- Diagnostics
 - read test 144
- Diagnostics
 - status viewer 145
- Digital I/O 125
- Electrical
 - disconnect device, readily accessible 29
 - protective grounding 29
 - recommended installation sequence 28, 170, 171, 178, 188, 216
 - safety precautions when working with high voltages 29
- Electrical installation 20
 - guidelines 26
- Electrical safety vii
- Energy saving 129
- Ethernet
 - Ethernet/IP 102
 - line settings 99
 - user sockets 100
 - WebSentinel 104
- Ethernet 98
- External function keys 3
- FCC compliance x
- General view xi
- Global settings 53
- HMI 3, 133
- Human Machine Interface 3, 133
- Installation
 - checking 43
 - recommended sequence 28, 170, 171, 178, 188, 216
- Installation sequence 11
- Introduction 1
- Laptop
 - connecting 28
- Laser safety vii
- Laser warning notices vii
- LED indicators 161
- MA 900
 - photoelectric sensor connection 32
 - relay configuration 39
- MA 900, connections 30
- MA connection unit
 - connecting the rotation encoder 35
- Maintenance 209
- Mechanical installation 9
- Messaging
 - message format 105
- Messaging 105
- Messaging
 - message builder 112
- Messaging
 - statistics 116
- Messaging
 - protocol index 118
- Messaging
 - Pass-Thru 121
- Modify settings 49
- Monitor 142
- Mounting specifications 166
- MSC 900, connections 42
- Operating mode 54
- PackTrack
 - checking calibration 186
 - side-mounted scanner 178
 - top-mounted scanner 171
- PackTrack calibration wizard 138
- PackTrack calibration wizard 166
- PackTrack Wizard 166, 168
- Pass-Thru 121
- Patents vi
- Performance 197
- Please note vii
- Power supply ix
 - disconnect device, readily accessible 29
 - requirements 29
- Power supply connections 29
- Read test 144
- Reading diagrams 199
- Reboot 150
- References vi
- Restore 148
- Rotation encoder

Index

- connecting 35
 - NPN output, wiring 35
 - PNP output, wiring 37
- Serial ports 94
 - aux port 96
 - main port 94
- Specifications 222
- Status viewer 145
- System info 50
- Table showing pin assignment of power supply connector 28
- Technical features 222
- Text entry tool 47
- Troubleshooting 216
- Typical layouts 192
- UL listing ix
- Update firmware 151
- User interface basics 47
- Utilities 148
- Versions 2
- Warning labels viii
- Warning or caution vii
- Website vi
- Wiring
 - protective grounding 29
 - rotation encoder 35