

Original operating instructions

DCR 108i Stationary 2D-code reader



© 2026

Leuze electronic GmbH + Co. KG

In der Braike 1

73277 Owen / Germany

Phone: +49 7021 573-0

Fax: +49 7021 573-199

www.leuze.com



info@leuze.com

1	About this document	5
2	Safety	6
2.1	Intended use	6
2.2	Forseeable misuse.....	6
2.3	Competent persons.....	7
2.4	Disclaimer	7
3	Device description	8
3.1	Device overview	8
3.2	Performance characteristics	8
3.3	Accessories.....	8
3.4	Device construction.....	9
3.5	Indicators and operational controls	9
4	Functions	11
4.1	Camera operating modes	11
4.2	Reference code comparison	11
4.3	Ident Studio V2	11
5	Mounting.....	12
5.1	Determining the mounting position of the code.....	12
5.1.1	Selecting a mounting location.....	12
5.1.2	Avoiding total reflection	12
5.1.3	Reading distance.....	13
5.1.4	Field of view.....	14
5.2	Mounting the code reader	15
5.2.1	Mounting with M3 fastening screws.....	15
5.2.2	Mounting with the BT DCR 100 mounting bracket	15
6	Electrical connection.....	16
6.1	Overview	16
6.1.1	Single connector type	16
6.1.2	Dual connectors type.....	19
6.2	Ethernet star topology	23
6.3	Cable lengths and shielding.....	24
7	Starting up the device – Basic configuration.....	25
7.1	Measures to be performed prior to the initial commissioning.....	25
7.2	Starting the device	25
7.3	Setting the communication parameters	25
7.3.1	Manually setting the IP address	26
7.3.2	Automatically setting the IP address	26
7.3.3	Ethernet host communication	26
7.3.4	RS 232 communication	27
7.4	Configuration via configuration codes.....	27
7.5	Performing further settings.....	27
7.5.1	Optimizing reading performance	27
8	Starting up the device – Ident Studio V2 tool.....	28
8.1	System requirements	28
8.2	Start Ident Studio V2 tool	28
8.3	Short description of the Ident Studio V2 tool.....	29



8.3.1	Menu options of the Ident Studio V2 tool	29
8.3.2	Device configuration mode	30
9	Interfaces – Communication	31
9.1	Configuration command architecture	31
9.2	Supported commands	32
9.2.1	Symbology	32
9.2.2	Decoder and general decoding parameters	48
9.2.3	Scan operation	50
9.2.4	Acknowledgements	50
9.2.5	Communication and output.....	51
9.2.6	General information on the device.....	51
9.2.7	Device configuration	51
9.3	Modbus TCP	53
10	Care, maintenance and disposal	54
11	Diagnostics and troubleshooting	55
12	Service and support	56
13	Technical data	57
13.1	Optical data	57
13.2	Code specifications	57
13.3	General specifications.....	58
13.4	Dimensioned drawing	59
14	Order guide and accessories.....	60
14.1	Nomenclature.....	60
14.2	Type overview	60
14.3	Cables accessories	61
14.4	Other accessories	61
15	Declaration of Conformity.....	62
16	Appendix.....	63
16.1	ASCII character set.....	63
16.2	Code samples	66
16.3	Configuration via configuration codes.....	68
16.4	License terms.....	68

1 About this document

Tab. 1.1: Warning symbols and signal words

	Symbol indicating dangers to persons
	Symbol indicating possible property damage
NOTICE	Signal word for property damage Indicates dangers that may result in property damage if the measures for danger avoidance are not followed.
CAUTION	Signal word for minor injuries Indicates dangers that may result in minor injury if the measures for danger avoidance are not followed.

Tab. 1.2: Other symbols

	Symbol for tips Text passages with this symbol provide you with further information.
	Symbol for action steps Text passages with this symbol instruct you to perform actions.
	Symbol for action results Text passages with this symbol describe the result of the preceding action.

Tab. 1.3: Terms and abbreviations

CMOS	Semiconductor process for implementing integrated circuits (C omplementary M etal- O xide- S emiconductor)
DCR	Camera-based code reader (D ual C ode R eader)
DHCP	Network configuration protocol (D ynamic H ost C onfiguration P rotocol)
DPM code	Code directly applied on a part, not with a label (D irect P art M arking)
EN	European standard
FE	Functional earth
FOV	Reading field of the code reader (F ield o f V iew)
IO or I/O	I nput/ O utput
IP address	Network address, which is based on the Internet Protocol (IP)
LED	LED (L ight E mitting D iode)
MAC address	Hardware address of a device in the network (M edia A ccess C ontrol address)
ROI	Region of interest of the code reader (R egion o f I nterest)
TCP/IP	Internet protocol family (T ransmission C ontrol P rotocol/ I nternet P rotocol)
UDP	Network transmission protocol (U ser D atagram P rotocol)

2 Safety

This code reader was developed, manufactured and tested in accordance with the applicable safety standards. It corresponds to the state of the art.



2.1 Intended use

The code readers of the DCR 100i series are camera-based code readers for all commonly used bar codes, stacked codes and Data Matrix codes.

Areas of application

The code readers of the DCR 100i series are especially designed for the following areas of application:

- Secondary packaging systems
- Electronics industry

 CAUTION	
	<p>Observe intended use!</p> <p>The protection of personnel and the device cannot be guaranteed if the device is operated in a manner not complying with its intended use.</p> <ul style="list-style-type: none"> ↳ Only operate the device in accordance with its intended use. ↳ Leuze electronic GmbH + Co. KG is not liable for damages caused by improper use. ↳ Read these operating instructions before commissioning the device. Knowledge of the operating instructions is an element of proper use.

NOTICE	
	<p>Integrated illumination!</p> <p>The code readers of the DCR 100i series correspond to the following classification with respect to the integrated illumination:</p> <ul style="list-style-type: none"> ↳ Red illumination: Exempt group in acc. with EN 62471

NOTICE	
	<p>Comply with conditions and regulations!</p> <ul style="list-style-type: none"> ↳ Observe the locally applicable legal regulations and the rules of the employer's liability insurance association.

2.2 Forseeable misuse

Any use other than that defined under "Intended use" or which goes beyond that use is considered improper use.

In particular, use of the device is not permitted in the following cases:

- in rooms with explosive atmospheres
- in circuits which are relevant to safety
- in food processing
- for medical purposes

NOTICE	
	<p>Do not modify or otherwise interfere with the device!</p> <ul style="list-style-type: none"> ↳ Do not carry out modifications or otherwise interfere with the device. The device must not be tampered with and must not be changed in any way. ↳ The device's housing must not be opened. ↳ There are no user-serviceable parts inside the device. ↳ Repairs must only be performed by Leuze electronic GmbH + Co. KG.

2.3 Competent persons

Connection, mounting, commissioning and adjustment of the device must only be carried out by competent persons.

Prerequisites for competent persons:

- They have a suitable technical education.
- They are familiar with the rules and regulations for occupational safety and safety at work.
- They are familiar with the operating instructions for the device.
- They have been instructed by the responsible person on the mounting and operation of the device.

Certified electricians

Electrical work must be carried out by a certified electrician.

Due to their technical training, knowledge and experience as well as their familiarity with relevant standards and regulations, certified electricians are able to perform work on electrical systems and independently detect possible dangers.

In Germany, certified electricians must fulfill the requirements of accident-prevention regulations DGUV (German Social Accident Insurance) provision 3 (e.g. electrician foreman). In other countries, there are respective regulations that must be observed.

2.4 Disclaimer

Leuze electronic GmbH + Co. KG is not liable in the following cases:

- The device is not being used properly.
- Reasonably foreseeable misuse is not taken into account.
- Mounting and electrical connection are not properly performed.
- Changes (e.g., constructional) are made to the device.

3 Device description

3.1 Device overview

The code readers of the DCR 100i series are camera-based code readers for all commonly used bar codes, stacked codes, Data Matrix codes and DPM codes (e.g. Code 39/128, EAN 8/13, QR etc.).

The extensive options for device configuration via trigger buttons, configuration codes or software enable adaptation to a multitude of reading tasks.

Code readers of the DCR 100i series perform numerous tasks in industrial code reading such as:

- Omnidirectional code reading
- Reading of codes while at a standstill or in motion
- Multiple code reading
- In secondary packaging machines
- In automatic handling and testing machines

The DCR 1xxi code readers are operated as a "stand-alone" single device with individual IP address. Information on technical data and characteristics: see chapter 13 "Technical data".

3.2 Performance characteristics

NOTICE



Failure to read an F-grade code does not imply that the code reader is faulty or underperforming.

Do **not** use F-grade codes for acceptance testing and operation. Make sure that barcodes are printed in compliance with the relevant ISO or industry quality standard.

- Decoding of 1D-, stacked code, 2D-codes and DPM codes
- Manually adjustable focus for flexible working distance within the reading field
- Maximum depth of field and reading distance of approx. 40 mm ... 550 mm
- Reference code comparison
- Integrated process interfaces RS 232, Ethernet TCP/IP and Modbus TCP.
- 1 switching input
- 2 switching outputs
- Integrated red LED illumination
- Green feedback LED for direct acknowledgment of whether the read process was successful
- A trigger button for intuitive operation without PC
- Industrial design: degree of protection IP64
- Mounting with threads on bottom surfaces
- Variously coded M12 connections for unique assignment of the connections
- Integrated teach functions for automatic adjustment of the exposure and gain

3.3 Accessories

Special accessories are available for the code reader (see chapter 14 "Order guide and accessories").

3.4 Device construction

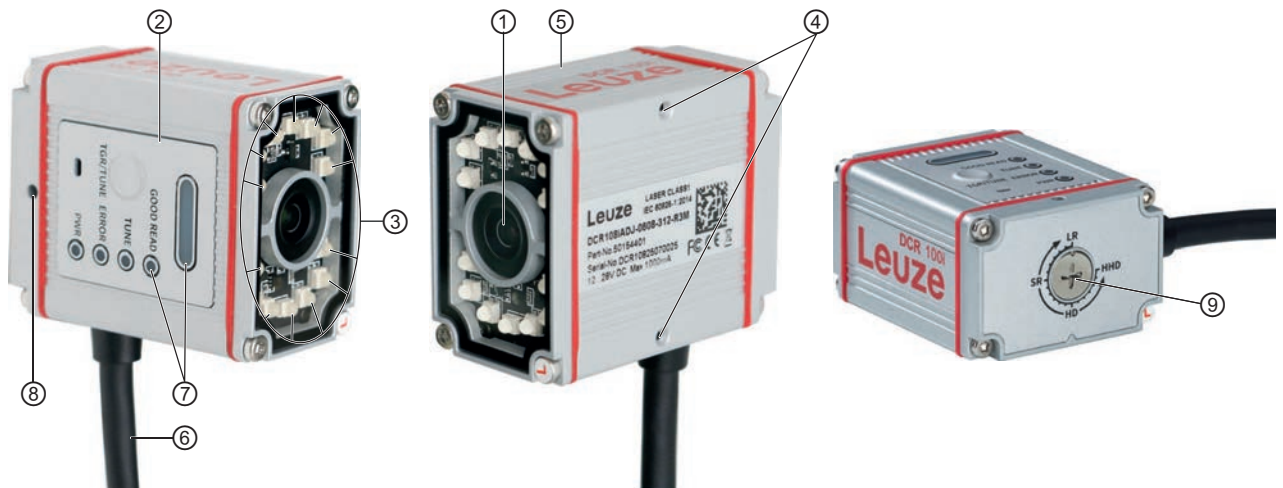

- 1 Lens
- 2 Control panel with indicator LEDs, control buttons
- 3 LEDs for illumination (red)
- 4 M3 mounting thread
- 5 Device housing
- 6 Connection technology
- 7 Feedback LED (green)
- 8 Locking screw for focus adjustment (1.27 mm Hex)
- 9 Screw for focus adjustment

Fig. 3.1: Device construction

3.5 Indicators and operational controls

The device is equipped with the following indicators and operational controls:

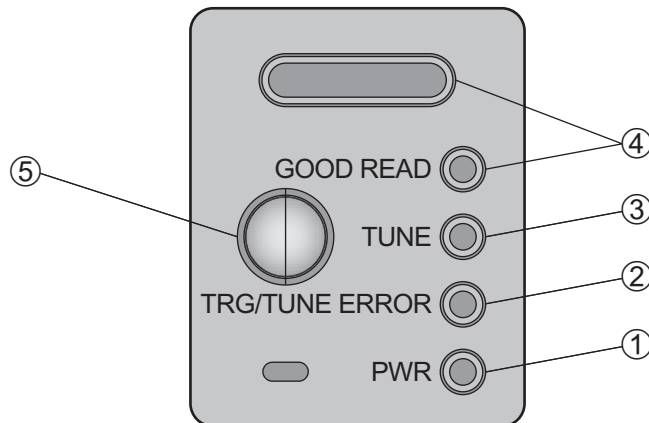

- | | | | |
|---|-----------|------------------------------|---|
| 1 | PWR | LED indicator POWER | Indicates Power ON/OFF and hardware errors. |
| 2 | ERROR | Feedback LED ERROR (no read) | Indicates whether a read was unsuccessful. |
| 3 | TUNE | LED indicator TUNE | Indicates the code reader in tuning mode. |
| 4 | GOOD READ | Feedback LED GOOD READ | Indicates whether a read was successful. |
| 5 | TRG/TUNE | Trigger button | Control button |

Fig. 3.2: Layout of indicator and control panel

PWR LED

Tab. 3.1: Status of PWR LED

Color	Status	Description
Orange	OFF	<ul style="list-style-type: none"> • Device off • No supply voltage
	ON (continuous light)	Device ok, code reading possible

ERROR LED

Tab. 3.2: Status of ERROR LED

Color	Status	Description
Red	Flashing	Reading unsuccessful
	ON (continuous light)	<ul style="list-style-type: none"> • Device error • Tuning unsuccessful

TUNE LED

Tab. 3.3: Status of TUNE LED

Color	Status	Description
Blue	Flashing	Device in tuning mode

GOOD READ LED

Tab. 3.4: Status of GOOD READ LED

Color	Status	Description
Green	ON (continuous light)	Reading successful

Trigger button

Tab. 3.5: Functions of trigger button

Function	Description	Action
Manual trigger	Start code reading in trigger mode	Press the trigger button once.
Enter tuning mode	Enable tuning mode	Press and hold the trigger button more than 3 seconds.
Restore to factory default settings	Restore the device to factory default settings	Press and hold the trigger button more than 15 seconds.

4 Functions

Functions of the code reader:

- Camera operating modes
- Reference code comparison
- Configuration tool Ident Studio V2

4.1 Camera operating modes

The camera operating mode defines how the code reader starts a read process and decodes the code if a code is located in the read field.

Trigger mode

In the "Trigger mode", the code reader captures one image and attempts to decode it. Under uniform conditions, this camera operating mode makes fast decoding possible.

Image sense mode

In the "Presentation mode", the code reader is in the idle state.

In the event of a change in the image area, e.g., by holding up a code, the code reader captures images with illumination (as previously configured) until a code is read successfully. The code reader then switches back to the "wait mode" and the illumination switches off after a few seconds.

Reading the same code multiple times

To prevent the same code from being read and output repeatedly in the "Presentation mode", a delay time can be defined that must elapse before a code can be read again.

The delay time is set or deactivated with the configuration tool Ident Studio V2.

Continuous read mode

In the "Continuous mode", the code reader operates continuously in process mode. In this mode, image acquisition is started again immediately after an image has been processed. An external trigger signal is not required.

NOTICE



For optimum heat dissipation, the sensor should be mounted on metal bracket and use low or medium illumination.

4.2 Reference code comparison

With the reference code comparison, the code reader compares the actual decoding result with a stored reference code – the exact code content is compared.

Set the options for teaching-in a new reference code in the configuration tool Ident Studio V2 under **Settings > Barcode comparison**.

4.3 Ident Studio V2

The configuration tool Ident Studio V2 offers a graphical user interface for the configuration of the code reader via a PC. It can be used to easily configure the code reader in just a few steps (see chapter 8 "Starting up the device – Ident Studio V2 tool").

5 Mounting

The code reader can be mounted in the following ways:

- Mounting using two M3 mounting threads on the bottom of the device
- Mounting on the BT DCR 100 mounting bracket

5.1 Determining the mounting position of the code

5.1.1 Selecting a mounting location

NOTICE	
	The size of the code module influences the maximum reading distance and the width of the reading field. Therefore, when selecting a mounting location and/or the suitable code label, take into account the different reading characteristics of the code reader with various code modules.

NOTICE	
	<p>Observe when choosing the mounting location!</p> <ul style="list-style-type: none"> ↳ Make certain that the required environmental conditions (humidity, temperature) are maintained. ↳ Avoid possible soiling of the reading window due to liquids, abrasion by boxes, or packaging material residues. ↳ Ensure the lowest possible chance of damage to the code reader through mechanical collision or jammed parts. ↳ Avoid possible ambient light influence (no direct sunlight).

Take the following factors into account when selecting the correct mounting location:

- Size, orientation, and position tolerance of the bar codes or Data Matrix codes on the objects to be scanned.
- The reading distance resulting from the code size and code type.
- Time of data output.
Position the device in such a way that, taking into consideration the time required for data processing and the conveyor belt speed, there is sufficient time to e.g. initiate sorting operations on the basis of the read data.
- The permissible line lengths between code reader and host system depending on which interface is used.
- Visibility of the control panel and access to the trigger buttons and focus adjustment.
- No direct sunlight and/or no strong ambient light on the code that is to be read.

Observe the following criteria for the best read results:

- The reading distance is located in the middle part of the read field.
- There is no direct sunlight and protect against ambient light effects.
- The code labels are of good print quality and have good contrast ratios.
- Do not use glossy labels.
- The bar code or Data Matrix code is moved past the reading window with a tilt angle or angle of inclination of 10° ... 20°.

5.1.2 Avoiding total reflection

If the illumination light of the code reader is directly incident on the surface of the code at an angle of 90°, total reflection occurs. The illumination light directly reflected by the code label may overload the code reader and thereby result in non-reading of the code.

- ↳ Mount the code reader with a recommended tilt angle or angle of inclination of $\pm 10^\circ \dots 20^\circ$ from vertical.

5.1.3 Reading distance

In general, the reading field of the code reader becomes larger with increasing reading distance. This also results in a decrease in the resolution.

The following graphics show typical reading distances for the individual optics models of the code reader.

NOTICE

 Code reading while in motion is dependent on the code type, code size, cell or modulus size of the code and the position of the code in the reading field of the code reader.

NOTICE

 Please note that the actual reading distances are also influenced by factors such as labeling material, printing quality, reading angle, printing contrast etc., and may thus deviate from the reading distances specified here.

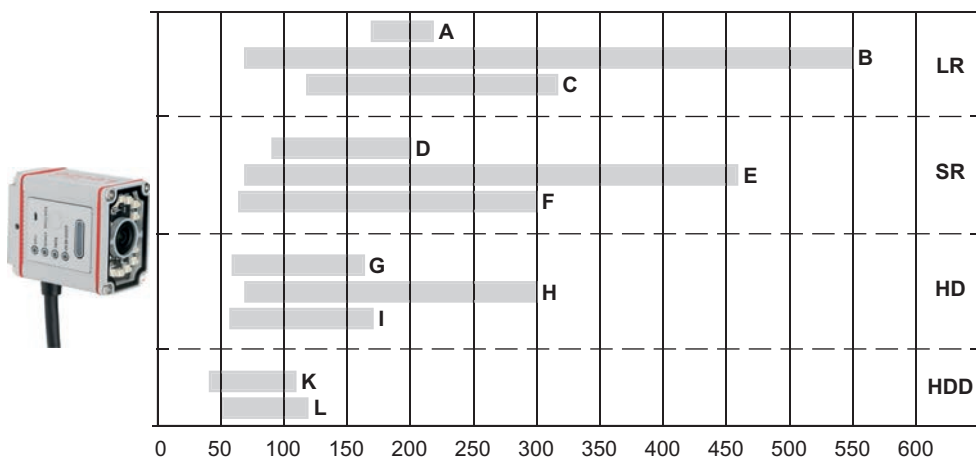

A	0.254 mm (10 mil) / 2D codes	LR	Long range
B	0.33 mm (13 mil) / 1D codes		
C	0.127 mm (5 mil) / 1D codes		
D	0.18 mm (7 mil) / 2D codes	SR	Standard range
E	0.33 mm (13 mil) / 1D codes		
F	0.127 mm (5 mil) / 1D codes		
G	0.18 mm (7 mil) / 2D codes	HD	High density
H	0.33 mm (13 mil) / 1D codes		
I	0.08 mm (3 mil) / 1D codes		
K	0.18 mm (7 mil) / 2D codes	HDD	Hyper high density
L	0.08 mm (3 mil) / 1D codes		

Fig. 5.1: Typical reading distances

Adjusting the focus

Adjust the focus mode to achieve optimal image clarity.

- ↺ Release the locking screw (2).
- ↺ Adjust the focus with the adjustment screw (1) using a screwdriver.
- ↺ Once the desired focus is set, tighten the locking screw (2) using a 1.27 mm hex wrench. The maximum tightening torque is 0.05 Nm.



- 1 Screw for focus adjustment
- 2 Locking screw for focus adjustment

Fig. 5.2: Adjusting the focus

NOTICE	
	<p>Risk of property damage due to improper adjustment!</p> <p>Improper adjustment might result in damage of the screws or the focus mechanism.</p> <ul style="list-style-type: none"> ↳ Make sure the locking screw is released before adjusting the focus to prevent damage to the focus mechanism. ↳ Do not apply excessive force to the adjustment screw when it reaches its mechanical limit, as this may damage the screw or the mechanism.

5.1.4 Field of view

The following table shows the relationship between the working distance and the resulting field of view for the optics models of the sensor. The working distance is the path from the front edge of the sensor to the code. Use the data to calculate the typical field of view (FOV) for your application.

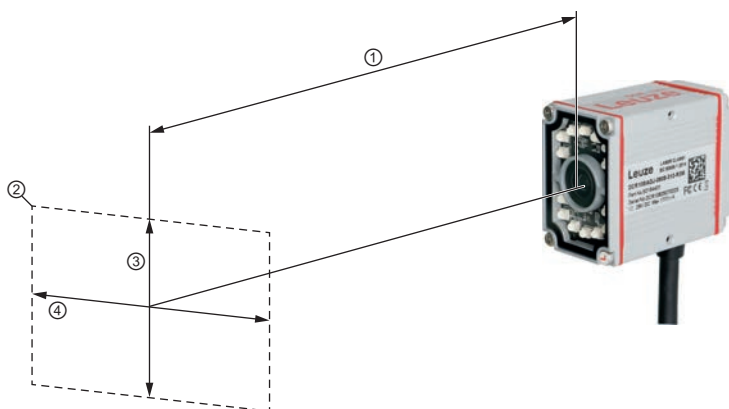

- 1 Code reader distance [mm]
- 2 Reading field
- 3 Reading field height [mm]
- 4 Reading field width [mm]

Fig. 5.3: Field of view

Tab. 5.1: Typical field of view size

Code reader distance [mm]	Reading field height [mm]	Reading field width [mm]
100	52	61
200	103	122
300	155	183
400	206	244
500	257	306

5.2 Mounting the code reader

5.2.1 Mounting with M3 fastening screws

- ↳ Mount the device on the system with M3 fastening screws (not included in scope of delivery).
Max. tightening torque of the fastening screws: 0.6 Nm





5.2.2 Mounting with the BT DCR 100 mounting bracket

Mounting with a BT DCR 100 mounting bracket is intended for wall mounting.

- ↳ Mount the device to the mounting bracket with M3 fastening screws (not included in the scope of delivery).
Max. tightening torque of the fastening screws: 0.6 Nm

Location and thread depth of the mounting thread: see chapter 13.4 "Dimensioned drawing".

6 Electrical connection

⚠ CAUTION	
	<p>Safety notices!</p> <ul style="list-style-type: none"> ↪ Before connecting the device, be sure that the supply voltage agrees with the value printed on the name plate. ↪ Only allow competent persons to perform the electrical connection. ↪ Make sure that the functional earth (FE) is connected correctly. Fault-free operation is only guaranteed if the functional earth is connected properly. ↪ If faults cannot be rectified, take the device out of operation. Protect the device from accidentally being started.
NOTICE	
	<p>Shielding connection!</p> <p>The shielding is connected via the M12 connector housing.</p>
NOTICE	
	<p>Make sure all cable connections are connected strictly according to the specified pinout.</p> <p>Leuze electronic GmbH & Co. KG is not liable for any damage to the product resulting from improper wiring, installation, or use.</p>
NOTICE	
	<p>Ready-made cables are available for all connections.</p>

6.1 Overview

There are two types of connection for DCR 100i series:

- Single connector (DCR1xxiADJ-0608-**3**12-R3M)
- Dual connectors (DCR1xxiADJ-0608-**4**12-R3M)

6.1.1 Single connector type

Connector DCR1xxiADJ-0608-**3**12-R3M

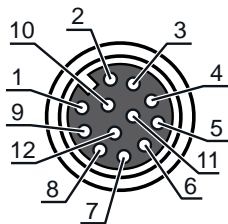

Fig. 6.1: PWR / SWIO / HOST

12-pin M12 female connector (A-coded) for:

- Supply voltage
- Switching inputs/outputs
- RS 232 interface and Ethernet connection

Voltage supply, RS 232 interface, switching inputs/outputs and Ethernet network

The power supply (12 V–28 V DC) is connected via the PWR / SWIO M12 plug.

The RS 232 and Ethernet interfaces share the same M12 cable on the PWR / SWIO / HOST connector.

Tab. 6.1: PWR / SWIO / HOST pin assignment

Pin	Designation	Assignment
1	RS232 TxD	RS 232: TxD signal
2	OUTPUT 1	Digital switching output 1 (No read)
3	SHIELD GND	Functional earth
4	INPUT	Digital switching input 1 (Trigger)
5	OUTPUT 2	Digital switching output 2 (Good read)
6	GND	Negative supply voltage (0 V DC)
7	RS232 RxD	RS 232: RxD signal
8	TX+	TX+ signal
9	TX-	TX- signal
10	V+	+12 ... +28 V DC supply voltage
11	RX-	RX- signal
12	RX+	RX+ signal
Thread (M12 connector)	FE (functional earth)	Connection cable shield. The shield of the connection cable is on the thread of the M12 connector.

NOTICE

This type must be used only with the KY DCR 108 interconnection cable (Part. no. 50154484) recommended in the accessories (see chapter 14.3 "Cables accessories").

NOTICE

Make sure all cable connections are connected strictly according to the specified pinout. Leuze electronic GmbH & Co. KG is not liable for any damage to the product resulting from improper wiring, installation, or use.

Switching input/output

The code reader features three switching inputs/outputs: Input, Output 1 and Output 2

NOTICE

The function of switching input or switching output is set by default and not programmable.

The three switching inputs/outputs are set by default as follows:

- Input
Trigger switching input
- Output 1
NO READ switching output
- Output 2
GOOD READ switching output

Function as switching input (PNP, relay)

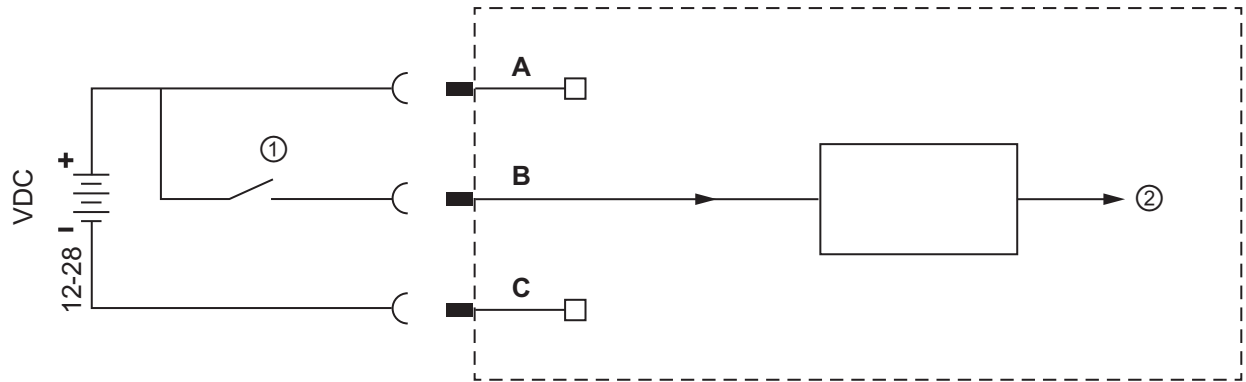

- 1 Switching input max. 15 mA
- 2 Switching input to controller
- A VIN (Red)
- B Trigger (White)
- C GNDIN (Black)

Fig. 6.2: Switching input PNP connection

NOTICE	
	<p>Maximum input current! The input current of the respective switching input is maximum 15 mA.</p>

Function as switching input (NPN)

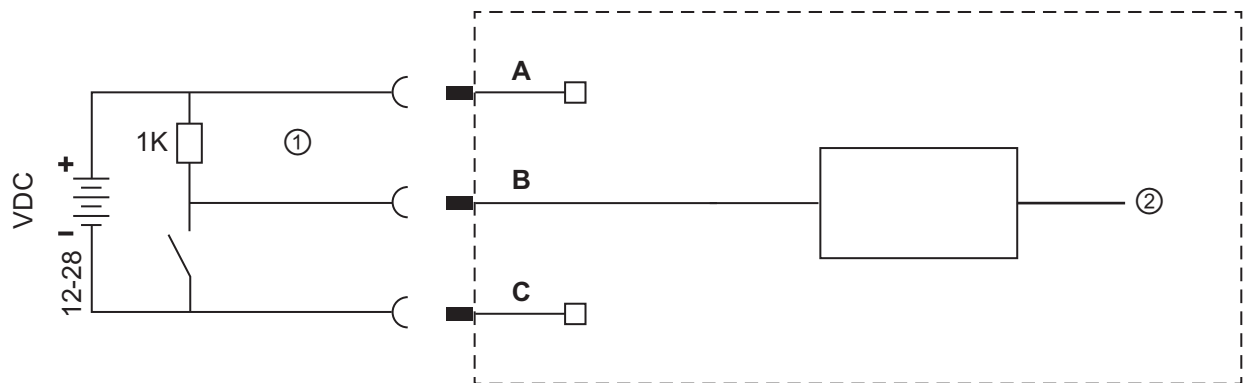

- 1 Switching input max. 10 mA
- 2 Switching input to controller
- A VIN (Red)
- B Trigger (White)
- C GNDIN (Black)

Fig. 6.3: Switching input NPN connection

NOTICE	
	<p>Maximum input current! The input current of the respective switching input is maximum 10 mA.</p>

Function as switching output (NPN)

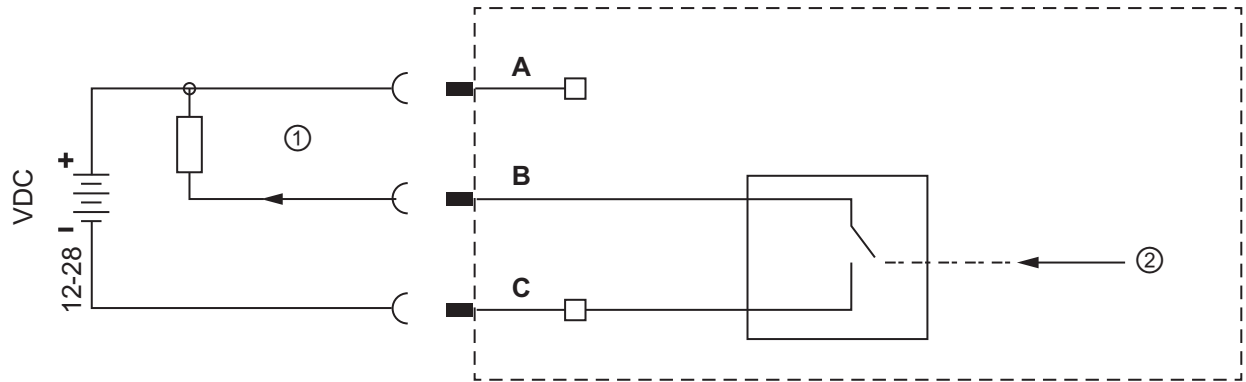

- 1 Switching output max. 50 mA
- 2 Switching output from controller
- A VIN (Red)
- B Good read (Gray) / No read (Brown)
- C GNDIN (Black)

Fig. 6.4: Switching outputs

NOTICE

Maximum loading of the switching outputs!

Do not load the respective switching output of the code reader with more than 50 mA at +12 V ... +28 V DC in normal operation.

Each switching output is not short-circuit proof and not protected against polarity reversal.

6.1.2 Dual connectors type

Dual connectors DCR1xxiADJ-0608-412-R3M

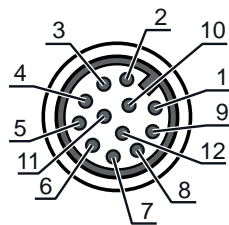

Fig. 6.5: PWR / SWIO

12-pin M12 male connector (A-coded) for:

- Supply voltage
- Switching inputs/outputs
- RS 232 interface

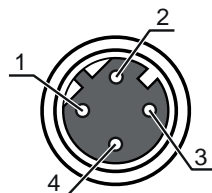

Fig. 6.6: HOST

4-pin M12 female connector (D-coded) for:

- Ethernet connection

Voltage supply, RS 232 interface, switching inputs/outputs

The power supply (12 V–28 V DC) is connected via the PWR / SWIO M12 plug.

The RS 232 interfaces share the same M12 cable on the PWR / SWIO connector.

Tab. 6.2: PWR / SWIO pin assignment

Pin	Designation	Assignment
1	V+	+12 ... +28 V DC supply voltage
2	GND	Negative supply voltage (0 V DC)
3	INPUT	Digital switching input 1 (Trigger)
4	OUTPUT 1	Digital switching output 1 (Good read)
5	SHIELD GND	Functional earth
6	n.c.	Not connected
7	n.c.	Not connected
8	n.c.	Not connected
9	RS232 RxD	RS 232: RxD signal
10	RS232 TxD	RS 232: TxD signal
11	OUTPUT 2	Digital switching output 2 (No read)
12	n.c.	Not connected
Thread (M12 connector)	FE (functional earth)	Connection cable shield. The shield of the connection cable is on the thread of the M12 connector.

NOTICE

Make sure all cable connections are connected strictly according to the specified pinout. Leuze electronic GmbH & Co. KG is not liable for any damage to the product resulting from improper wiring, installation, or use.

Switching input/output

The code reader features three switching inputs/outputs: Input, Output 1 and Output 2

NOTICE

The function of switching input or switching output is set by default and not programmable.

The three switching inputs/outputs are set by default as follows:

- Input
Trigger switching input
- Output 1
GOOD READ switching output
- Output 2
NO READ switching output

Function as switching input (PNP, relay)

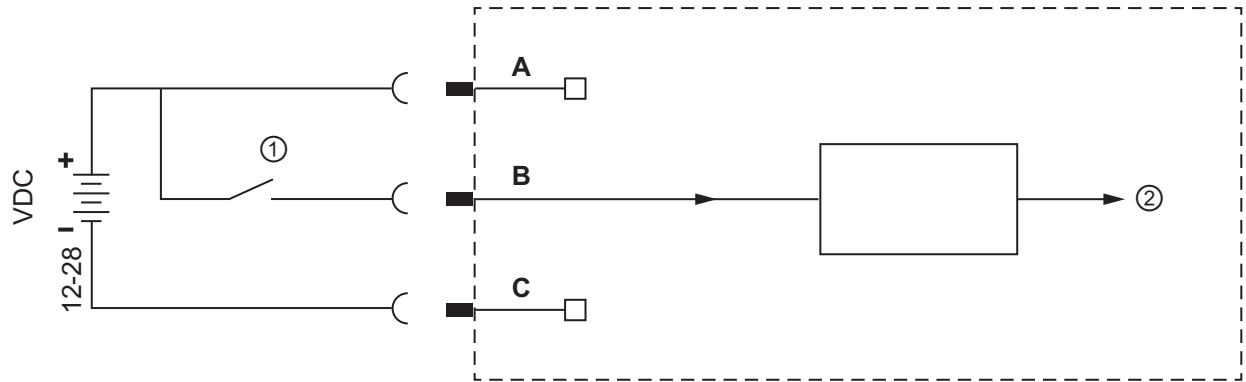

- 1 Switching input max. 15 mA
- 2 Switching input to controller
- A VIN (Brown)
- B Trigger (White)
- C GNDIN (Blue)

Fig. 6.7: Switching input PNP connection

NOTICE	
	<p>Maximum input current! The input current of the respective switching input is maximum 15 mA.</p>

Function as switching input (NPN)

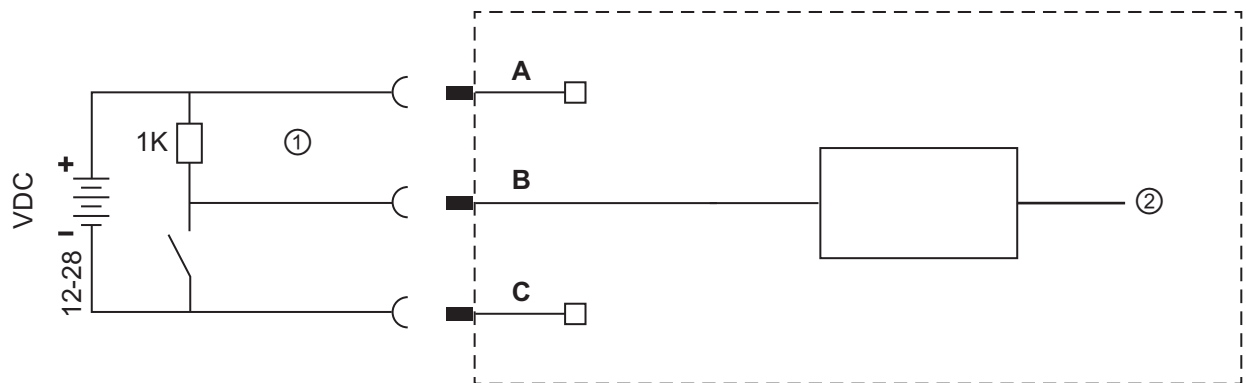

- 1 Switching input max. 10 mA
- 2 Switching input to controller
- A VIN (Brown)
- B Trigger (White)
- C GNDIN (Blue)

Fig. 6.8: Switching input NPN connection

NOTICE	
	<p>Maximum input current! The input current of the respective switching input is maximum 10 mA.</p>

Function as switching output (Output)

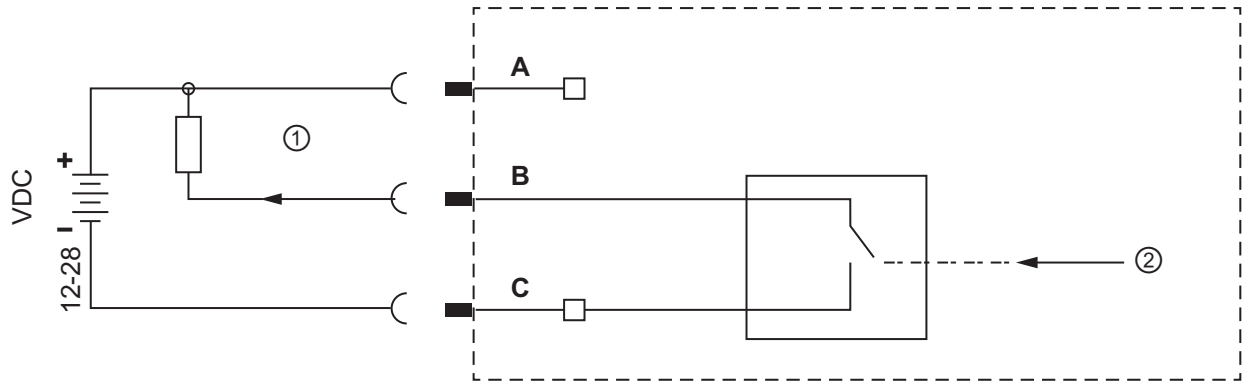

- 1 Switching output max. 50 mA
- 2 Switching output from controller
- A VIN (Brown)
- B Good read (Green) / No read (Gray/pink)
- C GNDIN (Blue)

Fig. 6.9: Switching outputs

NOTICE

Maximum loading of the switching outputs!
 Do not load the respective switching output of the code reader with more than 50 mA at +12 V ... +28 V DC in normal operation.
 Each switching output is not short-circuit proof.

Stand-alone operation in Ethernet network

The code reader is operated as a "stand-alone" single device in an Ethernet star topology with individual IP address. The host interface of the superior system is connected to the HOST M12 socket.

HOST – Host input / Ethernet 4-pin M12 socket (D-coded) for connecting to HOST

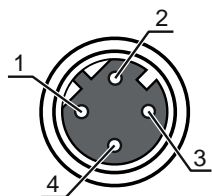

Fig. 6.10: HOST connection

Tab. 6.3: HOST pin assignment

Pin/terminal	Designation	Assignment
1	TD+	Transmit Data +
2	RD+	Receive Data +
3	TD-	Transmit Data -
4	RD-	Receive Data -
Thread (M12 socket)	FE (functional earth)	Connection cable shield. The shield of the connection cable is on the thread of the M12 socket.

NOTICE

Use ready-made cables!
 Ready-made cables are available for all connections (see chapter 14.3 "Cables accessories").

6.2 Ethernet star topology

The code reader is operated as a "stand-alone" single device in an Ethernet star topology with individual IP address.

- The code reader is designed as an Ethernet device with a standard baud rate of 10/100 Mbit.
- A fixed MAC address is assigned to each device by the manufacturer; this address cannot be changed.
- The device automatically supports the transmission rates of 10 Mbit/s (10BASE T) and 100 Mbit/s (10BASE TX), as well as auto-negotiation and auto-crossover.
- The device supports the following protocols and services:
 - TCP/IP (client/server)
 - UDP
 - DHCP
 - PING
- For communication with the superior host system, the corresponding TCP/IP protocol (client/server mode) must be selected.

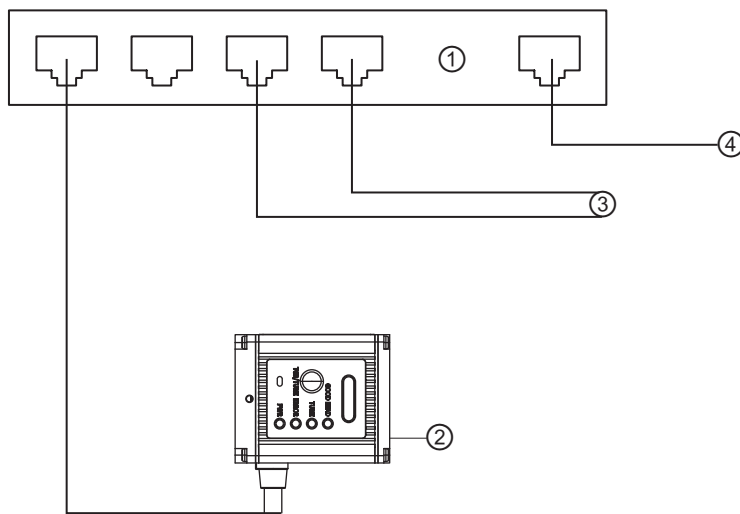

- 1 Ethernet switch
- 2 Code reader of the DCR 100i series
- 3 Other network participants
- 4 Host interface – PC/control

Fig. 6.11: Ethernet star topology

Ethernet cable assignment

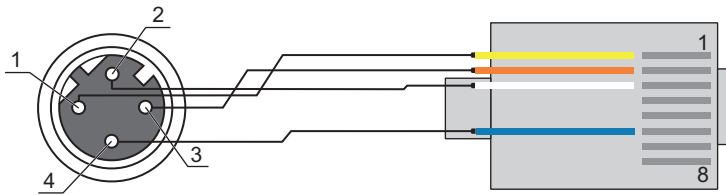

Fig. 6.12: HOST to RJ45 cable assignments
Designed as shielded cable, max. 100 m

Tab. 6.4: Pin to cable assignment RJ45

Pin (M12)	Designation	Pin/core color (RJ45)
1	TD+	1/yellow
2	RD+	3/white
3	TD-	2/orange
4	RD-	6/blue

NOTICE

Self-configured cables with Ethernet interface!

- ⚡ Ensure adequate shielding.
- ⚡ The entire interconnection cable must be shielded and earthed.
- ⚡ The RD+/RD- and TD+/TD- wires must be stranded in pairs.
- ⚡ Use at least a CAT 5 cable for the connection.

6.3 Cable lengths and shielding

Observe the maximum cable lengths and the shielding types:

Connection	Interface	Max. cable length	Shielding
DCR 100i host	RS 232	10 m 1200 m (dependent on baud rate)	Shielding absolutely necessary
Network from the first DCR 100i to the last network participant	Ethernet	Max. segment length: 100 m for 100BASE-TX twisted pair (min. CAT 5)	Shielding absolutely necessary
Switching input		10 m	Not necessary
Switching output		10 m	Not necessary
DCR 100i power supply unit		30 m	Not necessary

7 Starting up the device – Basic configuration

7.1 Measures to be performed prior to the initial commissioning

NOTICE	
	<ul style="list-style-type: none"> ↳ Observe the notices for device arrangement. ↳ If possible, always trigger the code reader with the aid of commands or an external signal transmitter (e.g. photoelectric sensor/diffuse sensor). <ul style="list-style-type: none"> ⇒ Only then can you be certain whether a code has been read (code contents are transmitted) or not (the "NO READ" character is transmitted at the end of the reading gate). ↳ Before commissioning, familiarize yourself with the operation and configuration of the device. ↳ Before connecting the supply voltage, recheck all connections and make sure that they have been properly made.

NOTICE	
	<p>Make sure all cable connections are connected strictly according to the specified pinout.</p> <p>Leuze electronic GmbH & Co. KG is not liable for any damage to the product resulting from improper wiring, installation, or use.</p>

NOTICE	
	<p>Failure to read an F-grade code does not imply that the code reader is faulty or underperforming.</p> <p>Do not use F-grade codes for acceptance testing and operation. Make sure that barcodes are printed in compliance with the relevant ISO or industry quality standard.</p>

7.2 Starting the device

- ↳ Connect the 18 V ... 28 V DC supply voltage.
 - ⇒ After applying the supply voltage, the device operates with the factory settings:
- ↳ Start a reading by pressing the trigger button on the device.
 - ⇒ The integrated illumination becomes visible.

If a code is detected, it is output via the interfaces.

Protocol of the RS 232 interface:

- **<Code data><CR><LF>**
(9600 baud, 8 data bits, no parity, 1 stop bit)

With the factory settings, the device can decode commonly used 1D and 2D code types. Additional code types can be configured as required.

NOTICE	
	<p>Deviations from these settings must be set via the Ident Studio V2 tool.</p>

NOTICE	
	<p>For information on how to proceed in the event of problems during commissioning of the devices see chapter 11 "Diagnostics and troubleshooting".</p> <p>If a problem occurs that cannot be rectified even after checking all electrical connections and settings on the devices and on the host, contact your responsible Leuze subsidiary or Leuze customer service (see chapter 12 "Service and support").</p>

7.3 Setting the communication parameters

With communication parameters, you determine how data is exchanged between device and host system, monitor PCs etc.

7.3.1 Manually setting the IP address



Set the IP address manually if your system does not include a DHCP server or if the IP addresses of the devices are to be set permanently.

Factory settings for the network address of the code readers of the DCR 100i series:

- IP address: 192.168.060.101
- Subnet mask: 255.255.255.0

Setting the IP address with Ident Studio V2

- ↪ Select the option to define the IP address in the Ident Studio V2 tool:
Connection > Local IP > Static IP

NOTICE	
	<p>The device cannot be accessed if the IP address is incorrect!</p> <p>↪ Make sure that the correct IP address is entered. The device can otherwise no longer be accessed.</p>
NOTICE	
	<p>Loss of access!</p> <p>If the IP address is lost or forgotten, the device must be reset to factory settings to regain access.</p> <p>↪ After changing the IP address, record the new IP address.</p>

7.3.2 Automatically setting the IP address

Set the IP address automatically if a DHCP server assigns the IP addresses in the system.

- ↪ Select the option to obtain the IP address automatically in the Ident Studio V2 tool:
Connection > Local IP > DHCP

7.3.3 Ethernet host communication

You can configure the connections to an external host system via the Ethernet host communication.

You can use both the UDP protocol as well as the TCP/IP protocol – in either client or in server mode. Both protocols can be activated simultaneously and used in parallel.

- The connection-free UDP protocol is used primarily to transfer process data to the host (monitor operation).
- The connection-oriented TCP/IP protocol can also be used to transfer commands from the host to the device. With this connection, the data is backed up by the TCP/IP protocol itself.
- If you would like to use the TCP/IP protocol, you must also define whether the device is to operate as a TCP client or as a TCP server.

TCP/IP

- ↪ Activate the TCP/IP protocol.
- ↪ Set the TCP/IP mode of the device.
 - ⇒ In TCP client mode, the device actively establishes the connection to the superior host system, e.g., PC/control as server. The device requires from the user the IP address of the server (host system) and the port number on which the server (host system) accepts a connection. In this case, the device determines when and with whom a connection is established.
 - ⇒ In TCP server mode, the superior host system (PC/control) actively establishes the connection and the connected device waits for the connection to be set up. The TCP/IP stack must be informed by the user as to the local port of the device (port number) on which connection requests from a client application (host system) are to be received. If there is a connection request and a connection is established by the superior host system (PC/control as client), the device – in server mode – accepts the connection. Data can then be sent and received.

- ↳ With a device as TCP client, set the following values:
 - ⇒ IP address of the TCP server, normally the IP address of the control or the host computer
 - ⇒ Port number of the TCP server
 - ⇒ Timeout for the wait time for an answer from the server
 - ⇒ Repetition time for renewed communication attempt following a timeout
- ↳ With a device as TCP server, set the following values:
 - ⇒ Port number for the communication of the device with the TCP clients

The corresponding adjustment options can be found in the Ident Studio V2 tool:
Connection > Protocol

7.3.4 RS 232 communication

The code reader can operate via RS 232 communication if the pins were connected.

The device operates as follows with the factory settings:

- Activation of reading via trigger button. The integrated illumination becomes visible.
- If a code is detected, it is output via the RS 232 interface according to the following protocol.
<Code data><CR><LF>
 (9600 baud, 8 data bits, no parity, 1 stop bit)

7.4 Configuration via configuration codes

You can make configuration changes with the help of printed configuration codes (see chapter 16.3 "Configuration via configuration codes").

7.5 Performing further settings

7.5.1 Optimizing reading performance

Optimize the reading performance of the code reader using the following settings in the Ident Studio V2 tool:

- *Decoding table*
 Limiting of the code types being searched for and the number of digits
 The adjustment options can be found in the Ident Studio V2 tool: **Settings > Barcode**
- *Exposure time*
 A short exposure time enables high object speeds. Because the image brightness is thereby reduced, it may be necessary to adjust the signal gain. Image noise increases as a result, however.
 The adjustment options can be found in the Ident Studio V2 tool: **Image > Exposure**
- *Decoding area*
 Define a region of interest (ROI) to restrict coding to a single part of the image. If no region of interest is defined, the complete image is defined as the region of interest.
 The adjustment options can be found in the Ident Studio V2 tool: **Settings > Scan > Decode area X & Y**
- *Max. decoding time*
 Define the maximum decoding time to limit the execution time of the code search algorithm.
 The adjustment options can be found in the Ident Studio V2 tool: **Settings > Scan > Max. Decode Time**
- *Camera operating mode*
 Select the *Single trigger mode* camera operating mode for fast complete decoding.
 The adjustment options can be found in the Ident Studio V2 tool: **Settings > Scan > Scan mode**

8 Starting up the device – Ident Studio V2 tool

The code readers of the DCR 100i series can be operated and configured via the Ethernet service interface with the integrated Ident Studio V2 tool.

NOTICE	
	The Ident Studio V2 tool is offered in the following languages: English

8.1 System requirements

To use the Ident Studio V2 tool, you need a PC or laptop with the following specifications:

Tab. 8.1: System requirements for the Ident Studio V2 tool

MS Windows	<ul style="list-style-type: none"> • Win 7/8/10/11 (64 bit) • Win 7/8 (32 bit)
------------	--

NOTICE	
	<ul style="list-style-type: none"> ↪ Regularly update the operating system. ↪ Install the current Windows Service Packs.

8.2 Start Ident Studio V2 tool

- ✓ Prerequisite: IP address and subnet mask for the LAN connection with the device are set correctly.
- ↪ Connect the supply voltage to the device.
- ↪ Connect the HOST interface of the device to the PC. The connection to the HOST interface of the device is made via the LAN port of the PC.
- ↪ Start the Ident Studio V2 tool:
192.168.60.101 is the standard Leuze IP address for communication with code readers of the DCR 100i series.

The PC displays the Ident Studio V2 start page with the connected barcode IP address.

NOTICE	
	The process information may be displayed with a time delay depending on the current processing speed.

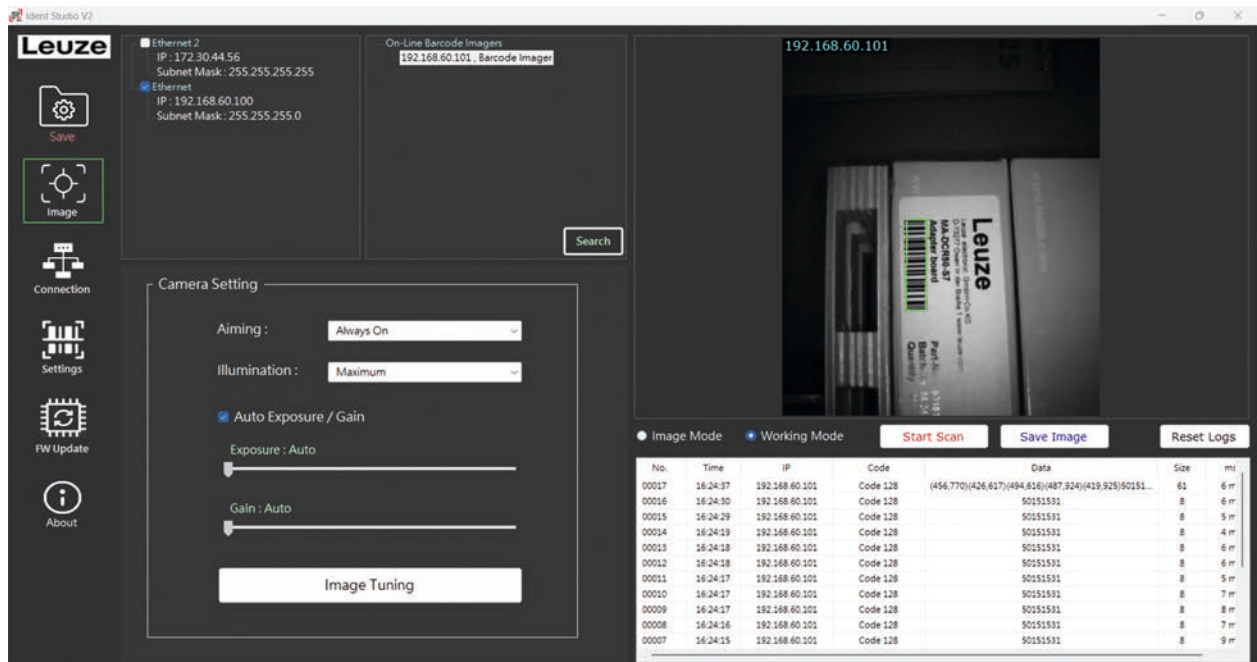



Fig. 8.1: Start page of the Ident Studio V2 tool

8.3 Short description of the Ident Studio V2 tool

The menus and setting tab of the Ident Studio V2 tool are intuitive to operate. The start page of the Ident Studio V2 tool displays the current process information.

NOTICE	
	All configurations should be performed in the Ident Studio V2 tool first. Afterwards, use the hardware interface only to trigger general functions (e.g., "Start Read").

8.3.1 Menu options of the Ident Studio V2 tool

The Ident Studio V2 tool offers the following menu functions:

- **Save**
 - Save current configuration and apply to the code reader
- **Image**
 - Aiming laser
 - Illumination level
 - Illumination LED
 - Exposure and gain adjustment
- **Connection**
 - IP configuration
 - Protocol setting
 - RS 232
- **Settings**
 - Barcode selection
 - Code reading setting
 - Input and output setting
 - Barcode comparison function
- **FW Update**
 - Firmware update

- **About**
 - Information about the software

8.3.2 Device configuration mode

There are two configuration modes in the Ident Studio V2 tool. The mode selector is located at the bottom of the live-view window.

- Working mode
- Image mode

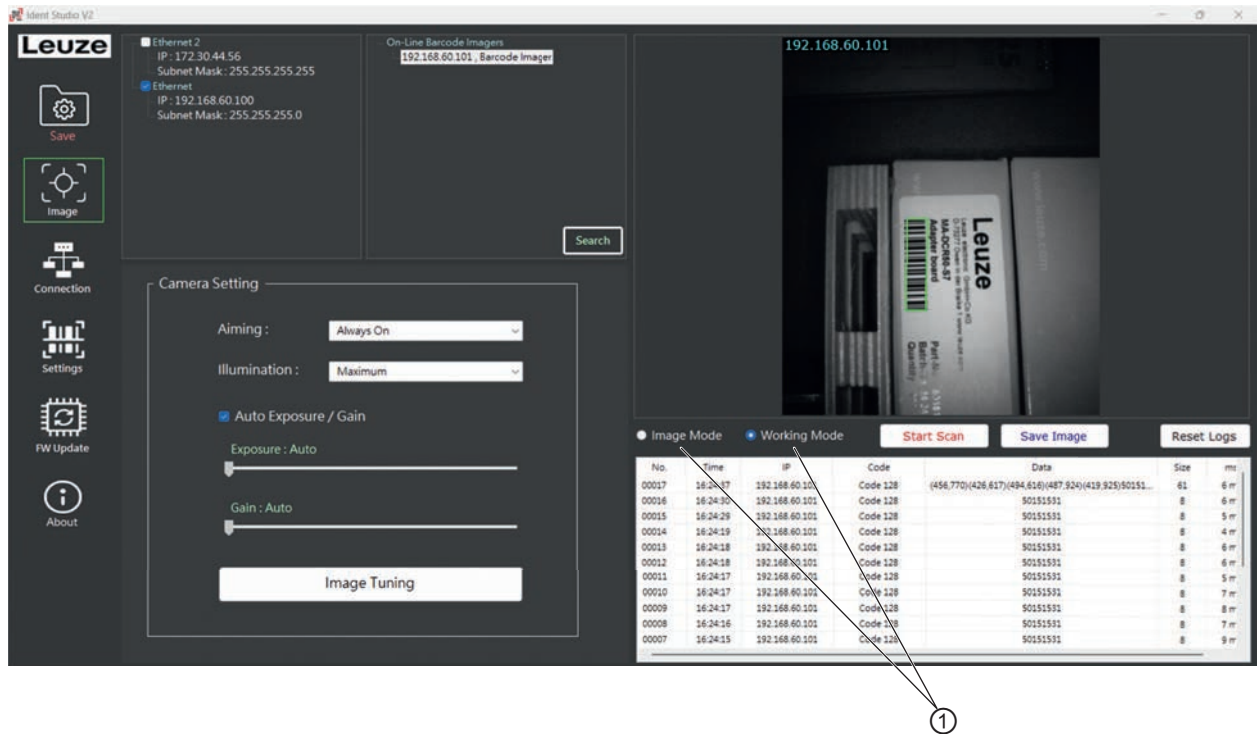

1 Selection of configuration mode

Fig. 8.2: Selection of device configuration mode

Working mode

In working mode, it simulates the device's actual operational behavior. This includes actual trigger events, scan mode under conditions representative of how the reader will be used in actual application.

Image mode

Image mode is optimized for fine-tuning the camera settings – such as exposure, gain, illumination, focus and mounting angle without considering scanning triggers. This mode is ideal for adjusting image parameters before switching to working mode.

9 Interfaces – Communication

Commands can be used to send commands directly to the code reader for control and configuration. The following transmission options are available for the commands:

- Online commands via the RS 232 interface and Ethernet

NOTICE	
	All configurations should be performed in the Ident Studio V2 tool first. Afterwards, use the hardware interface only to trigger general functions (e.g., "Start Read").

9.1 Configuration command architecture

The device only accepts the configuration commands for changing and saving configuration settings in the following format.

Tab. 9.1: Command format

Data length	Transmitting terminal	Identity code	Command	Data	High-byte checksum	Low-byte checksum
1 byte	1 byte	1 byte	1 byte	Max. 32 bytes	1 byte	1 byte

Meaning/content of the command components:

Data length	Without the checksum length <ul style="list-style-type: none"> • Minimum: 5 bytes • Maximum: 36 bytes
Transmitting terminal	<ul style="list-style-type: none"> • 57 (HEX): the end terminal transmits data to the decoding device. • 52 (HEX): the decoding device transmits data to the end terminal.
Identity code	Command identity
Command	Setting / read command
Data	Configuration data
Checksum calculation	$0x10000 - [\text{Data length}] - [\text{Transmitting terminal}] - [\text{Identity code}] - [\text{Command}] - [\text{D1} + \text{D2} + \text{D3} + \dots]$

9.2 Supported commands

9.2.1 Symbology

Tab. 9.2: Symbology

Function		Length (Hex)	Source (Hex)	ExID (Hex)	ExCMD (Hex)	Data (Hex)	High-byte check-sum (Hex)	Low-byte check-sum (Hex)	
		*1 Data length					*2 Refer to checksum calculation		
UPC/EAN add-on codes	Activate	05	57	B0	02	0E	FE	E4	
	Deactivate	05	57	B0	02	0D	FE	E5	
UPC-A	Activate	05	57	B1	01	0E	FE	E4	
	Deactivate	05	57	B1	01	0D	FE	E5	
	Transmit first character	Activate	05	57	B1	02	0E	FE	E3
		Deactivate	05	57	B1	02	0D	FE	E4
	Check	Activate	05	57	B1	03	0E	FE	E2
		Deactivate	05	57	B1	03	0D	FE	E3
	Convert EAN-13	Activate	05	57	B1	04	0E	FE	E1
		Deactivate	05	57	B1	04	0D	FE	E2
	2-digit/5-digit add-on code	Activate	05	57	B1	05	0E	FE	E0
		Deactivate	05	57	B1	05	0D	FE	E1
	Add-on code required	Activate	05	57	B1	06	0E	FE	DF
		Deactivate	05	57	B1	06	0D	FE	E0
	2-digit add-on code	Activate	05	57	B1	07	0E	FE	DE
		Deactivate	05	57	B1	07	0D	FE	DF
	5-digit add-on code	Activate	05	57	B1	08	0E	FE	DD
		Deactivate	05	57	B1	08	0D	FE	DE
Prefix for UPC-A		*1	57	B1	50	1 ... 8 characters	*2	*2	
Suffix for UPC-A		*1	57	B1	53	1 ... 8 characters	*2	*2	

Function		Length (Hex)	Source (Hex)	ExID (Hex)	ExCMD (Hex)	Data (Hex)	High-byte check-sum (Hex)	Low-byte check-sum (Hex)	
		*1 Data length					*2 Refer to checksum calculation		
UPC-E	Activate	05	57	B2	01	0E	FE	E3	
	Deactivate	05	57	B2	01	0D	FE	E4	
	Transmit first character	Activate	05	57	B2	02	0E	FE	E2
		Deactivate	05	57	B2	02	0D	FE	E3
	Check	Activate	05	57	B2	03	0E	FE	E1
		Deactivate	05	57	B2	03	0D	FE	E2
	Convert UPC-A	Activate	05	57	B2	04	0E	FE	E0
		Deactivate	05	57	B2	04	0D	FE	E1
	2-digit/5-digit add-on code	Activate	05	57	B2	05	0E	FE	DF
		Deactivate	05	57	B2	05	0D	FE	E0
	Add-on code required	Activate	05	57	B2	06	0E	FE	DE
		Deactivate	05	57	B2	06	0D	FE	DF
	2-digit add-on code	Activate	05	57	B2	07	0E	FE	DD
		Deactivate	05	57	B2	07	0D	FE	DE
	5-digit add-on code	Activate	05	57	B2	08	0E	FE	DC
		Deactivate	05	57	B2	08	0D	FE	DD
Prefix for UPC-E		*1	57	B2	50	1 ... 8 characters	*2	*2	
Suffix for UPC-E		*1	57	B2	53	1 ... 8 characters	*2	*2	

Function		Length (Hex)	Source (Hex)	ExID (Hex)	ExCMD (Hex)	Data (Hex)	High- byte check- sum (Hex)	Low- byte check- sum (Hex)	
		*1 Data length					*2 Refer to checksum cal- culation		
EAN-8	Activate	05	57	B3	01	0E	FE	E2	
	Deactivate	05	57	B3	01	0D	FE	E3	
	Transmit test data	Activate	05	57	B3	02	0E	FE	E1
		Deactivate	05	57	B3	02	0D	FE	E2
	Convert EAN-13	Activate	05	57	B3	03	0E	FE	E0
		Deactivate	05	57	B3	03	0D	FE	E1
	2-digit/5- digit add- on code	Activate	05	57	B3	04	0E	FE	DF
		Deactivate	05	57	B3	04	0D	FE	E0
	Add-on code re- quired	Activate	05	57	B3	05	0E	FE	DE
		Deactivate	05	57	B3	05	0D	FE	DF
	2-digit add- on code	Activate	05	57	B3	06	0E	FE	DD
		Deactivate	05	57	B3	06	0D	FE	DE
	5-digit add- on code	Activate	05	57	B3	07	0E	FE	DC
		Deactivate	05	57	B3	07	0D	FE	DD
Prefix for EAN-8		*1	57	B3	50	1 ... 8 charac- ters	*2	*2	
Suffix for EAN-8		*1	57	B3	53	1 ... 8 charac- ters	*2	*2	

Function		Length (Hex)	Source (Hex)	ExID (Hex)	ExCMD (Hex)	Data (Hex)	High- byte check- sum (Hex)	Low- byte check- sum (Hex)	
		*1 Data length					*2 Refer to checksum cal- culation		
EAN-13	Activate	05	57	B4	01	0E	FE	E1	
	Deactivate	05	57	B4	01	0D	FE	E2	
	Transmit first char- acter	Activate	05	57	B4	02	0E	FE	E0
		Deactivate	05	57	B4	02	0D	FE	E1
	Convert ISBN	Activate	05	57	B4	03	0E	FE	DF
		Deactivate	05	57	B4	03	0D	FE	E0
	Convert ISSN	Activate	05	57	B4	04	0E	FE	DE
		Deactivate	05	57	B4	04	0D	FE	DF
	2-digit/5- digit add- on code	Activate	05	57	B4	05	0E	FE	DD
		Deactivate	05	57	B4	05	0D	FE	DE
	Add-on code re- quired	Activate	05	57	B4	06	0E	FE	DC
		Deactivate	05	57	B4	06	0D	FE	DD
	2-digit add- on code	Activate	05	57	B4	07	0E	FE	DB
		Deactivate	05	57	B4	07	0D	FE	DC
	5-digit add- on code	Activate	05	57	B4	08	0E	FE	DA
		Deactivate	05	57	B4	08	0D	FE	DB
	Start with 979 und 192 re- quired	Activate	05	57	B4	09	0E	FE	D9
Deactivate		05	57	B4	09	0D	FE	DA	
Prefix for EAN-13		*1	57	B4	50	1 ... 8 charac- ters	*2	*2	
Suffix for EAN-13		*1	57	B4	53	1 ... 8 charac- ters	*2	*2	

Function		Length (Hex)	Source (Hex)	ExID (Hex)	ExCMD (Hex)	Data (Hex)	High-byte check-sum (Hex)	Low-byte check-sum (Hex)	
		*1 Data length					*2 Refer to checksum calculation		
Code 128	Activate	05	57	B5	01	0E	FE	E0	
	Deactivate	05	57	B5	01	0D	FE	E1	
	Read length	Each length	05	57	B5	10	00	FE	DF
		1 discrete length	05	57	B5	11	1 byte of the length	*2	*2
		2 discrete lengths	05	57	B5	12	2 bytes of the length	*2	*2
		Length in the field	05	57	B5	13	2 bytes of the length	*2	*2
	Prefix for Code 128		*1	57	B5	50	1 ... 8 characters	*2	*2
	Suffix for Code 128		*1	57	B5	53	1 ... 8 characters	*2	*2

Function		Length (Hex)	Source (Hex)	ExID (Hex)	ExCMD (Hex)	Data (Hex)	High- byte check- sum (Hex)	Low- byte check- sum (Hex)	
		*1 Data length					*2 Refer to checksum cal- culation		
Code 39	Activate		05	57	B6	01	0E	FE	DF
	Deactivate		05	57	B6	01	0D	FE	E0
	ASCII	Activate	05	57	B6	02	0E	FE	DE
		Deactivate	05	57	B6	02	0D	FE	DF
	Transmit start / end character	Activate	05	57	B6	03	0E	FE	DD
		Deactivate	05	57	B6	03	0D	FE	DE
	Do not check		05	57	B6	04	01	FE	E9
	Check and transmit		05	57	B6	04	02	FE	E8
	Check without transmit- ting		05	57	B6	04	03	FE	E7
	Prefix for Code 39		05	57	B6	50	1 ... 8 charac- ters	*2	*2
	Suffix for Code 39		05	57	B6	53	1 ... 8 charac- ters	*2	*2
	Read length	Each length	05	57	B6	10	00	FE	DE
		1 discrete length	05	57	B6	11	1 byte of the length	*2	*2
		2 discrete lengths	05	57	B6	12	2 bytes of the length	*2	*2
		Length in the field	05	57	B6	13	2 bytes of the length	*2	*2
	Convert to Code 32	Activate	05	57	B8	01	0E	FE	DD
		Deactivate	05	57	B8	01	0D	FE	DE
	Prefix for Code 32		*1	57	B8	50	1 ... 8 charac- ters	*2	*2
	Suffix for Code 32		*1	57	B8	53	1 ... 8 charac- ters	*2	*2

Function		Length (Hex)	Source (Hex)	ExID (Hex)	ExCMD (Hex)	Data (Hex)	High-byte check-sum (Hex)	Low-byte check-sum (Hex)	
		*1 Data length					*2 Refer to checksum calculation		
Code 93	Activate	05	57	B7	01	0E	FE	DE	
	Deactivate	05	57	B7	01	0D	FE	DF	
	Read length	Each length	05	57	B7	10	00	FE	DD
		1 discrete length	05	57	B7	11	1 byte of the length	*2	*2
		2 discrete lengths	06	57	B7	12	2 bytes of the length	*2	*2
		Length in the field	06	57	B7	13	2 bytes of the length	*2	*2
	Prefix for Code 93		*1	57	B7	50	1 ... 8 characters	*2	*2
	Suffix for Code 93		*1	57	B7	53	1 ... 8 characters	*2	*2
Code 32	Activate	05	57	B8	01	0E	FE	DD	
	Deactivate	05	57	B8	01	0D	FE	DE	

Function		Length (Hex)	Source (Hex)	ExID (Hex)	ExCMD (Hex)	Data (Hex)	High- byte check- sum (Hex)	Low- byte check- sum (Hex)	
		*1 Data length					*2 Refer to checksum cal- culation		
Code 11	Activate	05	57	B9	01	0E	FE	DC	
	Deactivate	05	57	B9	01	0D	FE	DD	
	Verify check digit	Deactivate	05	57	B9	02	01	FE	E8
		1 check digit	05	57	B9	02	02	FE	E7
		2 check digits	05	57	B9	02	03	FE	E6
	Transmit check digit	Activate	05	57	B9	03	0E	FE	DA
		Deactivate	05	57	B9	03	0D	FE	DB
	Read length	Each length	05	57	B9	10	00	FE	DB
		1 discrete length	05	57	B9	11	1 byte of the length	*2	*2
		2 discrete lengths	06	57	B9	12	2 bytes of the length	*2	*2
		Length in the field	06	57	B9	13	2 bytes of the length	*2	*2
	Prefix for Code 11		*1	57	B9	50	1 ... 8 characters	*2	*2
	Suffix for Code 11		*1	57	B9	53	1 ... 8 characters	*2	*2

Function		Length (Hex)	Source (Hex)	ExID (Hex)	ExCMD (Hex)	Data (Hex)	High- byte check- sum (Hex)	Low- byte check- sum (Hex)	
		*1 Data length					*2 Refer to checksum cal- culation		
Codabar	Activate	05	57	BA	01	0E	FE	DB	
	Deactivate	05	57	BA	01	0D	FE	DC	
	Do not check	05	57	BA	02	01	FE	E7	
	Check and transmit	05	57	BA	02	02	FE	E6	
	Check without transmit- ting	05	57	BA	02	03	FE	E5	
	Transmit start / end character	Activate	05	57	BA	03	0E	FE	D9
		Deactivate	05	57	BA	03	0D	FE	DA
	Read length	Each length	05	57	BA	10	00	FE	DA
		1 discrete length	05	57	BA	11	1 byte of the length	*2	*2
		2 discrete lengths	06	57	BA	12	2 bytes of the length	*2	*2
		Length in the field	06	57	BA	13	2 bytes of the length	*2	*2
	Prefix for Codabar		*1	57	BA	50	1 ... 8 charac- ters	*2	*2
	Suffix for Codabar		*1	57	BA	53	1 ... 8 charac- ters	*2	*2

Function		Length (Hex)	Source (Hex)	ExID (Hex)	ExCMD (Hex)	Data (Hex)	High-byte check-sum (Hex)	Low-byte check-sum (Hex)	
		*1 Data length					*2 Refer to checksum calculation		
Plessey	Activate	05	57	BB	01	0E	FE	DA	
	Deactivate	05	57	BB	01	0D	FE	DB	
	Read length	Each length	05	57	BB	10	00	FE	D9
		1 discrete length	05	57	BB	11	1 byte of the length	*2	*2
		2 discrete lengths	06	57	BB	12	2 bytes of the length	*2	*2
		Length in the field	06	57	BB	13	2 bytes of the length	*2	*2
	Prefix for Plessey		*1	57	BB	50	1 ... 8 characters	*2	*2
	Suffix for Plessey		*1	57	BB	53	1 ... 8 characters	*2	*2

Function		Length (Hex)	Source (Hex)	ExID (Hex)	ExCMD (Hex)	Data (Hex)	High-byte check-sum (Hex)	Low-byte check-sum (Hex)	
		*1 Data length					*2 Refer to checksum calculation		
MSI Plessey	Activate	05	57	BC	01	0E	FE	D9	
	Deactivate	05	57	BC	01	0D	FE	DA	
	Do not check	05	57	BC	02	01	FE	E5	
	Check Mod 10	05	57	BC	02	02	FE	E4	
	Check Mod 10/10	05	57	BC	02	03	FE	E3	
	Check Mod 11/10	05	57	BC	02	04	FE	E2	
	Transmit test data	Activate	05	57	BC	03	0E	FE	D7
		Deactivate	05	57	BC	03	0D	FE	D8
	Read length	Each length	05	57	BC	10	00	FE	D8
		1 discrete length	05	57	BC	11	1 byte of the length	*2	*2
		2 discrete lengths	06	57	BC	12	2 bytes of the length	*2	*2
		Length in the field	06	57	BC	13	2 bytes of the length	*2	*2
	Prefix for MSI Plessey		*1	57	BC	50	1 ... 8 characters	*2	*2
	Suffix for MSI Plessey		*1	57	BC	53	1 ... 8 characters	*2	*2

Function		Length (Hex)	Source (Hex)	ExID (Hex)	ExCMD (Hex)	Data (Hex)	High-byte check-sum (Hex)	Low-byte check-sum (Hex)	
		*1 Data length					*2 Refer to checksum calculation		
2/5 Inter-leaved	Activate	05	57	BD	01	0E	FE	D8	
	Deactivate	05	57	BD	01	0D	FE	D9	
	Do not check	05	57	BD	02	01	FE	E4	
	Check and transmit	05	57	BD	02	02	FE	E3	
	Check without transmitting	05	57	BD	02	03	FE	E2	
	Read length	Each length	05	57	BD	10	00	FE	D7
		1 discrete length	05	57	BD	11	1 byte of the length	*2	*2
		2 discrete lengths	06	57	BD	12	2 bytes of the length	*2	*2
		Length in the field	06	57	BD	13	2 bytes of the length	*2	*2
		Prefix for 2/5 Inter-leaved	*1	57	BD	50	1 ... 8 characters	*2	*2
	Suffix for 2/5 Inter-leaved	*1	57	BD	53	1 ... 8 characters	*2	*2	
2/5 IATA	Activate	05	57	BE	01	0E	FE	D7	
	Deactivate	05	57	BE	01	0D	FE	D8	
	Prefix for 2/5 IATA	*1	57	BE	50	0E	*2	*2	
	Suffix for 2/5 IATA	*1	57	BE	53	0D	*2	*2	

Function		Length (Hex)	Source (Hex)	ExID (Hex)	ExCMD (Hex)	Data (Hex)	High-byte check-sum (Hex)	Low-byte check-sum (Hex)	
		*1 Data length					*2 Refer to checksum calculation		
2/5 Hong Kong	Activate	05	57	BF	01	0E	FE	D6	
	Deactivate	05	57	BF	01	0D	FE	D7	
	Read length	Each length	05	57	BF	10	00	FE	D5
		1 discrete length	05	57	BF	11	1 byte of the length	*2	*2
		2 discrete lengths	06	57	BF	12	2 bytes of the length	*2	*2
		Length in the field	06	57	BF	13	2 bytes of the length	*2	*2
	Prefix for 2/5 Hong Kong	*1	57	BF	50	1 ... 8 characters	*2	*2	
Suffix for 2/5 Hong Kong	*1	57	BF	53	1 ... 8 characters	*2	*2		
2/5 Straight	Activate	05	57	D0	01	0E	FE	C5	
	Deactivate	05	57	D0	01	0D	FE	C6	
	Prefix for 2/5 Straight	*1	57	D0	50	1 ... 8 characters	*2	*2	
	Suffix for 2/5 Straight	*1	57	D0	53	1 ... 8 characters	*2	*2	
Pharma Code	Activate	05	57	D1	01	0E	FE	C4	
	Deactivate	05	57	D1	01	0D	FE	C5	
	Prefix for Pharma Code	*1	57	D1	50	1 ... 8 characters	*2	*2	
	Suffix for Pharma Code	*1	57	D1	53	1 ... 8 characters	*2	*2	

Function		Length (Hex)	Source (Hex)	ExID (Hex)	ExCMD (Hex)	Data (Hex)	High-byte check-sum (Hex)	Low-byte check-sum (Hex)	
		*1 Data length					*2 Refer to checksum calculation		
GS1 DataBar 14	Activate	05	57	D2	01	0E	FE	C3	
	Deactivate	05	57	D2	01	0D	FE	C4	
	GS1 DataBar 14 Stacked	Activate	05	57	D2	02	0E	FE	C2
		Deactivate	05	57	D2	02	0D	FE	C3
	AI (01) digit	Send	05	57	D2	03	0E	FE	C1
		Do not transmit	05	57	D2	03	0D	FE	C2
Prefix for GS1 DataBar 14	*1	57	D2	50	1 ... 8 characters	*2	*2		
Suffix for GS1 DataBar 14	*1	57	D2	53	1 ... 8 characters	*2	*2		
GS1 DataBar Expanded	Activate	05	57	D3	01	0E	FE	C2	
	Deactivate	05	57	D3	01	0D	FE	C3	
	GS1 DataBar Expanded Stacked	Activate	05	57	D3	02	0E	FE	C1
		Deactivate	05	57	D3	02	0D	FE	C2
	AI (01) digit	Send	05	57	D3	03	0E	FE	C0
		Do not transmit	05	57	D3	03	0D	FE	C1
Prefix for GS1 DataBar Expanded	*1	57	D3	50	1 ... 8 characters	*2	*2		
Suffix for GS1 DataBar Expanded	*1	57	D3	53	1 ... 8 characters	*2	*2		
GS1 DataBar Limited	Activate	05	57	D4	01	0E	FE	C1	
	Deactivate	05	57	D4	01	0D	FE	C2	
	AI (01) digit	Send	05	57	D4	02	0E	FE	C0
		Do not transmit	05	57	D4	02	0D	FE	C1
	Prefix for GS1 DataBar Limited	*1	57	D4	50	1 ... 8 characters	*2	*2	
Suffix for GS1 DataBar Limited	*1	57	D4	53	1 ... 8 characters	*2	*2		

Function		Length (Hex)	Source (Hex)	ExID (Hex)	ExCMD (Hex)	Data (Hex)	High- byte check- sum (Hex)	Low- byte check- sum (Hex)
		*1 Data length					*2 Refer to checksum cal- culation	
CC-A	Activate	05	57	D5	01	0E	FE	C0
	Deactivate	05	57	D5	01	0D	FE	C1
	Prefix for CC-A	*1	57	D5	50	1 ... 8 charac- ters	*2	*2
	Suffix for CC-A	*1	57	D5	53	1 ... 8 charac- ters	*2	*2
CC-B	Activate	05	57	D6	01	0E	FE	BF
	Deactivate	05	57	D6	01	0D	FE	C0
	Prefix for CC-B	*1	57	D6	50	1 ... 8 charac- ters	*2	*2
	Suffix for CC-B	*1	57	D6	53	1 ... 8 charac- ters	*2	*2
CC-C	Activate	05	57	D7	01	0E	FE	BE
	Deactivate	05	57	D7	01	0D	FE	BF
	Prefix for CC-C	*1	57	D7	50	1 ... 8 charac- ters	*2	*2
	Suffix for CC-C	*1	57	D7	53	1 ... 8 charac- ters	*2	*2
PDF417	Activate	05	57	D8	01	0E	FE	BD
	Deactivate	05	57	D8	01	0D	FE	BE
	Prefix for PDF417	*1	57	D8	50	1 ... 8 charac- ters	*2	*2
	Suffix for PDF417	*1	57	D8	53	1 ... 8 charac- ters	*2	*2
Micro PDF417	Activate	05	57	D9	01	0E	FE	BC
	Deactivate	05	57	D9	01	0D	FE	BD
	Prefix for Micro PDF417	*1	57	D9	50	1 ... 8 charac- ters	*2	*2
	Suffix for Micro PDF417	*1	57	D9	53	1 ... 8 charac- ters	*2	*2

Function		Length (Hex)	Source (Hex)	ExID (Hex)	ExCMD (Hex)	Data (Hex)	High- byte check- sum (Hex)	Low- byte check- sum (Hex)	
		*1 Data length					*2 Refer to checksum cal- culation		
Data Matrix	Activate	05	57	DA	01	0E	FE	BB	
	Deactivate	05	57	DA	01	0D	FE	BC	
	Mirror code	Activate	05	57	DA	02	0E	FE	BA
		Deactivate	05	57	DA	02	0D	FE	BB
	Rectangu- lar Data Matrix	Activate	05	57	DA	03	0E	FE	B9
		Deactivate	05	57	DA	03	0D	FE	BA
	Prefix for Data Matrix	*1	57	DA	50	1 ... 8 charac- ters	*2	*2	
Suffix for Data Matrix	*1	57	DA	53	1 ... 8 charac- ters	*2	*2		
QR	Activate	05	57	DB	01	0E	FE	BA	
	Deactivate	05	57	DB	01	0D	FE	BB	
	Mirror code	Activate	05	57	DB	02	0E	FE	B9
		Deactivate	05	57	DB	02	0D	FE	BA
	Prefix for QR	*1	57	DB	50	1 ... 8 charac- ters	*2	*2	
	Suffix for QR	*1	57	DB	53	1 ... 8 charac- ters	*2	*2	
Micro QR	Activate	05	57	DC	01	0E	FE	B9	
	Deactivate	05	57	DC	01	0D	FE	BA	
	Prefix for Micro QR	*1	57	DC	50	1 ... 8 charac- ters	*2	*2	
	Suffix for Micro QR	*1	57	DC	53	1 ... 8 charac- ters	*2	*2	
Aztec	Activate	05	57	DD	01	0E	FE	B8	
	Deactivate	05	57	DD	01	0D	FE	B9	
	Mirror code	Activate	05	57	DD	02	0E	FE	B7
		Deactivate	05	57	DD	02	0D	FE	B8
	Prefix for Aztec	*1	57	DD	50	1 ... 8 charac- ters	*2	*2	
Suffix for Aztec	*1	57	DD	53	1 ... 8 charac- ters	*2	*2		

Function		Length (Hex)	Source (Hex)	ExID (Hex)	ExCMD (Hex)	Data (Hex)	High-byte check-sum (Hex)	Low-byte check-sum (Hex)	
		*1 Data length							*2 Refer to checksum calculation
MaxiCode	Activate	05	57	DE	01	0E	FE	B7	
	Deactivate	05	57	DE	01	0D	FE	B8	
	Mirror code	Activate	05	57	DE	02	0E	FE	B6
		Deactivate	05	57	DE	02	0D	FE	B7
	Prefix for MaxiCode	*1	57	DE	50	1 ... 8 characters	*2	*2	
	Suffix for MaxiCode	*1	57	DE	53	1 ... 8 characters	*2	*2	
Han Xin	Activate	05	57	E0	01	0E	FE	B5	
	Deactivate	05	57	E0	01	0D	FE	B6	
	Prefix for Han Xin	*1	57	E0	50	1 ... 8 characters	*2	*2	
	Suffix for Han Xin	*1	57	E0	53	1 ... 8 characters	*2	*2	

9.2.2 Decoder and general decoding parameters

Tab. 9.3: Decoding parameters

Function		Length (Hex)	Source (Hex)	ExID (Hex)	ExCMD (Hex)	Data (Hex)	High-byte check-sum (Hex)	Low-byte check-sum (Hex)
Activate all symbologies		05	57	B0	01	0E	FE	E5
1D symbologies	Activate	05	57	B0	01	01	FE	F2
	Deactivate	05	57	B0	01	03	FE	F0
2D symbologies	Activate	05	57	B0	01	02	FE	F1
	Deactivate	05	57	B0	01	04	FE	EF
Decoding timeout	Deactivate	05	57	A1	06	00	FE	FD
	5 s	05	57	A1	06	01	FE	FC
	10 s	05	57	A1	06	02	FE	FB
	20 s	05	57	A1	06	03	FE	FA

Function		Length (Hex)	Source (Hex)	ExID (Hex)	ExCMD (Hex)	Data (Hex)	High- byte check- sum (Hex)	Low- byte check- sum (Hex)
Identical code- reading interval	Deactivate	05	57	A1	08	00	FE	FB
	Do not read again	05	57	A1	08	01	FE	FA
	100 ms	05	57	A1	08	02	FE	F9
	200 ms	05	57	A1	08	03	FE	F8
	300 ms	05	57	A1	08	04	FE	F7
	500 ms	05	57	A1	08	05	FE	F6
	1 s	05	57	A1	08	06	FE	F5
	2 s	05	57	A1	08	07	FE	F4
	3 s	05	57	A1	08	08	FE	F3
	4 s	05	57	A1	08	09	FE	F2
5 s	05	57	A1	08	0A	FE	F1	
Decoding redun- dancy	Deactivate	05	57	A1	0B	01	FE	F7
	2x	05	57	A1	0B	02	FE	F6
	3x	05	57	A1	0B	03	FE	F5
Decoding informa- tion	Activate	05	57	A2	01	0E	FE	F3
	Deactivate	05	57	A2	01	0D	FE	F4
Barcode ID	Deactivate	05	57	A2	02	00	FF	00
	AIM ID	05	57	A2	02	01	FE	FF
Final character	None	05	57	A2	03	01	FE	FE
	CR/LF	05	57	A2	03	02	FE	FD
	CR	05	57	A2	03	03	FE	FC
	TAB	05	57	A2	03	04	FE	FB
Prefix (max. 4 characters)	Example = "LEUZ"	08	57	B0	50	4C 45 55 5A	FD	61
	Example = "L"	05	57	B0	50	4C	FE	58
	Deactivate	05	57	B0	50	00	FE	A4
Suffix (max. 4 characters)	Example = "LEUZ"	08	57	B0	53	4C 45 55 5A	FD	5E
	Example = "L"	05	57	B0	53	4C	FE	55
	Deactivate	05	57	B0	53	00	FE	A1

9.2.3 Scan operation

Tab. 9.4: Scan operation

Function		Length (Hex)	Source (Hex)	ExID (Hex)	ExCMD (Hex)	Data (Hex)	High-byte check-sum (Hex)	Low-byte check-sum (Hex)
Scan control	Start scan	05	57	A0	01	01	FF	02
	Stop scan	05	57	A0	01	00	FF	03

9.2.4 Acknowledgements

Tab. 9.5: Acknowledgements

Function		Length (Hex)	Source (Hex)	ExID (Hex)	ExCMD (Hex)	Data (Hex)	High-byte check-sum (Hex)	Low-byte check-sum (Hex)
		*1 Data length					*2 Refer to checksum calculation	
ACK acknowledgement	Activate	05	57	A0	00	01	FF	03
	Deactivate	05	57	A0	00	00	FF	04
Error message	Activate	05	57	A1	0E	01	FE	F4
	Deactivate	05	57	A1	0E	00	FE	F5
	Configure No read message	*1	57	A1	1E	Max. 9 characters	*2	*2
	Example="BAD"	07	57	A1	1E	42 41 44	FE	1C

When a terminal transmits an instruction to a device, the device sends back the following message so that the terminal can determine whether the instruction was successful or failed.

If the command set is **successful**, the decoding device sends the following 5-byte data in hexadecimal (**ACK**) to the end terminal.

52	A0	EC	FE	74
----	----	----	----	----

If the command set **fails**, the decoding device sends the following 5-byte data in hexadecimal (**NAK**) to the end terminal.

52	A0	E0	FE	80
----	----	----	----	----

9.2.5 Communication and output

Tab. 9.6: Communication and output

Function		Length (Hex)	Source (Hex)	ExID (Hex)	ExCMD (Hex)	Data (Hex)	High-byte check-sum (Hex)	Low-byte check-sum (Hex)
Confirm communication status		05	57	0E	0D	01	FF	88
Baud rate	9600	05	57	A1	0C	01	FE	F6
	19200	05	57	A1	0C	02	FE	F5
	38400	05	57	A1	0C	03	FE	F4
	57600	05	57	A1	0C	04	FE	F3
	115200	05	57	A1	0C	05	FE	F2
	230400	05	57	A1	0C	06	FE	F1

9.2.6 General information on the device

Tab. 9.7: General information

Function		Length (Hex)	Source (Hex)	ExID (Hex)	ExCMD (Hex)	Data (Hex)	High-byte check-sum (Hex)	Low-byte check-sum (Hex)
Get firmware information		05	57	0E	0D	02	FF	87
Check scan mode		05	57	0E	0D	03	FF	86
Read scan mode		05	57	0E	0D	04	FF	85
Read decoding results		05	57	0E	0D	05	FF	84

9.2.7 Device configuration

Tab. 9.8: Configuration

Function		Length (Hex)	Source (Hex)	ExID (Hex)	ExCMD (Hex)	Data (Hex)	High-byte check-sum (Hex)	Low-byte check-sum (Hex)
Scan mode	Trigger mode	05	57	A1	02	01	FF	00
	Sensor mode	05	57	A1	02	02	FE	FF
	Continuous mode	05	57	A1	02	03	FE	FE
	Pulse trigger	05	57	A1	02	04	FE	FD
Scan mode sensitivity	Low sensitivity	05	57	A1	0A	01	FE	F8
	Medium sensitivity	05	57	A1	0A	02	FE	F7
	High sensitivity	05	57	A1	0A	03	FE	F6
Target LED	Deactivate	05	57	A1	03	00	FF	00
	Scan on	05	57	A1	03	01	FE	FF
	Always on	05	57	A1	03	02	FE	FE

Function		Length (Hex)	Source (Hex)	ExID (Hex)	ExCMD (Hex)	Data (Hex)	High- byte check- sum (Hex)	Low- byte check- sum (Hex)
Illumination mode	Deactivate	05	57	A1	04	00	FE	FF
	Scan on	05	57	A1	04	01	FE	FE
	Always on	05	57	A1	04	02	FE	FD
	Fade up	05	57	A1	04	03	FE	FC
Illumination level	Minimum	05	57	A1	04	11	FE	EE
	Medium	05	57	A1	04	12	FE	ED
	Maximum	05	57	A1	04	13	FE	EC
Good read buzzer	Activate	05	57	A1	05	0E	FE	F0
	Deactivate	05	57	A1	05	0D	FE	F1
Good read buzzer frequency	800 Hz	05	57	A1	05	21	FE	DD
	1600 Hz	05	57	A1	05	22	FE	DC
	2730 Hz	05	57	A1	05	23	FE	DB
	4200 Hz	05	57	A1	05	24	FE	DA
Save setup		05	57	A0	08	01	FE	FB
Factory reset		05	57	A1	01	0F	FE	F3
Reboot		05	57	A0	08	FF	FD	FD

9.3 Modbus TCP

The code reader supports communication via Modbus TCP, and the table below lists the corresponding register addresses.

Tab. 9.9: Modbus TCP addresses

Function code		Address	Respond
01	Read coil	0000	Read scanning trigger state 1: On 0: Off
05	Write single coil	0000	Scanning trigger control 1: On 0: Off
06	Write single register	0000	Set scan mode 1: Level trigger 2: Image sense 3: Continuous 4: Plus trigger
04	Read input register	0000	Read scan mode 1: Level trigger 2: Image sense 3: Continuous 4: Plus trigger
		0001	Bytes of barcode
03	Read holding register	0000	Data of barcode Note: The bytes of barcode will be reset to 0 after reading the data.

10 Care, maintenance and disposal

Cleaning

Clean the protective screen of the device with a soft cloth before mounting.

NOTICE

**Do not use aggressive cleaning agents!**

Do not use aggressive cleaning agents such as thinner or acetone for cleaning the device.

Maintenance

Usually, the device does not require any maintenance by the operator.

Repairs to the device must only be carried out by the manufacturer.

For repairs, contact your responsible Leuze subsidiary or Leuze customer service (see chapter 12 "Service and support").

Disposing

NOTICE



For disposal observe the applicable national regulations regarding electronic components.

11 Diagnostics and troubleshooting

Error signaling via LED

Tab. 11.1: Meaning of the LED indicators

LED	Error	Possible error cause	Measures
PWR	Off	<ul style="list-style-type: none">• No supply voltage connected to the device• Hardware error	<ul style="list-style-type: none">• Check supply voltage• Contact Leuze customer service
ERROR	Red, continuous light	Device error	Reset the device

12 Service and support

Service hotline

You can find the contact information for the hotline in your country on our website www.leuze.com under **Contact & Support**.

Repair service and returns

Defective devices are repaired in our service centers competently and quickly. We offer you an extensive service packet to keep any system downtimes to a minimum. Our service center requires the following information:

- Your customer number
- Product description or part description
- Serial number or batch number
- Reason for requesting support together with a description

Please register the merchandise concerned. Simply register return of the merchandise on our website www.leuze.com under **Contact & Support > Repair Service & Returns**.

To ensure quick and easy processing of your request, we will send you a returns order with the returns address in digital form.

What to do should servicing be required?

NOTICE	
	<p>Please use this chapter as a master copy should servicing be required!</p> <p>↪ Enter the contact information and fax this form together with your service order to the fax number given below.</p>

Customer data (please complete)

Device type:	
Serial number:	
Firmware:	
Status of LEDs:	
Error description:	
Company:	
Contact person/department:	
Phone (direct dial):	
Fax:	
Street/No:	
ZIP code/City:	
Country:	

Leuze Service fax number:

+49 7021 573 - 199

13 Technical data

13.1 Optical data

Integrated LED illumination	Red light illumination: Exempt group in acc. with EN 62471
Integrated feedback LED	Green
Beam exit	Front
Image sensor	Global shutter CMOS Imager
Camera resolution	1080 x 1280 px

13.2 Code specifications

Code type	2/5 Hong Kong 2/5 IATA 2/5 Interleaved Aztec Codabar Code 32 Code 39 Code 93 Code 128 Composite Codes Data Matrix Code EAN 8/13 GS1 Databar Expanded GS1 Databar Expanded Stacked GS1 Databar Limited GS1 Databar RSS 14 GS1 Databar RSS 14 Stacked Maxicode Micro QR MSI Plessey PDF417 PDF417 Micro Pharma Code QR code UPC-A UPC-E
-----------	--

13.3 General specifications

Tab. 13.1: Electrical equipment

Supply voltage U_B	12 V ... 28 V DC <ul style="list-style-type: none"> • With overload protection • Not short-circuit proof and no reverse-polarity protection
Average power consumption	11 W
Switching input Switching output	12 V ... 28 V DC, depending on supply voltage I_{max} : 50 mA per switching output Not short-circuit proof and no reverse-polarity protection

Process interface	RS 232, Ethernet 10/100 Mbit/s RS 232 default: <ul style="list-style-type: none"> • 9600 Bd, 8 data bits, no parity, 1 stop bit
-------------------	---

Tab. 13.2: Operating and display elements

Button	1 control button
LEDs	1 LED (amber) for power (PWR) 1 LED (green) for Good read 1 LED (red) for error and reading unsuccessful 1 LED (blue) for tuning mode

Tab. 13.3: Mechanical data

Degree of protection	IP64 acc. to EN 60529 With screwed-on M12 connectors or mounted caps
VDE protection class	III (EN 61140)
Connection technology	M12 connectors
Weight	150 g
Dimensions (H x W x D)	44 x 29 x 53 mm
Fastening	2 M3 threaded inserts on the bottom of device, 4 mm deep
Housing	Housing: aluminum
Optics cover	Glass

Tab. 13.4: Environmental data

Ambient temp. (operation/storage)	0 °C ... +50 °C/-30 °C ... +70 °C
Air humidity	max. 95% rel. humidity, non-condensing
Ambient light	Max. 2000 Lux
Electromagnetic compatibility	EN 61000-4-2, EN 61000-4-3, EN 61000-4-8
Conformity	CE, FCC

13.4 Dimensioned drawing

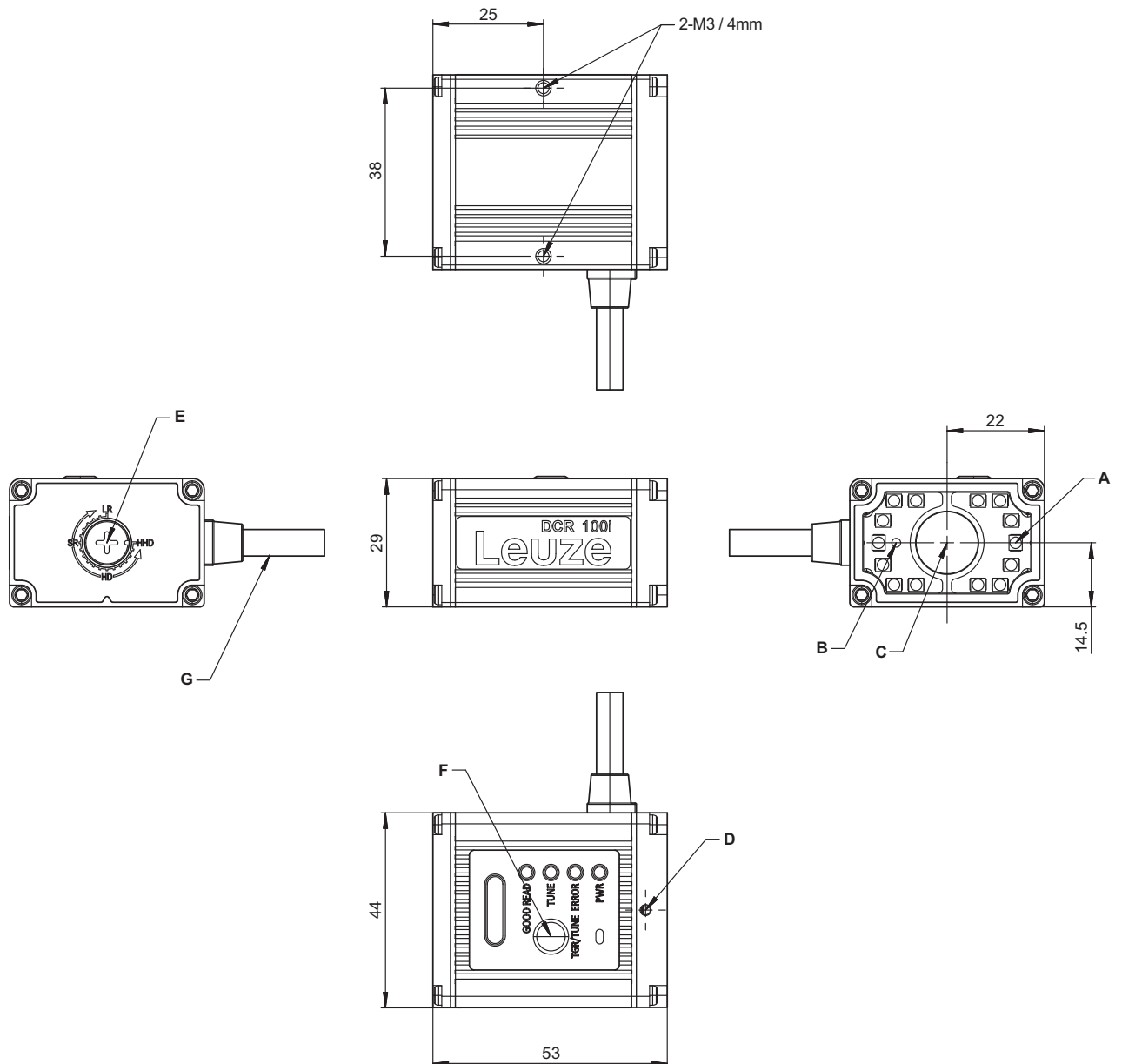

all dimensions in mm

- A Integrated LED for illumination (red light)
- B Integrated target laser diode (red)
- C Center of optical axis
- D Locking screw for focus adjustment (1.27 mm Hex)
- E Screw for focus adjustment
 - LR: Long range
 - SR: Standard range
 - HD: High density
 - HDD: Hyper High density
- F Trigger/Tune button

Fig. 13.1: DCR 100i dimensioned drawing

14 Order guide and accessories

14.1 Nomenclature

Part designation: **DCR 1XXi YYY-ZZZZ-ABC-DEF-GGGG**

Tab. 14.1: Part number code

DCR	Operating principle: Dual Code Reader
1	1: DCR 100 series
XX	Host interface 08: RS 232, Ethernet TCP/IP, ModbusTCP 48: PROFINET-IO, Ethernet TCP/IP, RS 232 58: EtherNet/IP, Ethernet TCP/IP, RS 232
i	Integrated fieldbus technology
YYY	Focus ADJ: Manually adjustable
ZZZZ	Optics model: 0608: Focal length 6 mm and aperture f/8.0
A	Connection 3: Cable with single industrial plug 4: Special cable with dual industrial plug
B	Cable length 1: 0.3 m
C	Beam exit 2: Front side
D	Illumination R: Red
E	Resolution range 3: 1024x768 ... 1280x1024 px
F	Imager type M: Monochrome
GGGG	Special equipment F001: NPN switching output

NOTICE



A list with all available device types can be found on the Leuze website www.leuze.com.

14.2 Type overview

Tab. 14.2: Type overview

Part no.	Designation	Description
50154401	DCR108iADJ-0608-312-R3M-F001	Stationary 2D-code reader (Single connector)
50154402	DCR108iADJ-0608-412-R3M-F001	Stationary 2D-code reader (Dual connectors)

14.3 Cables accessories

Cable for DCR1xxiADJ-0608-312-R3M-XXXX (Single connector type)

Tab. 14.3: Connection cable

Part no.	Designation	Description
50154484	KY DCR 108	Interconnection cable

Cables for DCR1xxiADJ-0608-412-R3M-XXXX (Dual connectors type)

Tab. 14.4: Power connection cables

Part no.	Designation	Description
M12 socket (12-pin, A-coded), axial connector, open cable end, shielded		
50130281	KD S-M12-CA-P1-020	Connection cable, length 2 m
50130282	KD S-M12-CA-P1-050	Connection cable, length 5 m
50130283	KD S-M12-CA-P1-100	Connection cable, length 10 m
50147677	KD S-M12-CA-P1-150-V4A	Connection cable, length 15 m, V4A screw fitting

Tab. 14.5: Ethernet connection cables

Part no.	Designation	Description
M12 plug (4-pin, D-coded), axial connector, open cable end, shielded		
50135073	KS ET-M12-4A-P7-020	Ethernet connection cable, length 2 m
50135074	KS ET-M12-4A-P7-050	Ethernet connection cable, length 5 m
50135075	KS ET-M12-4A-P7-100	Ethernet connection cable, length 10 m
50135076	KS ET-M12-4A-P7-150	Ethernet connection cable, length 15 m
50135077	KS ET-M12-4A-P7-300	Ethernet connection cable, length 30 m
M12 plug (4-pin, D-coded), axial connector to RJ45, shielded		
50135080	KSS ET-M12-4A-RJ45-A-P7-020	Ethernet interconnection cable (on RJ45), length 2 m
50135081	KSS ET-M12-4A-RJ45-A-P7-050	Ethernet interconnection cable (on RJ45), length 5 m
50135082	KSS ET-M12-4A-RJ45-A-P7-100	Ethernet interconnection cable (on RJ45), length 10 m
50135083	KSS ET-M12-4A-RJ45-A-P7-150	Ethernet interconnection cable (on RJ45), length 15 m
50135084	KSS ET-M12-4A-RJ45-A-P7-300	Ethernet interconnection cable (on RJ45), length 30 m

14.4 Other accessories

Tab. 14.6: Mounting systems

Part no.	Designation	Description
50154483	BT DCR 100	Mounting bracket

15 Declaration of Conformity

The code readers of the DCR 100i series have been developed and manufactured in accordance with the applicable European standards and directives.

NOTICE	
	<p>You can download the EC Declaration of Conformity from the Leuze website.</p> <ul style="list-style-type: none">↳ Call up the Leuze website: www.leuze.com.↳ Enter the type designation or part number of the device as the search term. The article number can be found on the name plate of the device under the entry "Part. No."↳ The documents can be found on the product page for the device under the <i>Downloads</i> tab.

16 Appendix

16.1 ASCII character set

ASCII	Dec.	Hex.	Oct.	Designation	Meaning
NUL	0	00	0	ZERO	Zero
SOH	1	01	1	START OF HEADING	Start of heading
STX	2	02	2	START OF TEXT	Start of text characters
ETX	3	03	3	END OF TEXT	Last character of text
EOT	4	04	4	END OF TRANSMISS.	End of transmission
ENQ	5	05	5	ENQUIRY	Request for data trans.
ACK	6	06	6	ACKNOWLEDGE	Positive acknowledgment
BEL	7	07	7	BELL	Bell signal
BS	8	08	10	BACKSPACE	Backspace
HT	9	09	11	HORIZ. TABULATOR	Horizontal tabulator
LF	10	0A	12	LINE FEED	Line feed
VT	11	0B	13	VERT. TABULATOR	Vertical tabulator
FF	12	0C	14	FORM FEED	Form feed
CR	13	0D	15	CARRIAGE RETURN	Carriage return
SO	14	0E	16	SHIFT OUT	Shift out
SI	15	0F	17	SHIFT IN	Shift in
DLE	16	10	20	DATA LINK ESCAPE	Data link escape
DC1	17	11	21	DEVICE CONTROL 1	Device control character 1
DC2	18	12	22	DEVICE CONTROL 2	Device control character 2
DC3	19	13	23	DEVICE CONTROL 3	Device control character 3
DC4	20	14	24	DEVICE CONTROL 4	Device control character 4
NAK	21	15	25	NEG. ACKNOWLEDGE	Negative acknowledge
SYN	22	16	26	SYNCHRONOUS IDLE	Synchronization
ETB	23	17	27	EOF TRANSM. BLOCK	End of data transmission block
CAN	24	18	30	CANCEL	Invalid
EM	25	19	31	END OF MEDIUM	End of medium
SUB	26	1A	32	SUBSTITUTE	Substitution
ESC	27	1B	33	ESCAPE	Escape
FS	28	1C	34	FILE SEPARATOR	File separator
GS	29	1D	35	GROUP SEPARATOR	Group separator
RS	30	1E	36	RECORD SEPARATOR	Record separator
US	31	1F	37	UNIT SEPARATOR	Unit separator
SP	32	20	40	SPACE	Space
!	33	21	41	EXCLAMATION POINT	Exclamation point
"	34	22	42	QUOTATION MARK	Quotation mark
#	35	23	43	NUMBER SIGN	Number sign
\$	36	24	44	DOLLAR SIGN	Dollar sign
%	37	25	45	PERCENT SIGN	Percent sign

ASCII	Dec.	Hex.	Oct.	Designation	Meaning
&	38	26	46	AMPERSAND	Ampersand
'	39	27	47	APOSTROPHE	Apostrophe
(40	28	50	OPEN. PARENTHESIS	Open parenthesis
)	41	29	51	CLOS. PARENTHESIS	Closed parenthesis
*	42	2A	52	ASTERISK	Asterisk
+	43	2B	53	PLUS	Plus sign
,	44	2C	54	COMMA	Comma
-	45	2D	55	HYPHEN (MINUS)	Hyphen
.	46	2E	56	PERIOD (DECIMAL)	Period (decimal)
/	47	2F	57	SLANT	Slant
0	48	30	60	0	Number
1	49	31	61	1	Number
2	50	32	62	2	Number
3	51	33	63	3	Number
4	52	34	64	4	Number
5	53	35	65	5	Number
6	54	36	66	6	Number
7	55	37	67	7	Number
8	56	38	70	8	Number
9	57	39	71	9	Number
:	58	3A	72	COLON	Colon
;	59	3B	73	SEMICOLON	Semicolon
<	60	3C	74	LESS THAN	Less than
=	61	3D	75	EQUALS	Equals
>	62	3E	76	GREATER THAN	Greater than
?	63	3F	77	QUESTION MARK	Question mark
@	64	40	100	COMMERCIAL AT	Commercial AT
A	65	41	101	A	Capital letter
B	66	42	102	B	Capital letter
C	67	43	103	C	Capital letter
D	68	44	104	D	Capital letter
E	69	45	105	E	Capital letter
F	70	46	106	F	Capital letter
G	71	47	107	G	Capital letter
H	72	48	110	H	Capital letter
I	73	49	111	I	Capital letter
J	74	4A	112	J	Capital letter
K	75	4B	113	K	Capital letter
L	76	4C	114	L	Capital letter
M	77	4D	115	M	Capital letter

ASCII	Dec.	Hex.	Oct.	Designation	Meaning
N	78	4E	116	N	Capital letter
O	79	4F	117	O	Capital letter
P	80	50	120	P	Capital letter
Q	81	51	121	Q	Capital letter
R	82	52	122	R	Capital letter
S	83	53	123	S	Capital letter
T	84	54	124	T	Capital letter
U	85	55	125	U	Capital letter
V	86	56	126	V	Capital letter
W	87	57	127	W	Capital letter
X	88	58	130	X	Capital letter
Y	89	59	131	Y	Capital letter
Z	90	5A	132	Z	Capital letter
[91	5B	133	OPENING BRACKET	Opening bracket
\	92	5C	134	REVERSE SLANT	Reverse slant
]	93	5D	135	CLOSING BRACKET	Closing bracket
^	94	5E	136	CIRCUMFLEX	Circumflex
_	95	5F	137	UNDERSCORE	Underscore
`	96	60	140	GRAVE ACCENT	Grave accent
a	97	61	141	a	Lower case letter
b	98	62	142	b	Lower case letter
c	99	63	143	c	Lower case letter
d	100	64	144	d	Lower case letter
e	101	65	145	e	Lower case letter
f	102	66	146	f	Lower case letter
g	103	67	147	g	Lower case letter
h	104	68	150	h	Lower case letter
i	105	69	151	i	Lower case letter
j	106	6A	152	j	Lower case letter
k	107	6B	153	k	Lower case letter
l	108	6C	154	l	Lower case letter
m	109	6D	155	m	Lower case letter
n	110	6E	156	n	Lower case letter
o	111	6F	157	o	Lower case letter
p	112	70	160	p	Lower case letter
q	113	71	161	q	Lower case letter
r	114	72	162	r	Lower case letter
s	115	73	163	s	Lower case letter
t	116	74	164	t	Lower case letter
u	117	75	165	u	Lower case letter

ASCII	Dec.	Hex.	Oct.	Designation	Meaning
v	118	76	166	v	Lower case letter
w	119	77	167	w	Lower case letter
x	120	78	170	x	Lower case letter
y	121	79	171	y	Lower case letter
z	122	7A	172	z	Lower case letter
{	123	7B	173	OPENING BRACE	Opening brace
	124	7C	174	VERTICAL LINE	Vertical line
}	125	7D	175	CLOSING BRACE	Closing brace
~	126	7E	176	TILDE	Tilde
DEL	127	7F	177	DELETE (RUBOUT)	Delete

16.2 Code samples



1122334455

Module 0.3

Fig. 16.1: Code type: 2/5 Interleaved



135AC

Module 0.3

Fig. 16.2: Code type: Code 39



a121314a

Module 0.3

Fig. 16.3: Code type: Codabar



abcde

Module 0.3

Fig. 16.4: Code type: Code 128



leuze

Module 0.3

Fig. 16.5: Code type: EAN 128



SC 2

Fig. 16.6: Code type: UPC-A



SC 3

Fig. 16.7: Code type: EAN 8



SC 0

S

Fig. 16.8: Code type: EAN 13 add-on



DCR 100i

Fig. 16.9: Code type: Data Matrix ECC200



DCR 100i

Fig. 16.10: Code type: QR code



Test symbol

Fig. 16.11: Code type: Aztec



DCR 200i series

Fig. 16.12: Code type: PDF417

16.3 Configuration via configuration codes

The code reader can also be configured using configuration codes. The device parameters in the device are set and permanently saved after reading this code.

Configuration changes via the configuration codes are only possible by scanning the 2D configuration code.



Proceed as follows to read in a configuration code:

- ↳ Connect the code reader to the supply voltage panel.
- ↳ Hold the configuration code at the correct distance in front of the optics of the code reader.

NOTICE	
	<p>Read in configuration codes individually!</p> <p>The configuration codes can only be read in individually.</p>

Reset to factory settings

Tab. 16.1: Configuration code: reset to factory settings

2D code	Function
	Enter programming mode
	Reset to factory default
	Exit programming mode

16.4 License terms

Leuze electronic GmbH & Co. KG grants users the right to use the Ident Studio V2 software free of charge, exclusively for the purpose of commissioning DCR 100i devices. This right is granted for an indefinite period and on a non-exclusive basis.

Leuze electronic GmbH & Co. KG does not accept any liability for damage or loss of data resulting from the use of this software, particularly if this is caused by failure to observe the warning notices listed here or the safety instructions in our operating instructions.