

## Technical data sheet

### Mounting bracket

Part no.: 424439

BT-2P45

#### Contents

- Technical data
- Dimensioned drawings

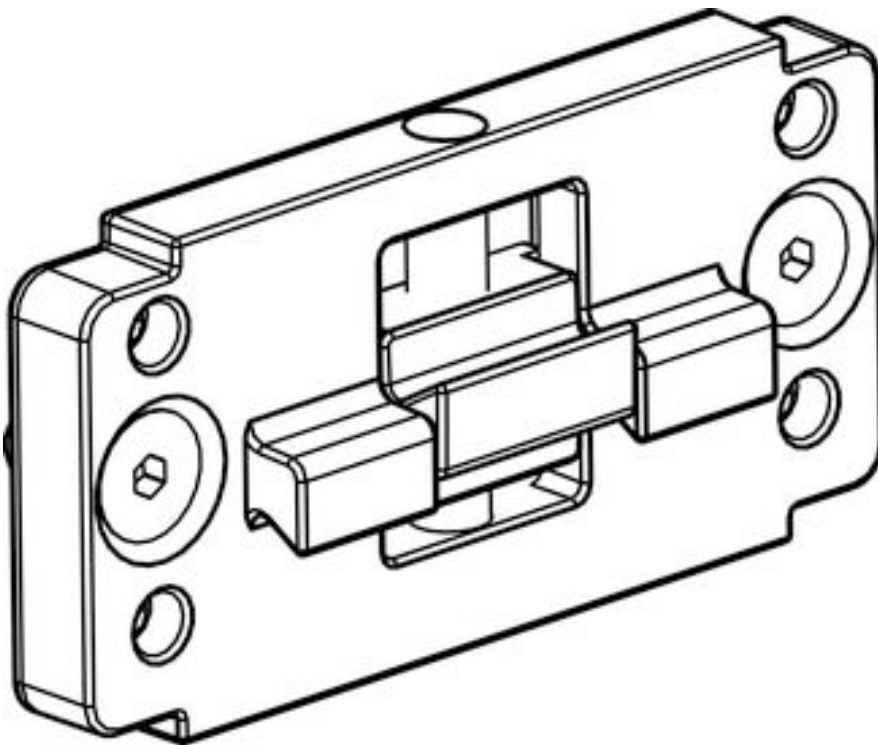

For illustration purposes only

## Technical data

### Basic data

Contains	2x BT-P45
Suitable for product group	Safety light curtains
Suitable for	ELC100 safety light curtains

### Mechanical data

Bore hole 1, diameter	M6
Bore hole 2, diameter	M6
Net weight	191 g
Design of mounting device	Mounting clamp
Type of fastening, at system	Groove mounting
Type of fastening, at device	Groove mounting
Type of mounting device	Clampable Suitable for mounting in UDC-S2, DC-S2 device columns
Mounting device material	Metal

### Classification

Customs tariff number	73182900
ECLASS 5.1.4	27279202
ECLASS 8.0	27279202
ECLASS 9.0	27273701
ECLASS 10.0	27273701
ECLASS 11.0	27273701
ECLASS 12.0	27273701
ECLASS 13.0	27273701
ECLASS 14.0	27273701
ECLASS 15.0	27273701
ECLASS 16.0	27273701
ETIM 5.0	EC002498
ETIM 6.0	EC003015
ETIM 7.0	EC003015
ETIM 8.0	EC003015
ETIM 9.0	EC003015
ETIM 10.0	EC003015
UNSPSC 26.08	31242100

## Dimensioned drawings

All dimensions in millimeters

