

Technical data sheet

Magnetically coded sensor

Part no.: 63001041

MC388-S2C5-AL-F

Contents

- Technical data
- Dimensioned drawings
- Electrical connection
- Circuit diagrams
- Operation and display
- Notes



For illustration purposes only



Technical data

Basic data

Series	MC388
--------	-------

Functions

Functions	Type 4 interlock device with low coding acc. to EN ISO 14119
-----------	--

Characteristic parameters

Mission time T_M	20 years, EN ISO 13849-1
Category	EN ISO 13849-1
$B10_d$	20,000,000 number of cycles

Electrical data

Protective circuit	Via e.g. MSI-MC311, MSI 400
Contact allocation	2NO + 1NO (signaling)
Contact type	Reed contacts (magnetically sensitive)
Requirement on the voltage supply when used acc. to cULus (UL 508)	Class 2 Circuits

Outputs

Max. switching voltage	27 V AC/DC
Switching current, max.	500 mA

Time behavior

Response time	3 ms
---------------	------

Connection

Number of connections	1 Piece(s)
-----------------------	------------

Connection 1

Function	Contact connection
Type of connection	Cable with wire-end sleeves
Cable length	5,000 mm
Sheathing material	PVC
Cable color	Gray
Number of conductors	6 -wire

Mechanical data

Design	Cubic
Dimension (W x H x L)	25 mm x 13 mm x 88 mm
Housing material	Plastic
Plastic housing	Glass fiber reinforced (PPS), self-extinguishing
Net weight	208 g
Housing color	Red
Type of fastening	Through-hole mounting
Installation position	Arbitrary, provided housing markings are aligned
Switch type	Type 4 interlock device, contactless actuation, EN ISO 14119
Approach actuation directions	3-dimensional
Mechanical life time	10,000,000 actuation cycles
External actuator	Magnetically coded
Cut-out point (OFF), min.	19 mm
Assured cut-out distance (Sar), min.	22 mm
Assured cut-in distance (Sao), max.	9 mm
Switching tolerance (without ferromagnetic materials in immediate vicinity)	-1 ... 1 mm
Distance to other magnetic sensors, min.	50 mm
Approach speed, min.	0.05 m/s

Operation and display

Number of LEDs	1 Piece(s)
----------------	------------

Environmental data

Ambient temperature, operation	-20 ... 70 °C
Degree of contamination, external	3, EN 60947-1

Certifications

Degree of protection	IP 67
Approvals	c UL US TÜV Süd (with suitable safety relay)
Test procedure for EMC in accordance with standard	EN 60947-5-3 EN 61000-6-2 EN 61000-6-3
Test procedure for oscillation in accordance with standard	EN 60947-5-3
Test procedure for shock in accordance with standard	EN 60947-5-3

Technical data

Customs tariff number	90328900
ECLASS 5.1.4	27272402
ECLASS 8.0	27272402
ECLASS 9.0	27272402
ECLASS 10.0	27272402
ECLASS 11.0	27272402
ECLASS 12.0	27274401
ECLASS 13.0	27274401
ECLASS 14.0	27274401
ECLASS 15.0	27274401
ECLASS 16.0	27274401
ETIM 5.0	EC002544
ETIM 6.0	EC002544
ETIM 7.0	EC002544
ETIM 8.0	EC002544
ETIM 9.0	EC002544
ETIM 10.0	EC002544
UNSPSC 26.08	39122205

Dimensioned drawings

All dimensions in millimeters

Dimensions of sensor and actuator

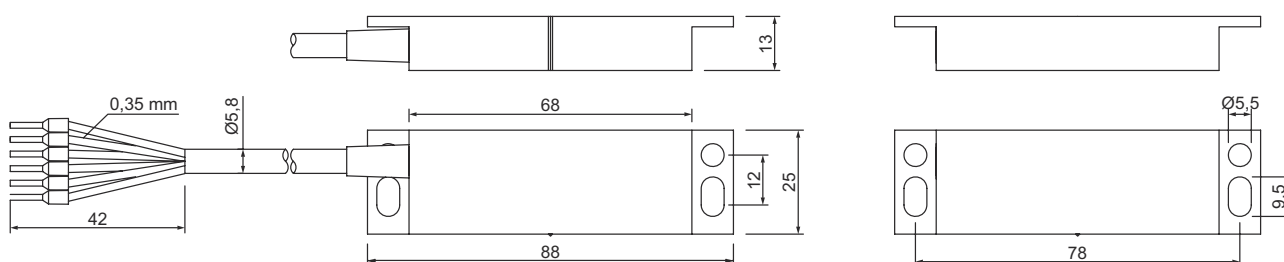

Electrical connection

Connection 1

Function	Contact connection
Type of connection	Cable with wire-end sleeves
Cable length	5,000 mm
Sheathing material	PVC
Cable color	Gray
Number of conductors	6 -wire
Assignment	Representation of contacts without activation by actuator

Conductor color

Conductor assignment

Brown	NO(1)
White	NO(1)
Blue	NO(2)
Black	NO(2)
Pink	NO(3)
Gray	NO(3)

Circuit diagrams

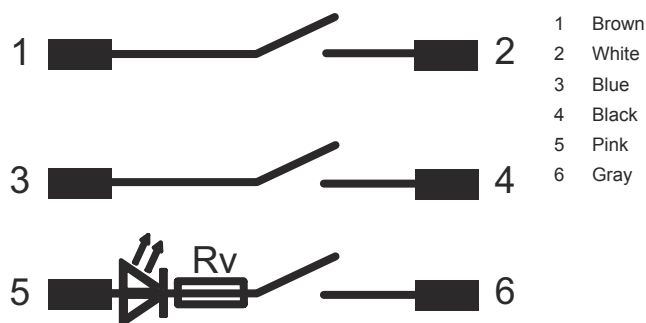

Operation and display

LED	Display	Meaning
1	Off	Safety outputs off
	Yellow, continuous light	Safety outputs active

Notes

⚠ Observe intended use!

⚠

- ☞ The product may only be put into operation by competent persons.
- ☞ Only use the product in accordance with its intended use.

ATTENTION!

i

- ☞ The sensor has no internal error detection and cannot assume a safe state in the case of failure.
- ☞ To use the sensor in accordance with DIN EN 60947-5-3, a suitable evaluation unit must be connected.
- ☞ In combination with a suitable evaluation unit, the sensor can be integrated in the control technology of safety systems up to Cat. 4 / PL e in accordance with EN ISO 13849-1 and SIL CL3 in accordance with IEC 62061.