

## Technical data sheet

### Camera

Part no.: 50132136

LCAM 408i C7F-XX

#### Contents

- Technical data
- Dimensioned drawings
- Electrical connection
- Accessories



For illustration purposes only



Ethernet

## Technical data

### Basic data

Series	LCAM
Suitable for	Use of cleaning agents
Chip	CMOS

### Functions

Software functions	Image transfer
--------------------	----------------

### Optical data

Working range	1,000 ... 5,000 mm
Camera resolution, horizontal	2,592 px
Camera resolution, vertical	1,944 px
Focal length	4 mm
Chip size	1/2.5 in
Frame rate (images per second), max.	53 pieces per second
Camera type	Color

### Electrical data

#### Performance data

Supply voltage $U_B$	18 ... 30 V, DC
Power consumption, max.	3.6 W

### Interface

Type	Ethernet
<b>Ethernet</b>	
Address assignment	DHCP Manual address assignment
Transmission speed	1 Gbit/s 10 Mbit/s 100 Mbit/s
Function	Process Service
Switch functionality	None
Transmission protocol	TCP/IP, RTP/RTSP

### Connection

#### Connection 1

Function	Configuration interface Data interface Service interface
Type of connection	Connector
Designation on device	SERVICE
Thread size	M12
No. of pins	8 -pin
Encoding	X-coded

#### Connection 2

Function	Voltage supply
Type of connection	Connector
Designation on device	PWR
Thread size	M12
No. of pins	4 -pin
Encoding	A-coded

### Mechanical data

Dimension (W x H x L)	75 mm x 55 mm x 113 mm
Housing material	Metal
Lens cover material	Glass
Net weight	411 g
Type of fastening	Dovetail grooves Mounting thread Via optional mounting device

### Environmental data

Ambient temperature, operation	-30 ... 70 °C
Ambient temperature, storage	-30 ... +70 °C

### Certifications

Degree of protection	IP 65 IP 67
----------------------	----------------

### Classification

Customs tariff number	85258900
ECLASS 5.1.4	27310101
ECLASS 8.0	27310101
ECLASS 9.0	27310201
ECLASS 10.0	27310101
ECLASS 11.0	27310101
ECLASS 12.0	27310101
ECLASS 13.0	27310101
ECLASS 14.0	27310101
ECLASS 15.0	27310101
ETIM 5.0	EC002550
ETIM 6.0	EC002550
ETIM 7.0	EC002550
ETIM 8.0	EC002550
ETIM 9.0	EC002550
ETIM 10.0	EC002550

# Dimensioned drawings

All dimensions in millimeters

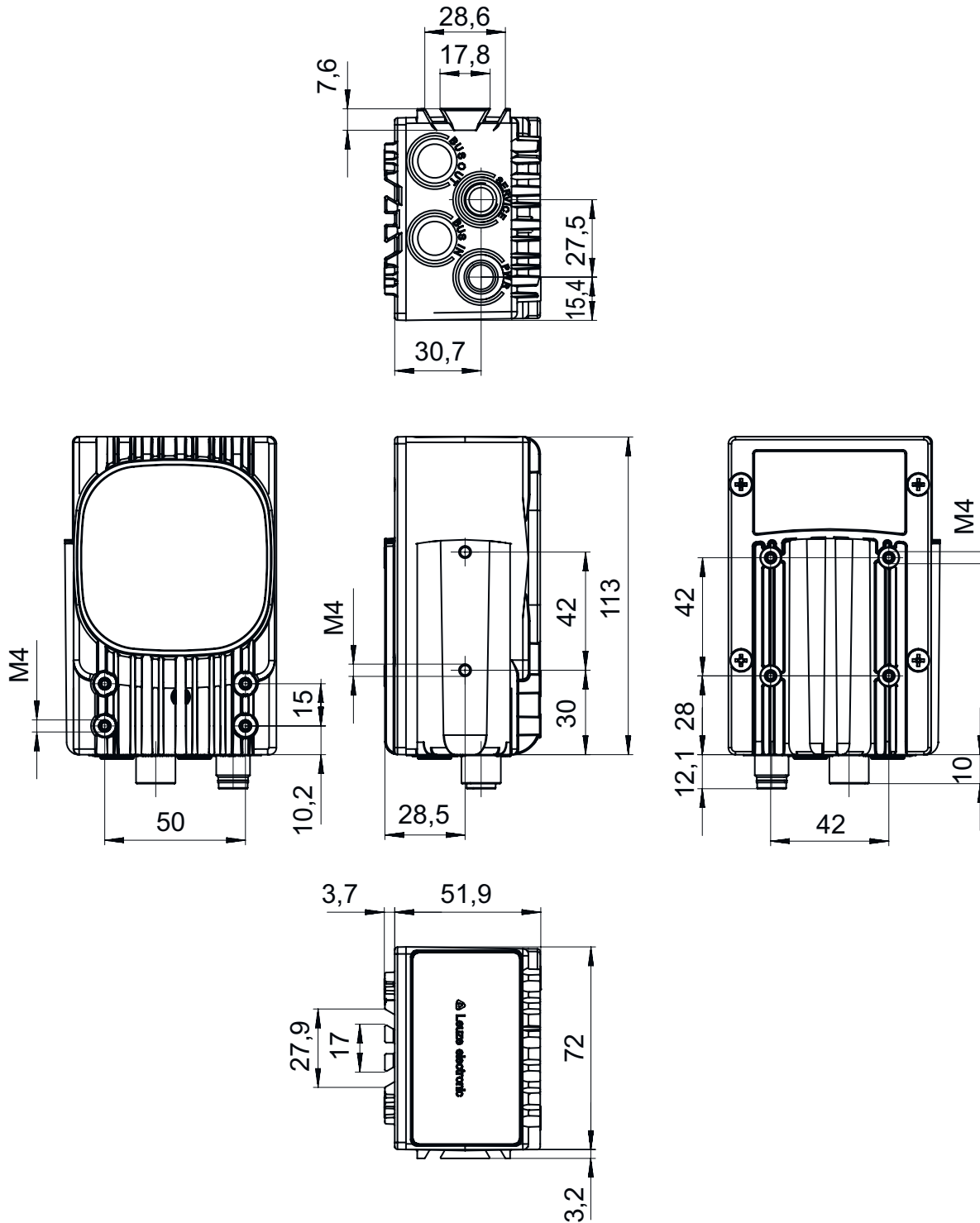

## Electrical connection

### Connection 1

### SERVICE

Function	Configuration interface Data interface Service interface
Type of connection	Connector
Thread size	M12
Type	Female
Material	Metal
No. of pins	8 -pin
Encoding	X-coded

### Pin Pin assignment

1	D1+
2	D1-
3	D2+
4	D2-
5	D4+
6	D4-
7	D3-
8	D3+

### Connection 2

### PWR

Function	Voltage supply
Type of connection	Connector
Thread size	M12
Type	Male
Material	Metal
No. of pins	4 -pin
Encoding	A-coded

### Pin Pin assignment

1	V+
2	n.c.
3	GND
4	n.c.

## Accessories

### Connection technology - Connection cables

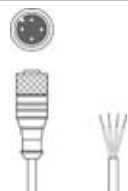
	Part no.	Designation	Article	Description
	50130657	KD U-M12-4A-P1-050	Connection cable	Connection 1: Connector, M12, Axial, Female, A-coded, 4 -pin Connector, LED: No Connection 2: Open end Shielded: No Cable length: 5.000 mm Sheathing material: PUR

## Accessories

### Connection technology - Interconnection cables

	Part no.	Designation	Article	Description
	50130743	KDS U-M12-4A-M12-4A-P1-050	Interconnection cable	Connection 1: Connector, M12, Axial, Female, A-coded, 4 -pin Connection 2: Connector, M12, Axial, Male, A-coded, 4 -pin Shielded: No Cable length: 5,000 mm Sheathing material: PUR
	50137380	KSS GB-M12-8A-RJ45-A-P7-050	Interconnection cable	Suitable for interface: Ethernet Connection 1: Connector, M12, Axial, Male, X-coded, 8 -pin Connection 2: RJ45 Shielded: Yes Cable length: 2,000 mm Sheathing material: PUR

### Connection technology - Connectors

	Part no.	Designation	Article	Description
	50137169	S GB-RJ45-8A-K-SK	Connector	Suitable for interface: Ethernet Connection: RJ45

### Mounting technology - Mounting brackets

	Part no.	Designation	Article	Description
	50121433	BT 300 W	Mounting device	Design of mounting device: Angle, L-shape Fastening, at system: Through-hole mounting Mounting bracket, at device: Screw type Type of mounting device: Adjustable Material: Metal

### Mounting technology - Rod mounts

	Part no.	Designation	Article	Description
	50027375	BT 56	Mounting device	Functions: Static applications Design of mounting device: Mounting system Fastening, at system: For 16 mm rod, For 18 mm rod, For 20 mm rod Mounting bracket, at device: Clampable Material: Metal Tightening torque of the clamping jaws: 8 N·m

#### Note



A list with all available accessories can be found on the Leuze website in the Download tab of the article detailed page.