

Technical data sheet

Mounting system

Part no.: 50152261

BTU 500M

Contents

- Technical data
- Dimensioned drawings
- Notes



For illustration purposes only

Technical data

Basic data

Suitable for	RSL 200 safety laser scanner
--------------	------------------------------

Mechanical data

Dimension (W x H x L)	112 mm x 81.2 mm x 29 mm
Net weight	398 g
Housing color	Black
Design of mounting device	Mounting system, adjustability in 2 axes
Type of fastening, at system	Through-hole mounting
Type of fastening, at device	Screw type
Swivel range	-5 ... 5 °
Mounting device material	Steel

Classification

Customs tariff number	73182900
ECLASS 5.1.4	27279202
ECLASS 8.0	27279202
ECLASS 9.0	27273701
ECLASS 10.0	27273701
ECLASS 11.0	27273701
ECLASS 12.0	27273701
ECLASS 13.0	27273701
ECLASS 14.0	27273701
ECLASS 15.0	27273701
ETIM 5.0	EC002498
ETIM 6.0	EC003015
ETIM 7.0	EC003015
ETIM 8.0	EC003015
ETIM 9.0	EC003015
ETIM 10.0	EC003015

Dimensioned drawings

All dimensions in millimeters

Mounting system BTU 500M

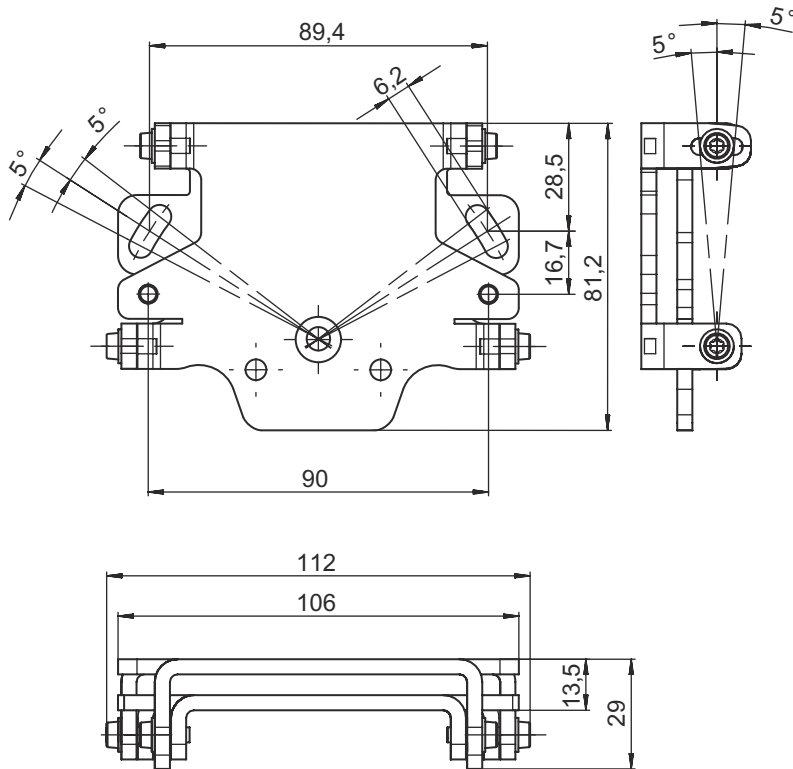

Mounting with wall mount and attachment adapter

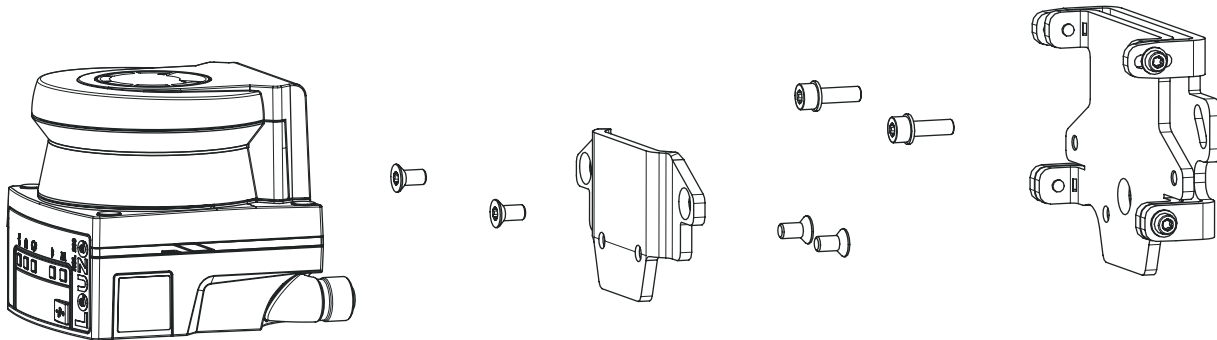

- Mount the wall mount on the system side. Two M5x16 cylinder head screws with washers are included for this purpose.
- Mount the safety sensor on the BT 500M attachment adapter using the enclosed M5x10 countersunk screws (tightening torque = 2.3 Nm).
- Mount the safety sensor (with the attachment adapter) on the BTU 500M mounting system. Fasten the countersunk head screw to 4.5 Nm.
- Align the safety sensor on the BTU 500M mounting system vertically and horizontally:
 - using the slotted holes in the wall section with the M5 cylinder head screws as well as
 - using the inclination via the slotted holes of the M4 cylinder head screws.
- After aligning the safety sensor, secure it by tightening the four M4 cylinder head screws to 3.0 Nm and the M5 cylinder head screws on the system side.

Dimensioned drawings

Mounting with wall mount and loop guard

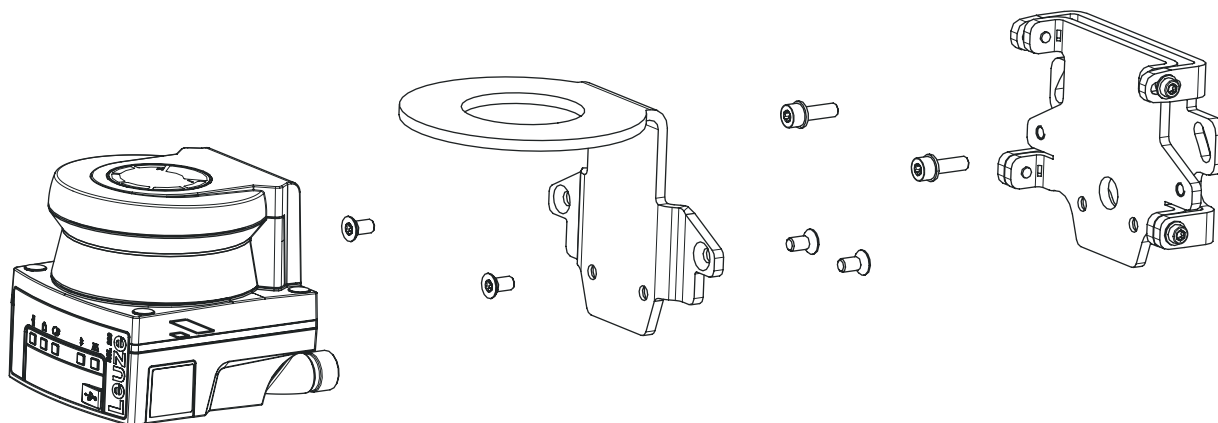

- Mount the wall mount on the system side. Two M5x16 cylinder head screws with washers are included for this purpose.
- Mount the safety sensor on the BTP 500M loop guard using the enclosed M5x10 countersunk screws (tightening torque = 2.3 Nm).
- Mount the safety sensor (with the loop guard) on the BTU 500M mounting system. Fasten the countersunk head screw to 4.5 Nm.
- Align the safety sensor on the BTU 500M mounting system vertically and horizontally:
 - using the slotted holes in the wall section with the M5 cylinder head screws as well as
 - using the inclination via the slotted holes of the M4 cylinder head screws.
- After aligning the safety sensor, secure it by tightening the four M4 cylinder head screws to 3.0 Nm and the M5 cylinder head screws on the system side.

Notes

NOTE



↳ The scanner can also be mounted directly on the mounting system without the BTP 500M loop guard or the BT 500M attachment adapter. It must be taken into account that the scanning range is limited to -135° ... +135°.