

Technical data sheet

Mounting device

Part no.: 50148152

BTC 0310M-DT

Contents

- Technical data
- Dimensioned drawings
- Accessories



For illustration purposes only

Technical data

Basic data

Suitable for product group	Industrial image processing
Suitable for	LCAM 308

Mechanical data

Design of mounting device	Mounting clamp
Type of fastening, at system	Clampable
Type of fastening, at device	Screw type
Mounting device material	Metal
Shock absorber	No

Classification

Customs tariff number	73181900
ECLASS 5.1.4	27279290
ECLASS 8.0	27279290
ECLASS 9.0	27273701
ECLASS 10.0	27273692
ECLASS 11.0	27273692
ECLASS 12.0	27273692
ECLASS 13.0	27273692
ECLASS 14.0	27273692
ETIM 5.0	EC002498
ETIM 6.0	EC003015
ETIM 7.0	EC003015
ETIM 8.0	EC003015
ETIM 9.0	EC003015

Dimensioned drawings

All dimensions in millimeters

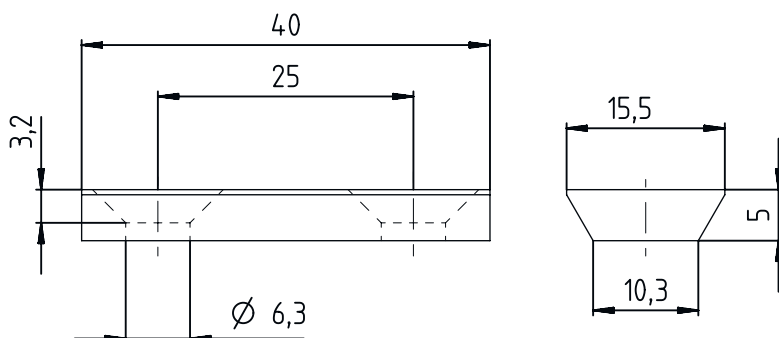



Accessories

Mounting technology - Other

	Part no.	Designation	Article	Description
	50027375	BT 56	Mounting device	Functions: Static applications Design of mounting device: Mounting system Fastening, at system: For 16 mm rod, For 18 mm rod, For 20 mm rod Mounting bracket, at device: Clampable Material: Metal Tightening torque of the clamping jaws: 8 N·m

Accessories

	Part no.	Designation	Article	Description
	50111224	BT 59	Mounting bracket	Fastening, at system: Groove mounting Mounting bracket, at device: Clampable Material: Metal Shock absorber: No
	50124941	BTU 0300M-W	Mounting device	Fastening, at system: Through-hole mounting Mounting bracket, at device: Clampable, Groove mounting, Suited for M4 screws Material: Metal Shock absorber: No

Note



A list with all available accessories can be found on the Leuze website in the Download tab of the article detailed page.