

Technical data sheet Interconnection cable

Part no.: 50133877

KDS S-M12-5A-M12-5W-V1-020

Contents

- Technical data
- Electrical connection
- Circuit diagrams

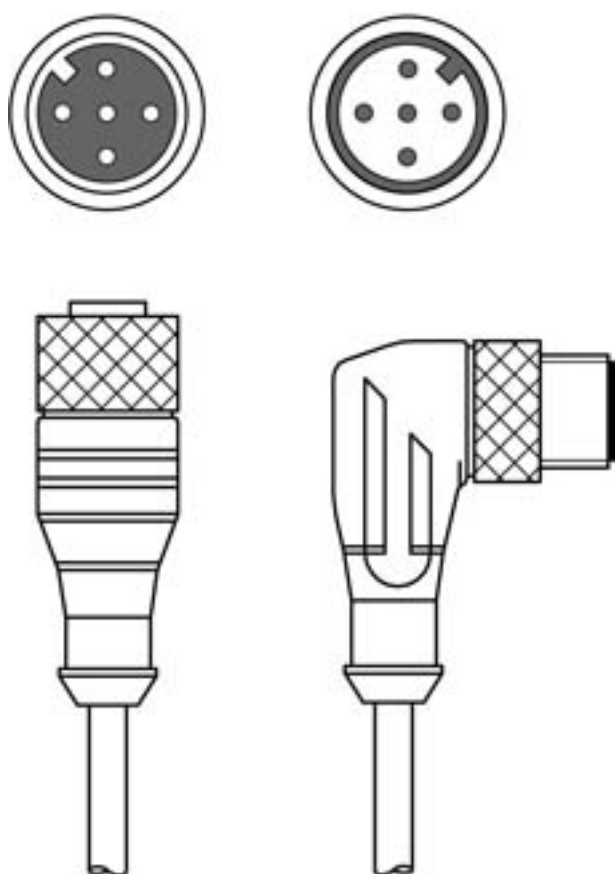

For illustration purposes only



Technical data

Basic data

Application	Chemical resistant
-------------	--------------------

Connection

Connection 1

Type of connection	Connector
Thread size	M12
Type	Female
No. of pins	5 -pin
Encoding	A-coded
Version	Axial
Connector, LED	No

Connection 2

Type of connection	Connector
Thread size	M12
Type	Male
No. of pins	5 -pin
Encoding	A-coded
Version	Angled

Cable properties

Number of conductors	5 Piece(s)
Wire cross section	0.34 mm ²
AWG	22
Sheathing color	Black
Shielded	Yes
Silicone-free	Yes
Cable design	Interconnection cable
Cable diameter (external)	5.6 mm
Cable length	2,000 mm
Sheathing material	PVC
Wire insulation	PVC
Suitability for drag chains	No
Properties of the outer sheathing	Free of CFC, cadmium, silicone and lead, easily machine-processable
Resistance of the outer sheathing	Good oil, gasoline and chemical resistance, flame retardant in accordance with UL 1581 VW1 / CSA FT1

Mechanical data

Width across flats	13 mm
Net weight	116 g
Bending radius, flexible laying, min.	Min. 10 x cable diameter
Bending radius, stationary laying, min.	Min. 10 x cable diameter

Operation and display

Environmental data

Ambient temperature, operation, flexible use	-5 ... 80 °C
Ambient temperature, operation, stationary use	-30 ... 80 °C

Certifications

Degree of protection	IP 65
	IP 67
Approvals	c UL US
UL file number	E366145

Classification

Customs tariff number	85444290
ECLASS 5.1.4	27279201
ECLASS 8.0	27279218
ECLASS 9.0	27060311
ECLASS 10.0	27060311
ECLASS 11.0	27060311
ECLASS 12.0	27060311
ECLASS 13.0	27060311
ECLASS 14.0	27060311
ECLASS 15.0	27060311
ECLASS 16.0	27060311
ETIM 5.0	EC001855
ETIM 6.0	EC001855
ETIM 7.0	EC001855
ETIM 8.0	EC001855
ETIM 9.0	EC001855
ETIM 10.0	EC001855
UNSPSC 26.08	26121604

Electrical connection

Connection 1

Type of connection	Connector
Thread size	M12
Type	Female
No. of pins	5 -pin
Encoding	A-coded
Version	Axial
Connector, LED	No

Electrical connection

Connection 2

Type of connection	Connector
Thread size	M12
Type	Male
No. of pins	5 -pin
Encoding	A-coded
Version	Angled

Circuit diagrams

