

## Technical data sheet

### Mounting device

Part no.: 50144385

BTA 0100M

#### Contents

- Technical data
- Dimensioned drawings



For illustration purposes only

## Technical data

### Basic data

Suitable for product group	Optical distance sensors
Suitable for	AMS 100i

### Mechanical data

Type of fastening, at system	Through-hole mounting
Type of fastening, at device	Screw type
Type of mounting device	Adjustable
Mounting device material	Aluminum
	Steel
Material, at system	Steel, galvanized
Material, at device	Aluminum, with powder coating

### Classification

Customs tariff number	39269097
ECLASS 5.1.4	27279202
ECLASS 8.0	27279202
ECLASS 9.0	27273701
ECLASS 10.0	27273701
ECLASS 11.0	27273701
ECLASS 12.0	27273701
ECLASS 13.0	27273701
ECLASS 14.0	27273701
ECLASS 15.0	27273701
ETIM 5.0	EC002498
ETIM 6.0	EC003015
ETIM 7.0	EC003015
ETIM 8.0	EC003015
ETIM 9.0	EC003015
ETIM 10.0	EC003015

## Dimensioned drawings

All dimensions in millimeters

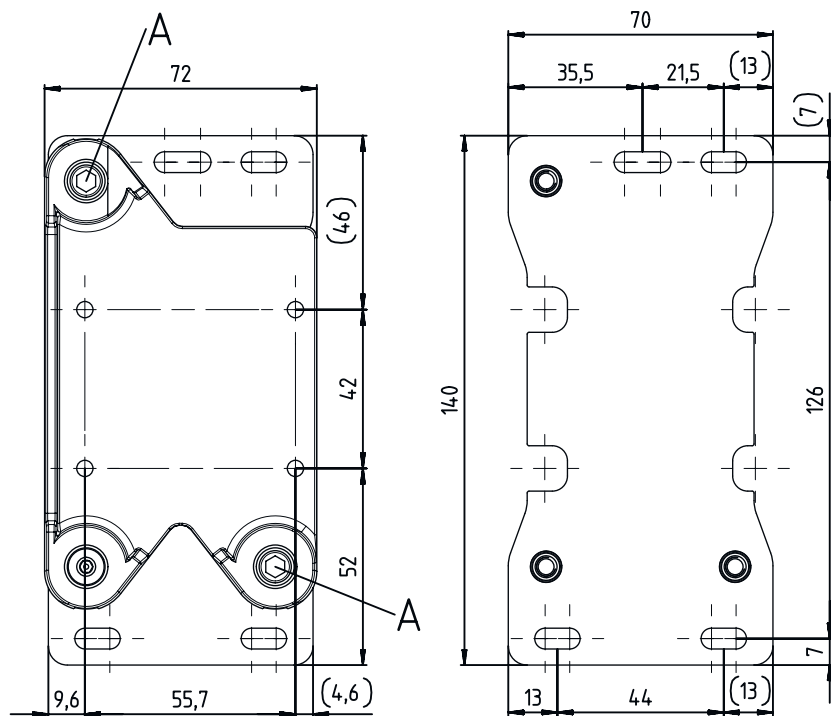

A Adjustment screws with hexagon socket WAF4