

Technical data sheet Stationary bar code reader

Part no.: 50138196

BCL 95 M2/R2



For illustration purposes only

Contents

- Technical data
- Dimensioned drawings
- Electrical connection
- Diagrams
- Operation and display
- Notes
- Accessories

CE CDRH **RS**232

UL
LISTED

UK
CA

Technical data

Basic data

Series	BCL 95
--------	--------

Functions

Functions	Alignment mode
	AutoConfig
	I/O
	LED indicator
	Multiple read / MultiScan
	Output format selectable
	Reading gate control
	Reference code comparison

Read data

Code types, readable	2/5 Interleaved
	Codabar
	Code 128
	Code 32
	Code 39
	Code 93
	EAN 128
	EAN 8/13
	EAN Addendum
	EAN/UPC
	Pharmacode (available upon consultation)
	UPC-A
	UPC-E
Scanning rate, typical	600 scans/s

Optical data

Reading distance	41 ... 186 mm
Light source	Laser, Red
Wavelength	655 nm
Laser class	1, in accordance with IEC 60825-1:2014 (EN 60825-1:2014)
Transmitted-signal shape	Continuous
Usable opening angle (reading field opening)	66 °
Modulus size	0.15 ... 0.5 mm
Reading method	Line scanner
Scanning rate	600 scans/s
Beam deflection	Via rotating polygon wheel
Light beam exit	Front

Electrical data

Protective circuit	Short circuit protected
--------------------	-------------------------

Performance data

Supply voltage U_B	4.75 ... 5.5 V, DC
Current consumption, max.	350 mA

Inputs

Number of digital switching inputs	1 Piece(s)
------------------------------------	------------

Switching inputs

Voltage type	DC
Switching voltage	5V DC

Outputs

Number of digital switching outputs	1 Piece(s)
-------------------------------------	------------

Switching outputs

Voltage type	DC
Switching voltage	5 ... 30 V DC, 20 mA

Switching output 1

Switching element	Transistor, NPN
Function	configurable

Interface

Type	RS 232
------	--------

RS 232

Function	Process
Transmission speed	4,800 ... 57,600 Bd
Data format	Adjustable
Start bit	1
Data bit	7,8
Stop bit	1.2
Parity	Adjustable
Transmission protocol	Adjustable
Data encoding	ASCII
	HEX

Service interface

Type	RS 232
------	--------

RS 232

Function	Service
----------	---------

Connection

Number of connections	1 Piece(s)
-----------------------	------------

Connection 1

Function	Data interface
	Signal IN
	Signal OUT
	Voltage supply
Type of connection	Cable
Cable length	2,000 mm
Sheathing material	PVC
Cable color	Black
Number of conductors	7 -wire
Wire cross section	0.081 mm ²

Mechanical data

Design	Cubic
Dimension (W x H x L)	62 mm x 23.8 mm x 43.5 mm
Housing material	Metal
Metal housing	Diecast zinc
Lens cover material	Glass
Net weight	210 g
Housing color	Red
	Silver
Type of fastening	Fastening thread

Operation and display

Type of display	LED
Number of LEDs	2 Piece(s)

Technical data

Environmental data

Ambient temperature, operation	5 ... 40 °C
Ambient temperature, storage	-20 ... 60 °C
Relative humidity (non-condensing)	0 ... 90 %
Extraneous light protection, max.	2,000 lx

Certifications

Degree of protection	IP 54
Protection class	III
Approvals	c UL US
Test procedure for EMC in accordance with standard	EN 61326-1:2013-01 FCC 15-CFR 47 Part 15 (09-07-2015) Limits Class B
Test procedure for shock in accordance with standard	IEC 60068-2-27, test Ea
Test procedure for vibration in accordance with standard	IEC 60068-2-6, test Fc

Classification

Customs tariff number	84719000
ECLASS 5.1.4	27280102
ECLASS 8.0	27280102
ECLASS 9.0	27280102
ECLASS 10.0	27280102
ECLASS 11.0	27280102
ECLASS 12.0	27280102
ECLASS 13.0	27280102
ECLASS 14.0	27280102
ECLASS 15.0	27280102
ECLASS 16.0	27280102
ETIM 5.0	EC002550
ETIM 6.0	EC002550
ETIM 7.0	EC002550
ETIM 8.0	EC002550
ETIM 9.0	EC002550
ETIM 10.0	EC002550
UNSPSC 26.08	43211701

Dimensioned drawings

All dimensions in millimeters

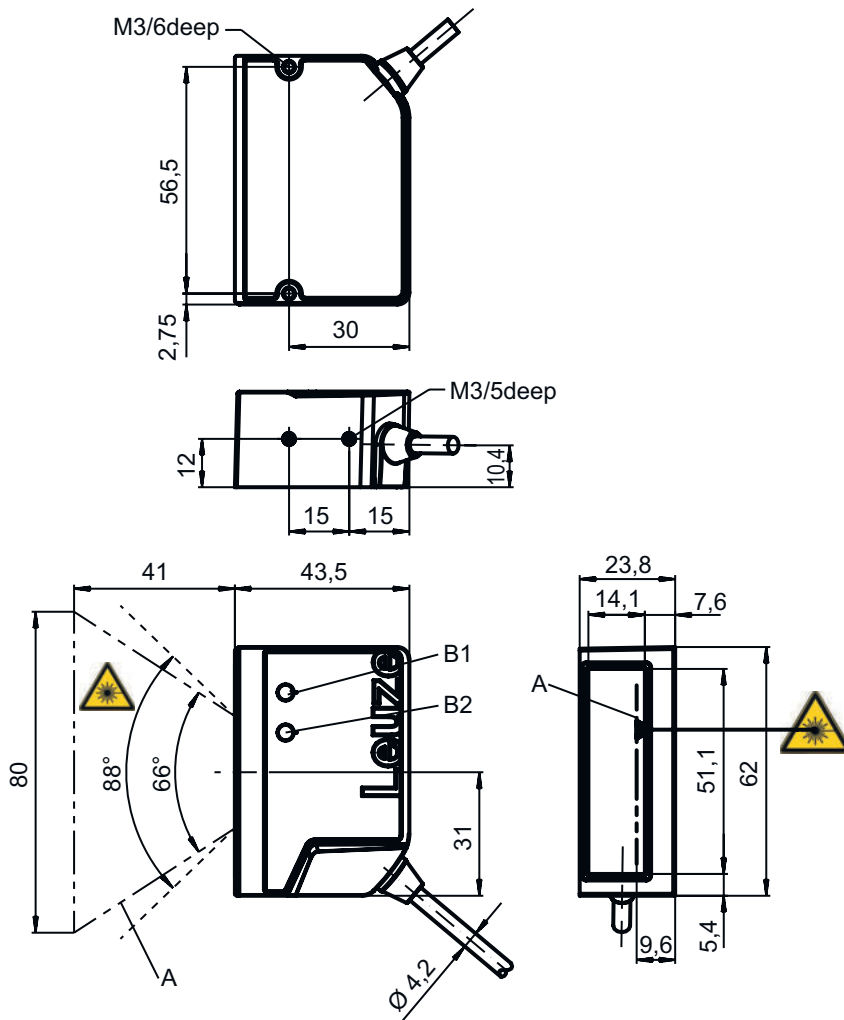

- A Laser beam
- B1 Decode LED
- B2 Status LED

NOTE For exact positioning of the laser beam in the application, the scanner must be aligned.

Electrical connection

Connection 1

Function	Data interface
	Signal IN
	Signal OUT
	Voltage supply
Type of connection	Cable
Cable length	2,000 mm
Sheathing material	PVC
Cable color	Black
Number of conductors	7 -wire
Wire cross section	0.081 mm ²

Electrical connection

Conductor color	Conductor assignment
Red	V+
Orange	IN 1
Violet	GND
Black	OUT 1
White	RS 232 RxD
Green	RS 232 TxD
Yellow	Functional earth (FE)

Diagrams

Reading field curve for module $m = 0.165 \dots 0.2 \text{ mm}$ (6.5 ... 8 mil)

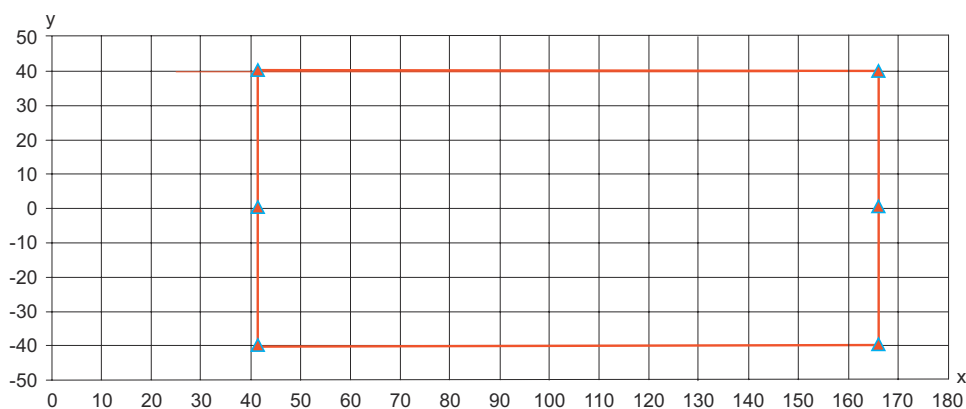

x Reading distance [mm]
 y Reading field width [mm]

Reading field curve for module $m = 0.2 \dots 0.5 \text{ mm}$ (8 ... 20 mil)

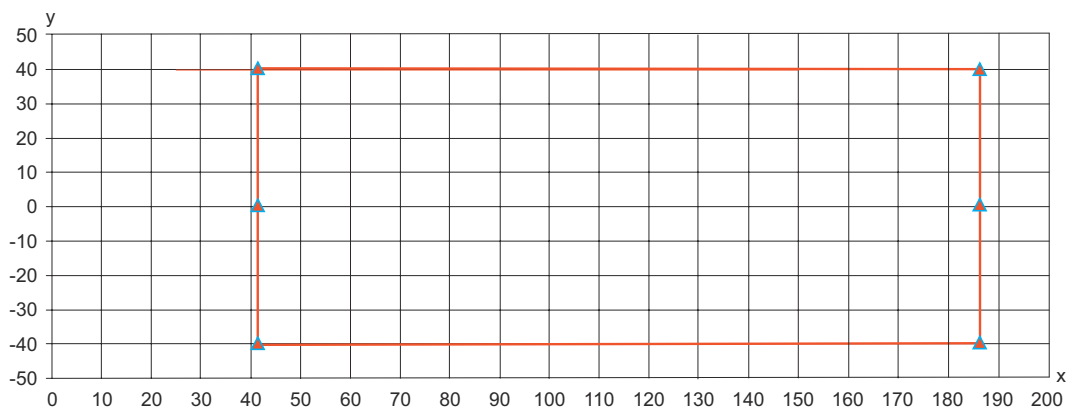

x Reading distance [mm]
 y Reading field width [mm]

Operation and display

LED	Display	Meaning
1 PWR	Green, flashing	Initialization
	Green, continuous light	Operational readiness
	Red, flashing	Warnings
	Red, continuous light	Error
	Orange, flashing	Service operation active
2 GOOD READ	Green, 200 ms on	Reading successful
	Red, 200 ms off	No reading result
	Orange, continuous light	Reading gate active

Notes

Observe intended use!

This product is not a safety sensor and is not intended as personnel protection.

The product may only be put into operation by competent persons.

Only use the product in accordance with its intended use.

For UL applications:

For UL applications, use is only permitted in Class 2 circuits in accordance with the NEC (National Electric Code).

ATTENTION! LASER RADIATION – CLASS 1 LASER PRODUCT

The device satisfies the requirements of IEC/EN 60825-1:2014 safety regulations for a product of **laser class 1**

Observe the applicable statutory and local laser protection regulations.

The device must not be tampered with and must not be changed in any way. There are no user-serviceable parts inside the device. Repairs must only be performed by Leuze electronic GmbH + Co. KG.

NOTE

Affix laser information and warning signs!
Laser information and warning signs are affixed to the device. In addition, self-adhesive laser information and warning signs (stick-on labels) are supplied in several languages.

Affix the laser information sheet to the device in the language appropriate for the place of use. When using the device in the US, use the stick-on label with the "Complies with 21 CFR 1040.10" note.

Affix the laser information and warning signs near the device if no signs are attached to the device (e.g. because the device is too small) or if the attached laser information and warning signs are concealed due to the installation position.

Affix the laser information and warning signs so that they are legible without exposing the reader to the laser radiation of the device or other optical radiation.

Notes

WARNING!



If the scanner motor fails during the emission of laser radiation, the limit value of laser class 2 in accordance with IEC 60825-1 Edition 2.0 (2007) and Edition 3.0 (2014) could be exceeded. The device has safeguards to prevent this occurrence.

- ⚡ If the emitted laser beam is at a standstill, immediately disconnect the faulty bar code reader from the voltage supply.
- ⚡ The BCL 95 emits scanned optical radiation at a wavelength of 655 nm (red). Looking at the device's mirror and operating at the lowest scanning rate (400 scans/s) at a viewing distance of 65 mm results in pulses with a pulse duration of 120 µs on the retina of the eye. The total pulse peak power at the exit window is less than 2.1 mW. The average laser power is, thus, less than 1 mW, corresponding to laser class 2 in accordance with EN 60825-1, Edition 2.0 (2007) and IEC 60825-1, Edition 2.0 (2007) and less than the limit value of 0.39 mW for laser class 1 in accordance with EN 60825-1, Edition 3.0 (2014) and IEC 60825-1, Edition 3.0 (2014).

Accessories

Mounting technology - Mounting brackets

	Part no.	Designation	Article	Description
	50118542	BT 200M.5	Mounting bracket	Design of mounting device: Angle, L-shape Fastening, at system: Through-hole mounting Mounting bracket, at device: Screw type, Suited for M3 screws Type of mounting device: Adjustable Material: Stainless steel

Mounting technology - Rod mounts

	Part no.	Designation	Article	Description
	50119331	BTU 900M-D12	Mounting system	Contains: 2x M4 x 20 screw, 2x M4 x 25 screw, 2x washers with Ø 4,3 mm each Design of mounting device: Mounting system Fastening, at system: For 12 mm rod, Sheet-metal mounting Mounting bracket, at device: Screw type Type of mounting device: Clampable, Swiveling, Turning, 360° Material: Metal

Note



⚡ A list with all available accessories can be found on the Leuze website in the Download tab of the article detailed page.