

Technical data sheet

Mounting bracket

Part no.: 540355

BT-SET-240CS-E

Contents

- Technical data
- Dimensioned drawings



Figure can vary

Technical data

Basic data

Suitable for	MLD 500, MLD 300 multiple light beam safety devices
	MLD-M002, MLD-M003 deflecting mirror

Mechanical data

Type of fastening, at system	Through-hole mounting
Type of fastening, at device	Clampable
Type of mounting device	Shock absorber
	Turning, 240°
Mounting device material	Metal
	Plastic

Classification

Customs tariff number	83024900
eCl@ss 8.0	27279202
eCl@ss 9.0	27273701
ETIM 5.0	EC003015
ETIM 6.0	EC003015

Dimensioned drawings

All dimensions in millimeters

BT-SET-240CS-E swivel mount

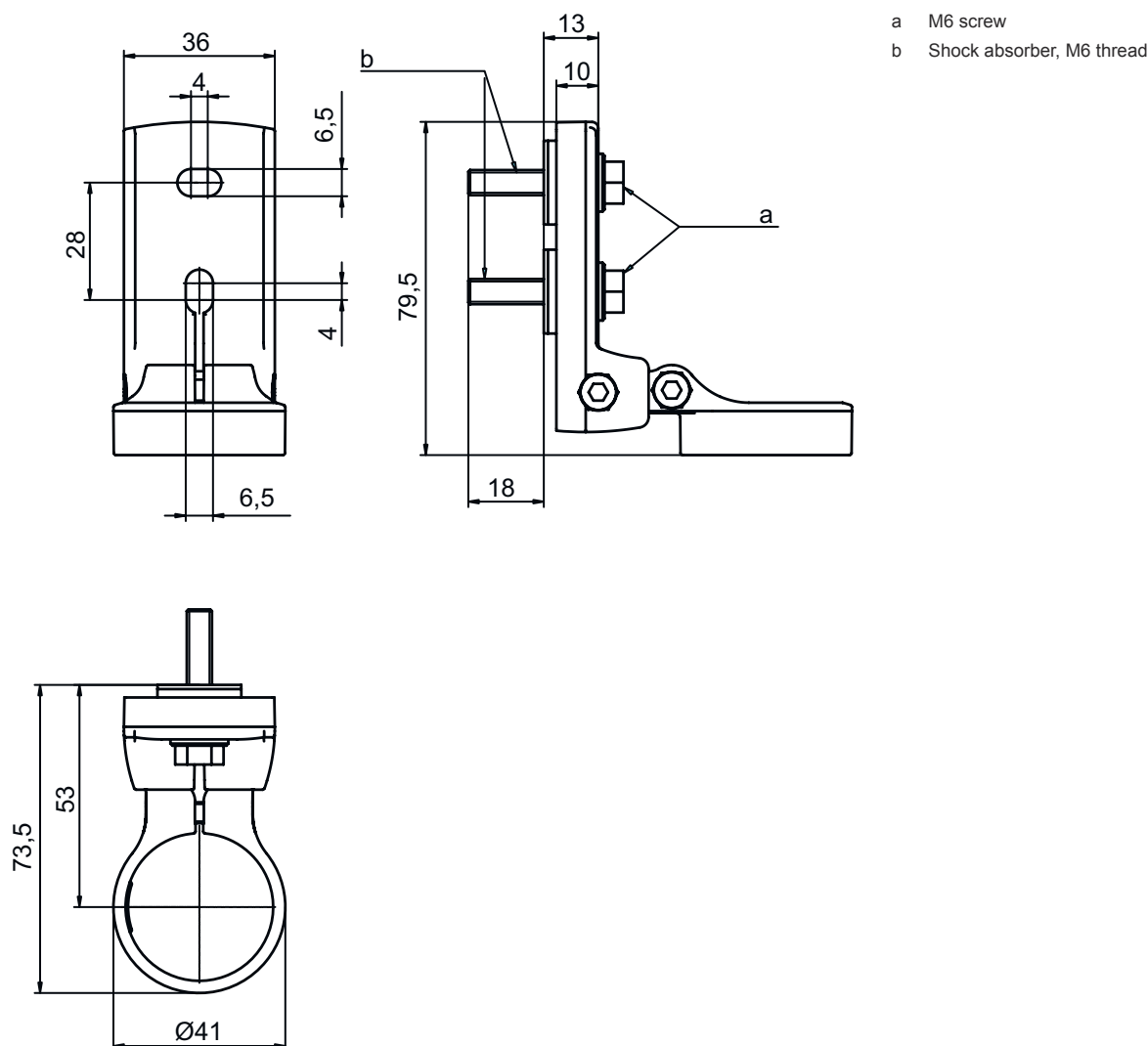

Dimensioned drawings

Mounting dimensions

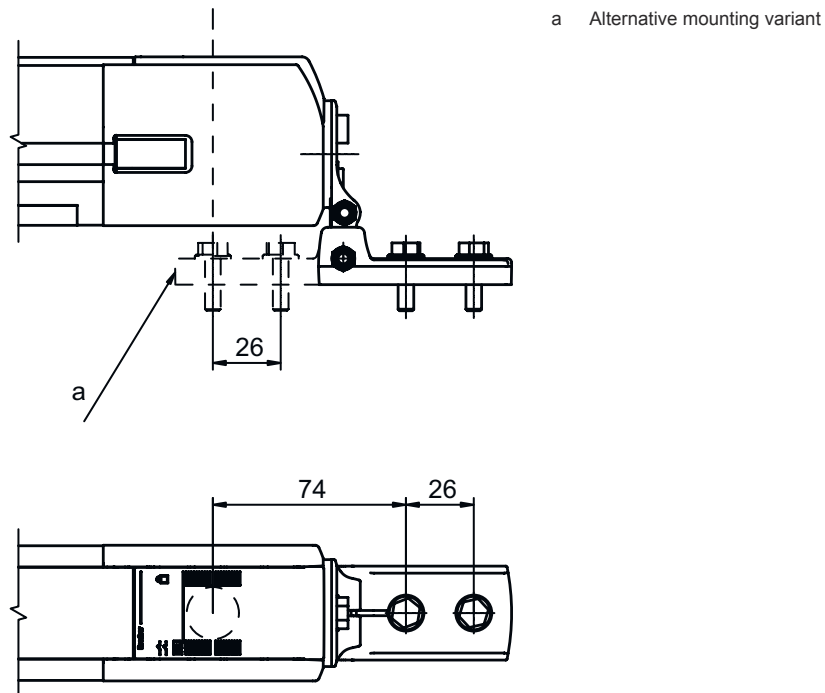

Mounting variants

