

Technical data sheet Optical distance sensor

Part no.: 50151466

ODSL 30/24-30M-Ex d

Contents

- Technical data
- Dimensioned drawings
- Electrical connection
- Notes



For illustration purposes only



CDRH



Technical data

Basic data

Series	30
Type of scanning system	Against object

Special version

Special version	Ex-protected
-----------------	--------------

Optical data

Beam path	Collimated
Light source	Laser, Red
Wavelength	655 nm
Laser class	2, IEC/EN 60825-1:2014
Transmitted-signal shape	Pulsed
Light spot size [at sensor distance]	6 mm [10,000 mm]
Type of light spot geometry	Round

Measurement data

Measurement range, additional text	The sensor has 3 switching outputs, no measurement data output
Measurement range (6 ... 90 % diffuse reflection)	200 ... 30,000 mm
Resolution	1.0 mm
Accuracy, short range	2 % (+/-) without referencing / 1 % (+/-) with referencing (with measurement range up to 2.5 m)
Accuracy, distant range	1 % (+/-) without referencing / 1 % (+/-) with referencing (with measurement range of 5 ... 30 m)
Reproducibility (3 sigma)	2 mm
Temperature drift	0 ... 0.5 mm/K
Referencing	Yes
Optical distance measurement principle	Phase measurement

Electrical data

Protective circuit	Polarity reversal protection Short circuit protected
--------------------	---

Performance data

Supply voltage U_B	18 ... 30 V, DC
Residual ripple	0 ... 15 %, From U_B
Open-circuit current	0 mA

Inputs

Number of digital switching inputs	2 Piece(s)
------------------------------------	------------

Switching inputs

Type	Digital switching input
------	-------------------------

Digital switching input 1

Assignment	Connection 1, pin 2
Function	Programmable

Digital switching input 2

Assignment	Connection 1, pin 5
Function	Programmable

Outputs

Number of digital switching outputs	3 Piece(s)
-------------------------------------	------------

Switching outputs

Type	Digital switching output
Voltage type	DC
Switching voltage	high: $\geq(U_B - 2V)$

Switching output 1

Assignment	Connection 1, pin 4
Switching element	Transistor, Push-pull

Switching output 2

Assignment	Connection 1, pin 6
Switching element	Transistor, Push-pull

Switching output 3

Assignment	Connection 1, pin 7
Switching element	Transistor, Push-pull

Time behavior

Response time	30 ... 100 ms
Readiness delay	1,000 ms

Connection

Number of connections	1 Piece(s)
-----------------------	------------

Connection 1

Function	Signal IN Signal OUT Voltage supply
Type of connection	Connector
Thread size	M12
Type	Male
Material	Plastic
No. of pins	8 -pin
Encoding	A-coded

Mechanical data

Design	Cubic
Dimension (W x H x L)	135 mm x 143 mm x 290 mm
Housing material	Metal
Metal housing	Aluminum
Lens cover material	Glass
Net weight	6,500 g
Housing color	Silver

Operation and display

Type of display	LC Display LED
Operational controls	LC Display Membrane keyboard

Environmental data

Ambient temperature, operation	-10 ... 45 °C
Ambient temperature, storage	-40 ... 70 °C

Ex specification

Ex device category	2D 2G
Ex-zone	1 21

Technical data

Certifications

Degree of protection	IP 67
Protection class	II
Standards applied	IEC 60947-5-2

Classification

Customs tariff number	90318020
ECLASS 5.1.4	27270801
ECLASS 8.0	27270801
ECLASS 9.0	27270801
ECLASS 10.0	27270801
ECLASS 11.0	27270801
ECLASS 12.0	27270916
ECLASS 13.0	27270916
ECLASS 14.0	27270916
ECLASS 15.0	27270916
ECLASS 16.0	27270916
ETIM 5.0	EC001825
ETIM 6.0	EC001825
ETIM 7.0	EC001825
ETIM 8.0	EC001825
ETIM 9.0	EC001825
ETIM 10.0	EC001825
UNSPSC 26.08	39121528

Dimensioned drawings

All dimensions in millimeters

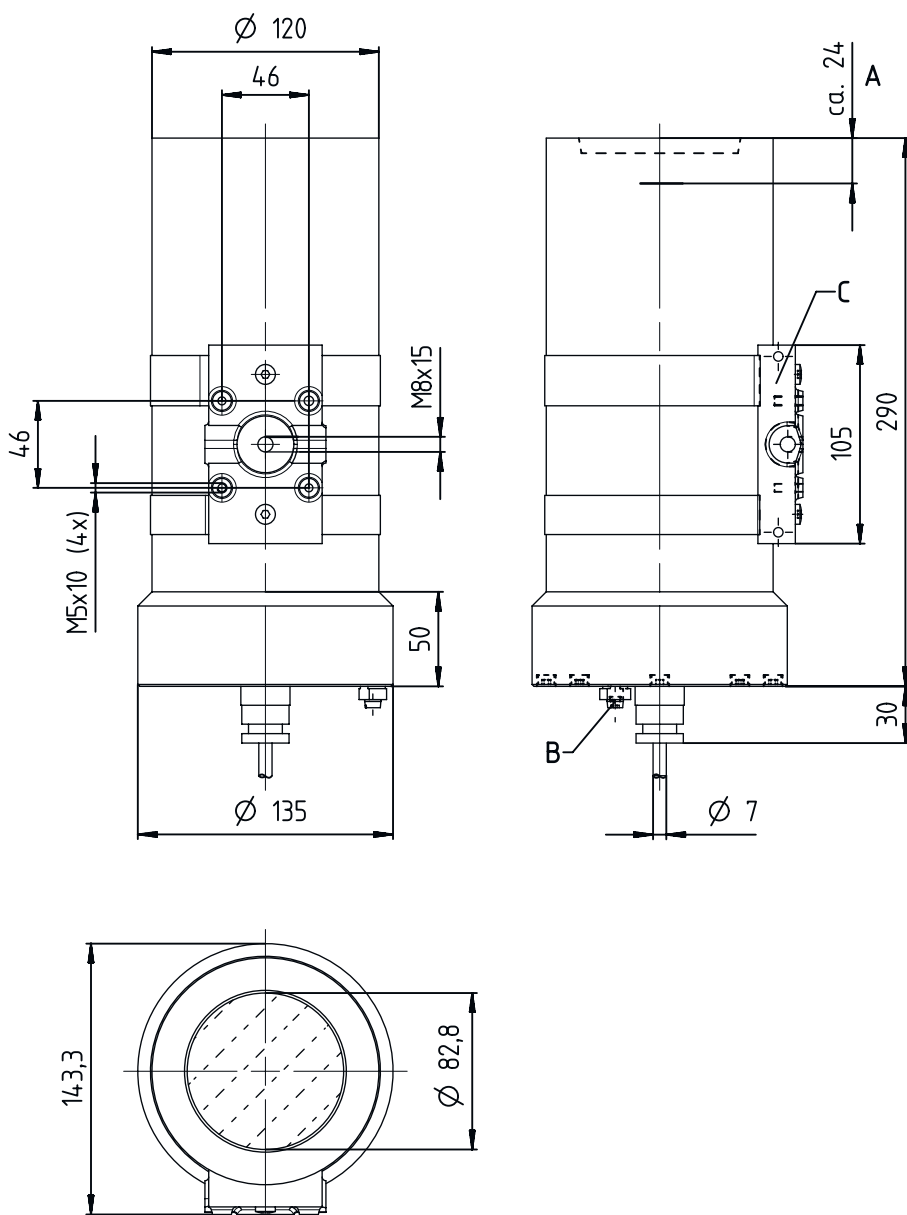

- A Reference edge for the measurement (distance zero point)
- B Earthing
- C Base mounting

Electrical connection

Connection 1

Function	Signal IN Signal OUT Voltage supply
Type of connection	Connector
Thread size	M12
Type	Male
Material	Plastic
No. of pins	8 -pin
Encoding	A-coded

Electrical connection

Pin	Pin assignment
1	+10...30 V DC
2	active/reference
3	GND
4	Q1
5	teach Q1/Q2
6	Q2
7	Q3
8	teach Q3

Notes



Observe intended use!



- ☞ This product is not a safety sensor and is not intended as personnel protection.
- ☞ The product may only be put into operation by competent persons.
- ☞ Only use the product in accordance with its intended use.



ATTENTION! LASER RADIATION – CLASS 2 LASER PRODUCT



Do not stare into beam!

The device satisfies the requirements of IEC/EN 60825-1:2014 safety regulations for a product of **laser class 2** as well as the U.S. 21 CFR 1040.10 regulations with deviations corresponding to Laser Notice No. 56 from May 08, 2019.

- ☞ Never look directly into the laser beam or in the direction of reflected laser beams! If you look into the beam path over a longer time period, there is a risk of injury to the retina.
- ☞ Do not point the laser beam of the device at persons!
- ☞ Interrupt the laser beam using a non-transparent, non-reflective object if the laser beam is accidentally directed towards a person.
- ☞ When mounting and aligning the device, avoid reflections of the laser beam off reflective surfaces!
- ☞ CAUTION! The use of operating and adjusting devices other than those specified here or the carrying out of differing procedures may lead to dangerous exposure to radiation!
- ☞ Observe the applicable statutory and local laser protection regulations.
- ☞ The device must not be tampered with and must not be changed in any way.
There are no user-serviceable parts inside the device.
Repairs must only be performed by Leuze electronic GmbH + Co. KG.

NOTE



Affix laser information and warning signs!

Laser information and warning signs are affixed to the device. In addition, self-adhesive laser information and warning signs (stick-on labels) are supplied in several languages.

- ☞ Affix the laser information sheet to the device in the language appropriate for the place of use. When using the device in the US, use the stick-on label with the "Complies with 21 CFR 1040.10" note.
- ☞ Affix the laser information and warning signs near the device if no signs are attached to the device (e.g. because the device is too small) or if the attached laser information and warning signs are concealed due to the installation position.
- ☞ Affix the laser information and warning signs so that they are legible without exposing the reader to the laser radiation of the device or other optical radiation.